

literature review of the applications of silver methanesulfonate in catalysis

Author: BenchChem Technical Support Team. **Date:** December 2025

Compound of Interest

Compound Name: Silver methanesulfonate

Cat. No.: B1581209

[Get Quote](#)

Silver Methanesulfonate in Catalysis: A Comparative Guide

For Researchers, Scientists, and Drug Development Professionals

Silver methanesulfonate (AgOMs), a versatile and efficient catalyst, has carved a niche in modern organic synthesis. Its ability to activate alkynes and promote various transformations makes it a valuable tool for constructing complex molecular architectures. This guide provides a comprehensive literature review of the applications of **silver methanesulfonate** in catalysis, offering an objective comparison with alternative catalysts supported by experimental data. Detailed methodologies for key experiments are provided to facilitate replication and further investigation.

Catalytic Performance Comparison

To provide a clear and concise overview, the following tables summarize the performance of **silver methanesulfonate** in key catalytic applications and compare it with common alternatives.

Synthesis of α,β -Unsaturated Ketones via Propargyl Alcohol Rearrangement

The Meyer-Schuster rearrangement of propargylic alcohols to α,β -unsaturated ketones is a fundamental transformation in organic synthesis. Silver salts, acting as soft Lewis acids, are effective catalysts for this reaction.

Catalyst	Substrate	Product Yield (%)	Reaction Conditions	Reference
AgOMs	1,1-diphenylprop-2-yn-1-ol	95	DBU, CO ₂ (1 atm), CH ₃ CN, rt, 2 h	
AgOTf	1,1-diphenylprop-2-yn-1-ol	92	CH ₂ Cl ₂ , rt, 1 h	[1]
AuCl(PPh ₃)/AgO Tf	1-phenylprop-2-yn-1-ol	85	CH ₂ Cl ₂ , rt, 30 min	[2]
Fe(NO ₃) ₃ ·9H ₂ O/TEMPO	1-phenylprop-2-yn-1-ol	92	O ₂ (1 atm), NaCl, Toluene, rt, 6 h	[3]

Key Findings: **Silver methanesulfonate** demonstrates excellent efficacy in the rearrangement of propargylic alcohols, often providing high yields under mild conditions. While silver triflate (AgOTf) is a commonly used and effective alternative, **silver methanesulfonate** can sometimes offer comparable or even superior performance. Gold-based catalysts can also be highly efficient, albeit at a higher cost. For a greener approach, iron-catalyzed aerobic oxidation presents a viable alternative, avoiding the use of stoichiometric oxidants.

Synthesis of Propargylamines via A³ Coupling Reaction

The A³ (Aldehyde-Alkyne-Amine) coupling reaction is a powerful one-pot method for the synthesis of propargylamines, which are important building blocks in medicinal chemistry. While copper salts are the most common catalysts for this reaction, silver salts have also been employed.

Catalyst	Aldehyde	Amine	Alkyne	Product Yield (%)	Reaction Conditions	Reference
AgOAc	Benzaldehyde	Piperidine	Phenylacetylene	91	H ₂ O, 80 °C, 6 h	[4]
CuI	Benzaldehyde	Piperidine	Phenylacetylene	95	Toluene, 110 °C, 2 h	[5]
Cu(OTf) ₂	Benzaldehyde	Piperidine	Phenylacetylene	92	Neat, 80 °C, 1 h	[6]
[CuCl(2,5-bis(2-thienyl)-1-phenylphosphole) ₂]	Benzaldehyde	Piperidine	Phenylacetylene	98	Neat, rt, 24 h	[7]
TBAI	Benzaldehyde	Piperidine	Phenylacetylene	90	CH ₃ CN, 75 °C, 4-6 h	[8]

Key Findings: While silver salts like silver acetate can catalyze the A³ coupling reaction with good yields, copper-based catalysts, particularly copper(I) iodide and copper(II) triflate, are generally more efficient and widely used.[5][6] Copper catalysts often allow for shorter reaction times and milder conditions. Metal-free alternatives, such as tetra-butyl ammonium iodide (TBAI), also provide a sustainable option for this transformation.[8]

Experimental Protocols

General Procedure for Silver Methanesulfonate-Catalyzed Rearrangement of Propargyl Alcohols

To a solution of the propargyl alcohol (1.0 mmol) in acetonitrile (5 mL) is added **silver methanesulfonate** (0.05 mmol, 5 mol%) and 1,8-diazabicyclo[5.4.0]undec-7-ene (DBU) (1.2 mmol). The reaction mixture is stirred under a balloon of carbon dioxide at room temperature for the time indicated in the corresponding literature. Upon completion, the solvent is removed

under reduced pressure, and the residue is purified by column chromatography on silica gel to afford the desired α,β -unsaturated ketone.

General Procedure for Copper(I) Iodide-Catalyzed A^3 Coupling Reaction

A mixture of the aldehyde (1.0 mmol), amine (1.2 mmol), alkyne (1.5 mmol), and copper(I) iodide (0.05 mmol, 5 mol%) in toluene (5 mL) is stirred at 110 °C in a sealed tube for the specified time. After cooling to room temperature, the reaction mixture is filtered, and the filtrate is concentrated under reduced pressure. The residue is purified by column chromatography on silica gel to give the corresponding propargylamine.[5]

Reaction Mechanisms and Workflows

To visualize the underlying processes, the following diagrams illustrate the proposed reaction mechanisms and experimental workflows.

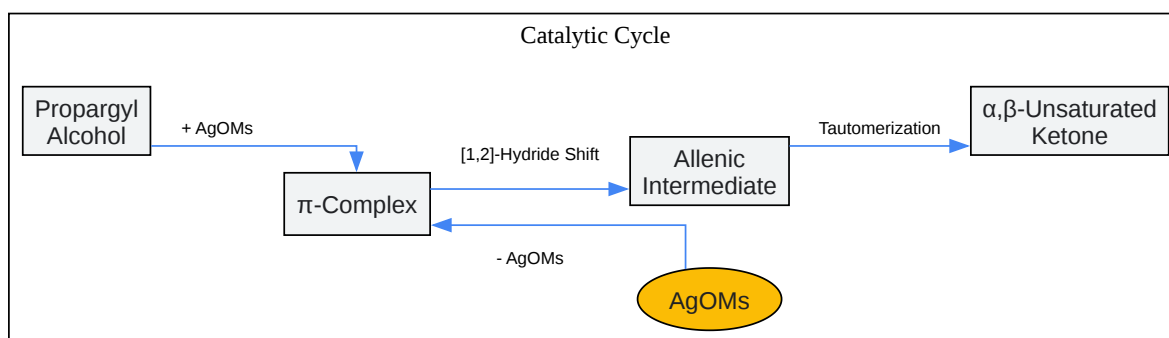

[Click to download full resolution via product page](#)

Caption: Proposed mechanism for the silver-catalyzed Meyer-Schuster rearrangement.

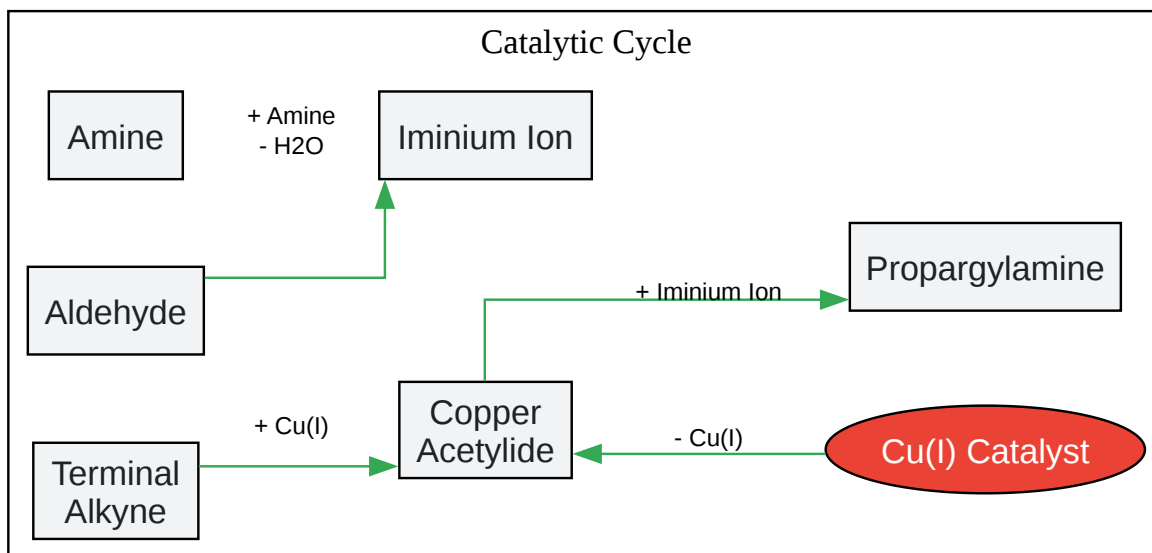

[Click to download full resolution via product page](#)

Caption: Generalized mechanism for the copper-catalyzed A³ coupling reaction.

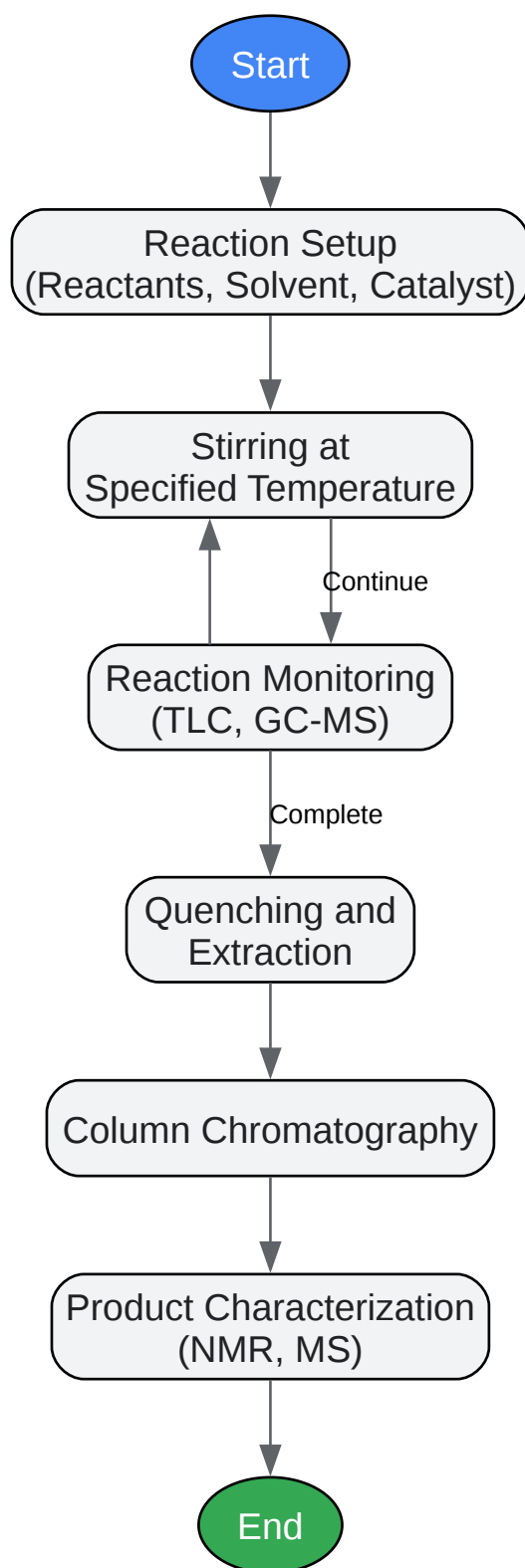

[Click to download full resolution via product page](#)

Caption: General experimental workflow for catalytic reactions.

In conclusion, **silver methanesulfonate** is a highly effective catalyst for specific organic transformations, particularly the rearrangement of propargylic alcohols. While it can be used in other reactions like the A³ coupling, alternative catalysts such as copper salts often provide superior performance. The choice of catalyst should be guided by the specific substrate, desired reaction conditions, and cost considerations. This guide provides a starting point for researchers to make informed decisions in their synthetic endeavors.

Need Custom Synthesis?

BenchChem offers custom synthesis for rare earth carbides and specific isotopic labeling.

Email: info@benchchem.com or [Request Quote Online](#).

References

- 1. Gold(III)-Catalyzed Propargylic Substitution Reaction Followed by Cycloisomerization for Synthesis of Poly-Substituted Furans from N-Tosylpropargyl Amines with 1,3-Dicarbonyl Compounds - PMC [pmc.ncbi.nlm.nih.gov]
- 2. par.nsf.gov [par.nsf.gov]
- 3. Aerobic Oxidation of Propargylic Alcohols to α,β -Unsaturated Alkynals or Alkynones Catalyzed by Fe(NO₃)₃·9H₂O, TEMPO and Sodium Chloride in Toluene [organic-chemistry.org]
- 4. Silver(I) triflate-catalyzed post-Ugi synthesis of pyrazolodiazepines - PMC [pmc.ncbi.nlm.nih.gov]
- 5. repository.fit.edu [repository.fit.edu]
- 6. Collective synthesis of acetylenic pharmaceuticals via enantioselective Nickel/Lewis acid-catalyzed propargylic alkylation - PMC [pmc.ncbi.nlm.nih.gov]
- 7. researchgate.net [researchgate.net]
- 8. researchgate.net [researchgate.net]
- To cite this document: BenchChem. [literature review of the applications of silver methanesulfonate in catalysis]. BenchChem, [2025]. [Online PDF]. Available at: [https://www.benchchem.com/product/b1581209#literature-review-of-the-applications-of-silver-methanesulfonate-in-catalysis]

Disclaimer & Data Validity:

The information provided in this document is for Research Use Only (RUO) and is strictly not intended for diagnostic or therapeutic procedures. While BenchChem strives to provide accurate protocols, we make no warranties, express or implied, regarding the fitness of this product for every specific experimental setup.

Technical Support: The protocols provided are for reference purposes. Unsure if this reagent suits your experiment? [[Contact our Ph.D. Support Team for a compatibility check](#)]

Need Industrial/Bulk Grade? [Request Custom Synthesis Quote](#)

BenchChem

Our mission is to be the trusted global source of essential and advanced chemicals, empowering scientists and researchers to drive progress in science and industry.

Contact

Address: 3281 E Guasti Rd
Ontario, CA 91761, United States
Phone: (601) 213-4426
Email: info@benchchem.com