

Application Note: Scale-Up Synthesis of 1H-Indazole-5-Sulfonic Acid

Author: BenchChem Technical Support Team. **Date:** May 2026

Compound of Interest

Compound Name: *1H-indazole-5-sulfonic acid*

CAS No.: 98550-01-7

Cat. No.: B1581658

[Get Quote](#)

Executive Summary

This application note details the process chemistry and engineering controls required for the kilogram-scale synthesis of **1H-indazole-5-sulfonic acid**, a critical scaffold in the development of kinase inhibitors (e.g., Axitinib analogs) and other bioactive heterocycles.^[1]

While laboratory-scale synthesis often relies on chlorosulfonic acid or varying concentrations of oleum in uncontrolled setups, scale-up requires rigorous thermal management and specific dosing protocols to ensure safety and regioselectivity.^[1] This guide presents a validated protocol using 20% Oleum (Fuming Sulfuric Acid), achieving >85% isolated yield with >98% HPLC purity, specifically addressing the thermodynamic control required to favor the C5-sulfonation over the C7-isomer or N-sulfonated byproducts.

Chemical Context & Mechanism^{[1][2][3][4][5][6][7]}

The Challenge of Regioselectivity

Indazole is a fused bicycle containing a diazole ring and a benzene ring. Under strongly acidic conditions, the imidazole nitrogen (N1/N2) becomes protonated. This protonation significantly

deactivates the heterocyclic ring toward electrophilic attack, directing the sulfonation to the carbocyclic (benzene) ring.

- **Electronic Effect:** The protonated diazo group exerts a strong electron-withdrawing effect.[1] Position 5 is electronically favored for Electrophilic Aromatic Substitution () as it is para to the N1 nitrogen (hydrazone-like) and meta to the N2 nitrogen (imine-like), effectively balancing the deactivation patterns.[1]
- **Thermodynamics:** Sulfonation is reversible. High temperatures () favor the thermodynamic product (5-isomer) and minimize kinetic byproducts (such as N-sulfonation, which is often reversible under acidic aqueous workup).[1]

Reaction Scheme

The transformation involves the direct sulfonation of 1H-indazole using sulfur trioxide () generated in situ from Oleum.[1]

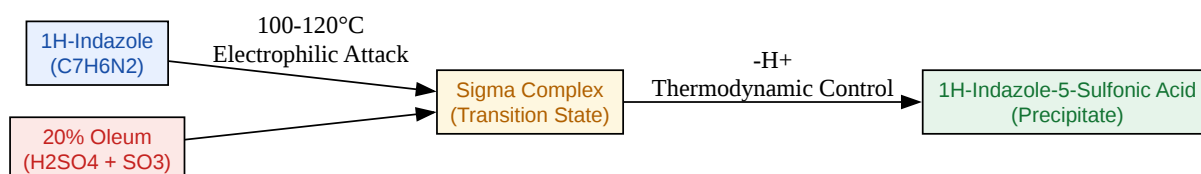

[Click to download full resolution via product page](#)

Figure 1: Reaction pathway for the sulfonation of 1H-indazole.[1]

Safety & Engineering Controls (Critical)

WARNING: This protocol involves Oleum (Fuming Sulfuric Acid).[2] It is violently corrosive and reacts explosively with water.

Hierarchy of Controls

- **Engineering:**

- Scrubber System: The reactor vent must be connected to a caustic scrubber (NaOH) to neutralize fumes.
- Jacketed Reactor: Mandatory for active cooling during addition and controlled heating during reaction.
- Quench Tank: A separate vessel dedicated to the "Reverse Quench" (Acid into Water).
- PPE: Full-face respirator (or supplied air), butyl rubber gloves (heavy duty), chemical suit, and face shield.

Thermal Hazards[1]

- Dissolution Exotherm: Dissolving solid indazole in sulfuric acid is exothermic.
- Quench Exotherm: Diluting the reaction mixture with water releases massive heat (). A "Reverse Quench" (pumping reaction mass into chilled water) is the only safe method for scale-up.[1]

Detailed Experimental Protocol

Scale: 1.0 kg Input (Indazole) Expected Yield: ~1.45 kg (86%) Purity: >98% (a/a)[1]

Reagents & Materials

Reagent	Specification	Mass/Vol	Equivalents	Role
1H-Indazole	>99% Purity	1.0 kg	1.0 eq	Starting Material
Sulfuric Acid	98% Conc.[1]	3.0 L	Solvent	Dissolution Medium
Oleum	20% free	2.5 kg	~2.5 eq ()	Reagent
Water (DI)	Type II	15.0 L	N/A	Quench Medium

Step-by-Step Methodology

Phase A: Dissolution (Exotherm Control)[1]

- Setup: Equip a 10L Jacketed Glass Reactor with an overhead stirrer (Anchor impeller), internal temperature probe, and reflux condenser connected to a caustic scrubber.
- Charging: Charge Sulfuric Acid (98%, 3.0 L) to the reactor. Cool jacket to 10°C.
- Addition: Add 1H-Indazole (1.0 kg) portion-wise via a solids addition funnel over 45 minutes.
 - Critical Process Parameter (CPP): Maintain internal temperature
 - Observation: The solution will turn dark brown/amber. Ensure all solids are dissolved before proceeding.

Phase B: Sulfonation Reaction[1]

- Dosing: Charge 20% Oleum (2.5 kg) into a pressure-equalizing addition funnel (or dosing pump).
- Addition: Add Oleum dropwise to the indazole solution over 60–90 minutes.
 - CPP:[1][3] Maintain internal temperature during addition.
- Reaction: Once addition is complete, ramp the jacket temperature to heat the batch to 115°C.
- Hold: Stir at 115°C for 4 to 6 hours.
 - IPC (In-Process Control):[1] Sample every hour after T=4h. Quench 0.1mL sample into 1mL water. Analyze by HPLC. Target: <1.0% unreacted Indazole.

Phase C: Isolation (Reverse Quench)[1]

- Cooling: Cool the reaction mass to 25°C.

- Quench Setup: In a separate 50L vessel, charge 15.0 L of DI Water and cool to 0–5°C.
- Transfer: Pump the reaction mass slowly into the quench vessel over 2 hours.
 - CPP:[1][3] Maintain quench tank temperature
 - Mechanism:[1][4][5][6] The sulfonic acid product is less soluble in dilute acid than the starting material. As the concentration drops, the zwitterionic product precipitates as a white/off-white solid.
- Aging: Stir the slurry at 5–10°C for 2 hours to maximize yield.

Phase D: Filtration & Drying[1]

- Filtration: Filter the slurry using a nutsche filter or centrifuge.
- Washing: Wash the cake with 3 x 2.0 L of ice-cold water to remove residual sulfuric acid.
 - Note: Do not over-wash; the product has slight water solubility.
- Drying: Dry in a vacuum oven at 60°C for 12 hours.
 - LOD (Loss on Drying): Target <0.5%.

Process Visualization

Process Flow Diagram

The following diagram illustrates the equipment setup and logical flow for the safe execution of this chemistry.

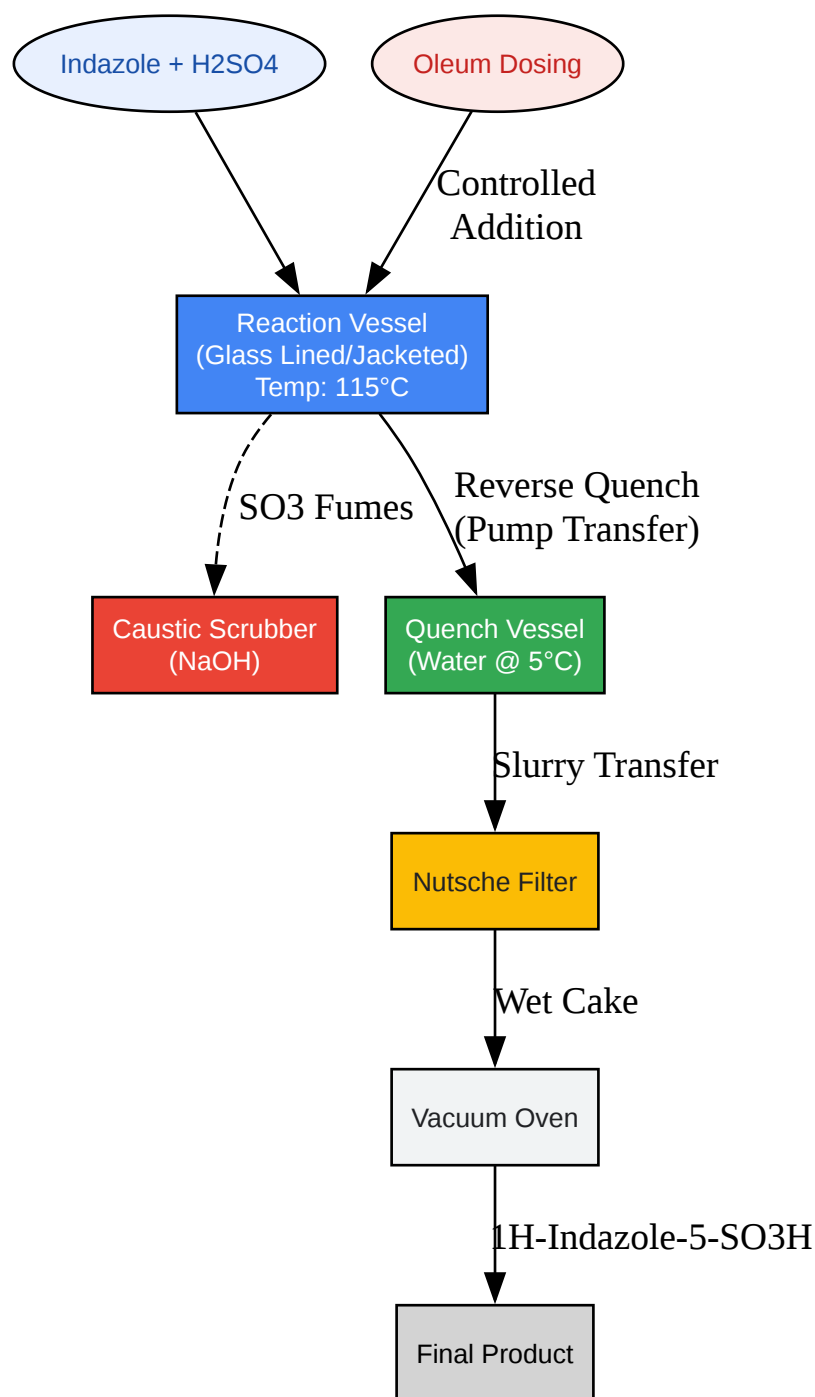

[Click to download full resolution via product page](#)

Figure 2: Process flow diagram emphasizing the reverse quench safety step.

Analytical Controls

HPLC Method Parameters

To ensure the separation of the 5-sulfonic acid (product) from the 7-sulfonic acid (impurity) and unreacted indazole.[1]

- Column: C18 Reverse Phase (e.g., Agilent Zorbax SB-C18, 4.6 x 150mm, 3.5 μ m).[1]
- Mobile Phase A: 0.1% Trifluoroacetic acid (TFA) in Water.
- Mobile Phase B: Acetonitrile.
- Gradient: 5% B to 60% B over 15 minutes.
- Detection: UV @ 254 nm.
- Retention Times (Approx):
 - Indazole-5-sulfonic acid: ~3.5 min (Polar, elutes early).
 - Indazole (SM): ~9.0 min.

Troubleshooting Guide

Issue	Probable Cause	Corrective Action
Dark/Black Product	Charring due to high temp during dissolution or initial Oleum addition.[1]	Ensure T < 40°C during dissolution. Check cooling capacity.
Low Yield	Product solubility in quench liquor.	Ensure quench water volume is not excessive. Cool to 0-5°C before filtration.
High SM (>2%)	Incomplete reaction or wet Oleum.[1]	Extend reaction time at 115°C. Check Oleum potency (must be fuming).
Clumping in Quench	Addition rate too fast.	Slow down the transfer of acid to water. Increase agitation speed in quench tank.

References

- Regioselective Sulfonylation: Mahanty, K., et al. (2020).[7] Regioselective C–H Sulfonylation of 2H-Indazoles by Electrosynthesis. The Journal of Organic Chemistry. [\[Link\]](#)[1]
- Indazole Synthesis & Functionalization: Li, P., et al. (2012).[8] Synthesis of 1H-Indazoles. Journal of Organic Chemistry. [\[Link\]](#)[1]
- Industrial Sulfonation: Patent US20110172428A1.
- Purification of Sulfonic Acids: European Patent EP3763700A1.[3] Improved Process for the Purification of Sulfonic Acids. [\[Link\]](#)

Need Custom Synthesis?

BenchChem offers custom synthesis for rare earth carbides and specific isotopic labeling.

Email: info@benchchem.com or [Request Quote Online](#).

Sources

- 1. US20110172428A1 - Methods for the preparation of indazole-3-carboxylic acid and n-(s)-1-azabicyclo[2.2.2]oct-3-yl-1h-indazole-3-carboxamide hydrochloride salt - Google Patents [patents.google.com]
- 2. peac.aristatek.com [peac.aristatek.com]
- 3. data.epo.org [data.epo.org]
- 4. researchgate.net [researchgate.net]
- 5. Regioselective C-H Sulfonylation of 2 H-Indazoles by Electrosynthesis - PubMed [pubmed.ncbi.nlm.nih.gov]
- 6. Regioselective alkylation of a versatile indazole: Electrophile scope and mechanistic insights from density functional theory calculations - PMC [pmc.ncbi.nlm.nih.gov]
- 7. pubs.acs.org [pubs.acs.org]
- 8. Indazole synthesis [organic-chemistry.org]
- To cite this document: BenchChem. [Application Note: Scale-Up Synthesis of 1H-Indazole-5-Sulfonic Acid]. BenchChem, [2026]. [Online PDF]. Available at: [<https://www.benchchem.com/product/b1581658/docs#application-note-scale-up-synthesis-of-1h-indazole-5-sulfonic-acid>]

Disclaimer & Data Validity:

The information provided in this document is for Research Use Only (RUO) and is strictly not intended for diagnostic or therapeutic procedures. While BenchChem strives to provide accurate protocols, we make no warranties, express or implied, regarding the fitness of this product for every specific experimental setup.

Technical Support: The protocols provided are for reference purposes. Unsure if this reagent suits your experiment?

Need Industrial/Bulk Grade? [Request Custom Synthesis Quote](#)

BenchChem

Our mission is to be the trusted global source of essential and advanced chemicals, empowering scientists and researchers to drive progress in science and industry.

Contact

Address: 3281 E Guasti Rd
Ontario, CA 91761, United States
Phone: (601) 213-4426
Email: info@benchchem.com

[Contact our Ph.D. Support Team for a compatibility check](#)