

An In-depth Technical Guide to the Natural Occurrence of Arabinofuranose-Containing Structures

Author: BenchChem Technical Support Team. **Date:** May 2026

Compound of Interest

Compound Name:	1,2,3,5-Tetra-O-acetyl- α -D-arabinofuranose
CAS No.:	43225-70-3
Cat. No.:	B1581442

[Get Quote](#)

Introduction to Arabinofuranose-Containing Structures

Arabinose, a five-carbon monosaccharide, is a widespread component of the cell walls of various organisms, from bacteria to plants. While it can exist in a six-membered pyranose ring form, its five-membered furanose form, arabinofuranose (Araf), is of particular biological significance. The presence of Araf residues in complex glycans imparts unique structural and functional properties that are crucial for the survival, pathogenicity, and interaction of these organisms with their environment. This guide provides a comprehensive overview of the natural occurrence of arabinofuranose-containing structures, their biosynthesis, biological roles, and the methodologies used for their study, with a focus on their relevance to researchers, scientists, and drug development professionals.

The Significance of the Furanose Conformation

The furanose configuration of arabinose introduces a higher degree of flexibility to the polysaccharide chains compared to the more rigid pyranose form. This flexibility is critical for the intricate three-dimensional structures of complex glycans, influencing their physical properties and their interactions with other molecules. The unique stereochemistry of arabinofuranosyl linkages, which are predominantly α -linked in plants and a mix of α - and β -linkages in mycobacteria, further contributes to the structural diversity and functional specificity of these molecules.

Overview of Natural Distribution and Importance

Arabinofuranose-containing structures are integral components of the cell walls of a diverse range of organisms. In bacteria, particularly in the genus *Mycobacterium*, they are essential for cell wall integrity and are key players in the host-pathogen interaction.[1][2][3] In plants, these structures are abundant in the primary and secondary cell walls, where they contribute to the structural framework and are involved in growth, development, and defense responses.[4][5][6][7] In the fungal kingdom, arabinofuranose is found as part of glycoproteins in the cell wall. The widespread occurrence and critical functions of these glycans make them important subjects of research, with significant implications for human health, agriculture, and biotechnology.

Occurrence and Structural Diversity

The structural diversity of arabinofuranose-containing glycans is vast, with variations in the backbone structure, branching patterns, and the nature of glycosidic linkages. This diversity is a reflection of the different biological roles these molecules play in different organisms.

In Bacteria: The Mycobacterial Cell Wall

The cell wall of *Mycobacterium tuberculosis*, the causative agent of tuberculosis, is a complex and unique structure that is rich in arabinofuranose-containing glycans. These molecules are essential for the viability of the bacterium and are key virulence factors.[8][9][10]

Arabinogalactan (AG)

Arabinogalactan (AG) is a major structural polysaccharide in the mycobacterial cell wall, covalently linked to peptidoglycan and esterified with mycolic acids to form the mycolyl-arabinogalactan-peptidoglycan (mAGP) complex.[3][11] This complex forms an impermeable barrier that protects the bacterium from the host immune system and antimicrobial drugs.[1][2]

The arabinan domain of AG is a highly branched structure composed of α -(1 \rightarrow 5)- and α -(1 \rightarrow 3)-linked Araf residues, with terminal β -(1 \rightarrow 2)-linked Araf residues.[12]

Lipoarabinomannan (LAM)

Lipoarabinomannan (LAM) is a large, branched lipoglycan that is anchored in the mycobacterial plasma membrane and extends to the cell surface. It plays a crucial role in modulating the host immune response. The arabinan domain of LAM is structurally similar to that of AG, with α -(1 \rightarrow 5)- and α -(1 \rightarrow 3)-linked Araf residues.

In Plants: Key Components of the Cell Wall

In plants, arabinofuranose is a key component of hemicelluloses and pectins, which are major constituents of the primary and secondary cell walls.[4]

Hemicelluloses: Arabinoxylans

Arabinoxylans are the predominant hemicelluloses in the cell walls of grasses and cereals. They consist of a linear backbone of β -(1 \rightarrow 4)-linked D-xylopyranose residues, which is substituted with α -L-arabinofuranose residues at the O-2 and/or O-3 positions.[4][13] The degree and pattern of arabinose substitution influence the physical properties of arabinoxylans, such as their solubility and viscosity, and their interactions with other cell wall components.[14]

Pectins: Arabinans and Arabinogalactans

Pectins are a complex family of polysaccharides found in the primary cell walls of all land plants. Arabinofuranose is a major constituent of two types of pectic polysaccharides: arabinans and arabinogalactans. Pectic arabinans are composed of a backbone of α -(1 \rightarrow 5)-linked L-arabinofuranose residues, which can be branched with other arabinofuranose units. Pectic arabinogalactans have a β -(1 \rightarrow 4)-galactan backbone with arabinan side chains. These pectic polysaccharides are important for cell adhesion and cell wall flexibility.[5][6][7][15][16]

In Fungi: Cell Wall Mannoproteins

In the cell walls of some fungi, arabinofuranose is found as a component of O-linked and N-linked glycans attached to mannoproteins. These arabinofuranosylated mannoproteins are involved in maintaining cell wall integrity and in the interaction of the fungus with its environment.

Biosynthesis of Arabinofuranose-Containing Polysaccharides

The biosynthesis of arabinofuranose-containing glycans is a complex process that involves the coordinated action of numerous enzymes, including glycosyltransferases that are responsible for adding arabinofuranose residues to the growing polysaccharide chain.

The Central Precursor: UDP-Arabinofuranose

The activated sugar donor for the incorporation of arabinofuranose into glycans is UDP-L-arabinofuranose (UDP-Araf). In plants, UDP-Araf is synthesized from UDP-xylose through the action of UDP-xylose 4-epimerase and UDP-arabinopyranose mutase.

Bacterial Biosynthesis: The Mycobacterial Pathway

In *Mycobacterium tuberculosis*, the biosynthesis of arabinogalactan and lipoarabinomannan involves a series of membrane-bound glycosyltransferases.^{[1][2][17]} The arabinan portion is assembled by a set of arabinofuranosyltransferases (Afts) that utilize decaprenyl-monophosphoryl-D-arabinofuranose (DPA) as the arabinose donor.^{[3][12]}

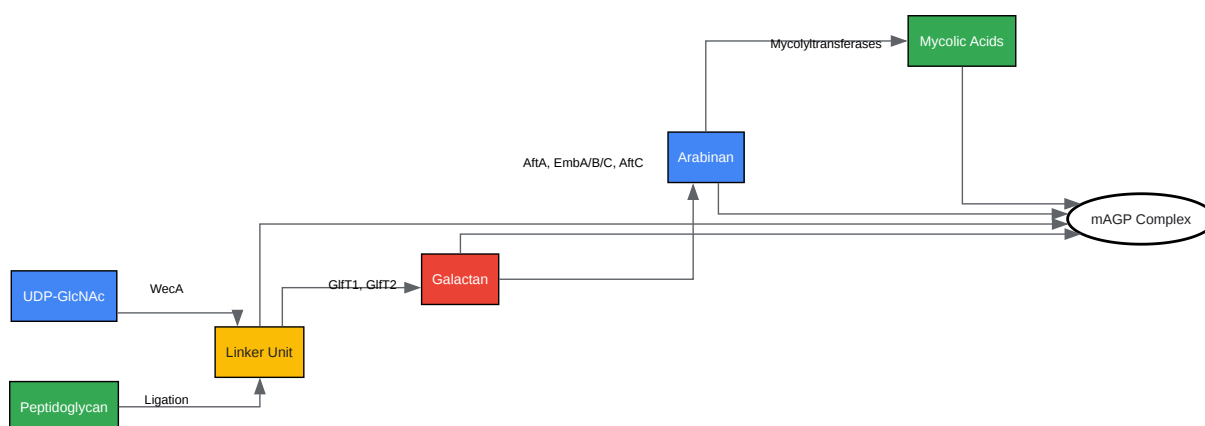

[Click to download full resolution via product page](#)

Caption: Simplified workflow of Mycobacterial Arabinogalactan Biosynthesis.

Plant Biosynthesis Pathways

The biosynthesis of arabinoxylans and pectic arabinans in plants occurs in the Golgi apparatus and involves a variety of glycosyltransferases.[13]

Arabinoxylan Synthesis

The xylan backbone of arabinoxylan is synthesized by glycosyltransferases belonging to the GT43 and GT47 families. The arabinofuranosyl side chains are added by arabinosyltransferases from the GT61 family.[4]

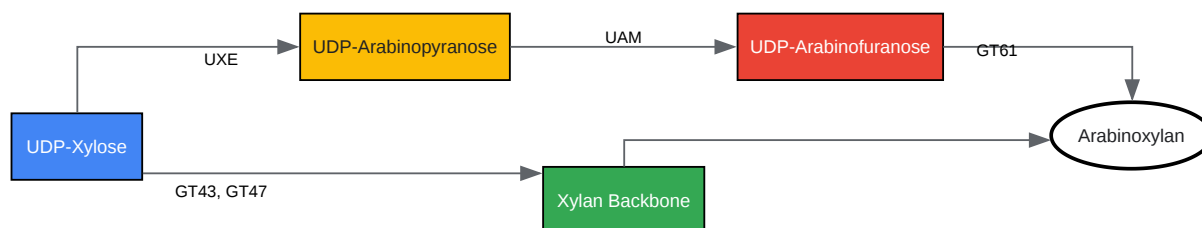

[Click to download full resolution via product page](#)

Caption: Key steps in the biosynthesis of plant arabinoxylan.

Biological Functions and Relevance to Drug Development

Arabinofuranose-containing structures have a wide array of biological functions that are critical for the organisms that produce them. These functions also make them attractive targets for the development of new drugs and therapeutics.

Roles in Bacterial Pathogenesis (Mycobacterium tuberculosis)

In *M. tuberculosis*, the arabinogalactan and lipoarabinomannan are essential for the bacterium's survival and pathogenesis. They contribute to the impermeability of the cell wall, protecting the bacterium from antibiotics and the host immune response.[\[8\]](#)[\[9\]](#)[\[10\]](#) The biosynthesis of these molecules is a key target for several anti-tuberculosis drugs, including ethambutol, which inhibits the arabinosyltransferases involved in arabinan synthesis.[\[8\]](#)[\[12\]](#)

Functions in Plant Growth, Development, and Defense

In plants, arabinofuranose-containing polysaccharides are crucial for cell wall structure and function. Pectic arabinans are essential for maintaining cell wall flexibility, particularly during processes like pollen development and in response to dehydration stress.[\[5\]](#)[\[6\]](#)[\[7\]](#)[\[15\]](#)[\[16\]](#) Arabinoxylans contribute to the mechanical strength of the cell wall and are involved in plant defense against pathogens.

Prebiotic Effects of Plant-Derived Arabinoxylans

Arabinoxylans from cereals are a major component of dietary fiber and have been shown to have significant prebiotic effects. They are fermented by beneficial bacteria in the gut, leading to the production of short-chain fatty acids that have numerous health benefits, including improved gut health and immune function.[\[18\]](#)[\[19\]](#)[\[20\]](#)[\[21\]](#)[\[22\]](#)

Arabinofuranose-Containing Structures as Drug Targets

The essential roles of arabinofuranose-containing glycans in pathogens like *M. tuberculosis* make their biosynthetic pathways attractive targets for the development of new antimicrobial drugs.[\[9\]](#)[\[10\]](#)[\[11\]](#) The unique structures of these glycans also present opportunities for the development of novel vaccines and immunotherapies.

Methodologies for Isolation, Purification, and Characterization

The study of arabinofuranose-containing structures requires specialized techniques for their extraction, purification, and structural analysis.

Extraction and Purification Protocols

The methods for extracting and purifying these complex carbohydrates vary depending on the source organism and the specific polysaccharide of interest.

Protocol for Mycobacterial Arabinogalactan

- **Cell Lysis and Delipidation:** Mycobacterium cells are harvested and subjected to mechanical lysis. The cell lysate is then treated with a series of organic solvents to remove lipids.
- **Enzymatic Digestion:** The delipidated cell wall material is treated with proteases and nucleases to remove protein and nucleic acid contaminants.
- **Alkaline Hydrolysis:** The purified cell wall material is subjected to mild alkaline hydrolysis to release the arabinogalactan from the peptidoglycan.[\[23\]](#)
- **Chromatographic Purification:** The released arabinogalactan is further purified using size-exclusion and ion-exchange chromatography.

Protocol for Plant Arabinoxylan

- **Milling and Destarching:** Cereal grains are milled to a fine powder and treated with amylases to remove starch.[\[24\]](#)
- **Alkaline Extraction:** The destarched material is extracted with an alkaline solution (e.g., sodium hydroxide or calcium hydroxide) to solubilize the arabinoxylans.[\[25\]](#)[\[26\]](#)
- **Ethanol Precipitation:** The solubilized arabinoxylans are precipitated from the alkaline extract by the addition of ethanol.[\[24\]](#)
- **Purification:** The precipitated arabinoxylan is further purified by dialysis and freeze-drying.

Protocol for Pectic Arabinan

- **Cell Wall Preparation:** Plant tissue is homogenized and washed extensively to obtain a purified cell wall fraction.
- **Chelator Extraction:** The cell walls are treated with a chelating agent (e.g., EDTA or CDTA) to solubilize the pectic polysaccharides.

- **Enzymatic Hydrolysis:** The pectin extract is treated with polygalacturonase to degrade the galacturonic acid backbone, leaving the arabinan side chains intact.
- **Chromatographic Purification:** The arabinan-rich fraction is purified using anion-exchange and size-exclusion chromatography.

Structural Analysis Techniques

A combination of spectroscopic and spectrometric techniques is used to elucidate the complex structures of arabinofuranose-containing polysaccharides.

Protocol for NMR Spectroscopic Analysis

- **Sample Preparation:** The purified polysaccharide is dissolved in deuterium oxide (D₂O).
- **1D NMR Spectroscopy:** ¹H and ¹³C NMR spectra are acquired to identify the monosaccharide composition and anomeric configurations.[\[27\]](#)[\[28\]](#)[\[29\]](#)[\[30\]](#)
- **2D NMR Spectroscopy:** A suite of 2D NMR experiments, including COSY, TOCSY, HSQC, and HMBC, are performed to establish the glycosidic linkages and branching patterns.[\[27\]](#)[\[28\]](#)[\[29\]](#)[\[30\]](#)[\[31\]](#)

Table 1: Key 2D NMR Experiments for Polysaccharide Analysis

Experiment	Information Obtained
COSY	Correlation of scalar-coupled protons within a monosaccharide residue.
TOCSY	Correlation of all protons within a spin system (monosaccharide residue).
HSQC	Correlation of protons with their directly attached carbons.
HMBC	Correlation of protons with carbons over two to three bonds, used to determine glycosidic linkages.
NOESY/ROESY	Correlation of protons that are close in space, providing information on the 3D structure and linkages.

Protocol for Mass Spectrometric Analysis

- **Sample Preparation and Derivatization:** The polysaccharide is often permethylated to improve its volatility and fragmentation behavior in the mass spectrometer.
- **MALDI-TOF MS:** Matrix-assisted laser desorption/ionization time-of-flight mass spectrometry is used to determine the molecular weight distribution of the polysaccharide.[\[32\]](#)[\[33\]](#)[\[34\]](#)[\[35\]](#)[\[36\]](#)
- **MS/MS Fragmentation:** Tandem mass spectrometry is employed to fragment the polysaccharide and obtain information about its sequence and branching.[\[32\]](#)[\[35\]](#)

Conclusion and Future Perspectives

Arabinofuranose-containing structures are a diverse and functionally important class of biomolecules. Their essential roles in the biology of bacteria and plants, coupled with their relevance to human health, make them a compelling area of ongoing research. Advances in analytical techniques, particularly NMR spectroscopy and mass spectrometry, are enabling increasingly detailed structural characterization of these complex glycans. This, in turn, is providing new insights into their biosynthesis and biological functions. For drug development

professionals, the unique biosynthetic pathways and critical roles of these molecules in pathogens present exciting opportunities for the discovery of novel therapeutic agents. The prebiotic potential of plant-derived arabinoxylans also highlights their importance in nutrition and preventative medicine. Future research will undoubtedly continue to unravel the complexities of these fascinating molecules and their myriad roles in the natural world.

References

- Alderwick, L. J., Seidel, M., Ghadbane, H., Mishra, A. K., Nigou, J., Eggeling, L., ... & Besra, G. S. (2009). Biosynthesis of mycobacterial arabinogalactan: identification of a novel $\alpha(1 \rightarrow 3)$ arabinofuranosyltransferase. *The Journal of biological chemistry*, 284(48), 33293–33301.
- Brennan, P. J. (2003).
- Crick, D. C., Mahapatra, S., & Brennan, P. J. (2001).
- Botticella, E., Sestili, F., & Lafiandra, D. (2022). Biosynthetic pathways and key enzymes for (A) arabinoxylans and (B) β -glucans.
- Solabia Nutrition. (2021, December 10).
- Caring Sunshine. (n.d.). Relationship: Gastrointestinal Tract and Arabinoxylan.
- Wu, T. H., Liu, H., Meng, X., Liu, C., Zhang, L., Wang, Q., ... & Sha, W. (2021). Sensing of mycobacterial arabinogalactan by galectin-9 exacerbates mycobacterial infection. *The EMBO journal*, 40(14), e107663.
- Marquez-Escalante, J., Carvajal-Millan, E., & Gardea-Bejar, A. A. (2018). Prebiotic effect of Arabinoxylans and Arabinoxylan-Oligosaccharides and the relationship with good health promotion.
- Broekaert, W. F., Courtin, C. M., Verbeke, K., Van de Wiele, T., Verstraete, W., & Delcour, J. A. (2011). Prebiotic and other health-related effects of cereal-derived arabinoxylans, arabinoxylan-oligosaccharides, and xylooligosaccharides. *Critical reviews in food science and nutrition*, 51(2), 178–194.
- Korduláková, J., Gilleron, M., Mikusová, K., Puzo, G., Brennan, P. J., Gicquel, B., & Jackson, M. (2002).
- Jankute, M., Cox, J. A., Harrison, J., & Besra, G. S. (2015). The Mycobacterial Cell Wall—Peptidoglycan and Arabinogalactan. *Cold Spring Harbor Perspectives in Medicine*, 5(9), a021113.
- Zhang, P., Zhang, N., Chen, Z., Wang, L., & Wang, J. (2021). Isolation, Structural, Functional, and Bioactive Properties of Cereal Arabinoxylan: A Critical Review. *Journal of Agricultural and Food Chemistry*, 69(43), 12694–12708.
- Anders, N., Wilkinson, M. D., Lovegrove, A., Freeman, J., Tryfona, T., Pellny, T. K., ... & Mitchell, R. A. (2012). Glycosyl transferases in family 61 mediate arabinofuranosyl transfer onto xylan in grasses. *Proceedings of the National Academy of Sciences*, 109(3), 989-993.

- Angala, S. K., & Jackson, M. (2014). Subfractionation and analysis of the cell envelope (lipo)polysaccharides of *Mycobacterium tuberculosis*. *Methods in molecular biology* (Clifton, N.J.), 1149, 45–60.
- Moore, J. P., Farrant, J. M., & Brandt, W. F. (2008). A role for pectin-associated arabinans in maintaining the flexibility of the plant cell wall during water deficit stress. *Plant signaling & behavior*, 3(2), 102–104.
- Anderson, A. K., & Simsek, S. (2017). Arabinoxylan extraction and purification method outline.
- The effects and benefits of arabinoxylans on human gut microbiota : a narrative review. (2020). Western Sydney University.
- Willis, J. D., Mazarei, M., Wuddineh, W. A., Sykes, R. W., Runguphan, W., & Stewart, C. N. (2016). Proposed model arabinoxylan and lignin biosynthesis pathway interactions for downregulated PvUAM1 transgenic switchgrass.
- Cankar, K., Kortstee, A., Toonen, M. A., Wolters-Arts, M., Houbein, R., Mariani, C., & Rieu, I. (2014). Pectic arabinan side chains are essential for pollen cell wall integrity during pollen development. *Plant biotechnology journal*, 12(4), 492–502.
- Moore, J. P., Farrant, J. M., & Brandt, W. F. (2008). A role for pectin-associated arabinans in maintaining the flexibility of the plant cell wall during water deficit stress.
- Azadi, P. (n.d.). Techniques. CCRC Analytical Services - UGA.
- Cankar, K., Kortstee, A., Toonen, M. A., Wolters-Arts, M., Houbein, R., Mariani, C., & Rieu, I. (2014). Pectic Arabinan Side Chains Are Essential for Pollen Cell Wall Integrity During Pollen Development. *Plant Biotechnology Journal*, 12(4), 492–502.
- Identification and expression of genes involved in the arabinoxylan biosynthetic pathway in oat. (2022). Epsilon Archive for Student Projects.
- Bhamidi, S., Scherman, M. S., & McNeil, M. R. (2009). *Mycobacterial Cell Wall Arabinogalactan: A Detailed Perspective on Structure, Biosynthesis, Functions and Drug Targeting*. Caister Academic Press.
- Porchia, A. C., & Scheller, H. V. (2000). Arabinoxylan Biosynthesis in Wheat. Characterization of Arabinosyltransferase Activity in Golgi Membranes. *Plant physiology*, 124(4), 1837–1844.
- Moore, J. P., Farrant, J. M., & Brandt, W. F. (2008). A role for pectin-associated arabinans in maintaining the flexibility of the plant cell wall during water deficit stress. Taylor & Francis Online.
- Technological and Analytical Methods for Arabinoxylan Quantification
- Cai, S., Zhang, Y., & Zhang, T. (2022). Revealing the Complexity of Polysaccharides: Advances in NMR Spectroscopy for Structural Elucidation and Functional Characterization. *Molecules* (Basel, Switzerland), 27(19), 6649.

- Wu, T. H., Liu, H., Meng, X., Liu, C., Zhang, L., Wang, Q., ... & Sha, W. (2024). Cell-autonomous targeting of arabinogalactan by host immune factors inhibits mycobacterial growth. *eLife*, 13, e92241.
- Wu, T. H., Liu, H., Meng, X., Liu, C., Zhang, L., Wang, Q., ... & Sha, W. (2024). Cell-autonomous targeting of arabinogalactan by host immune factors inhibits mycobacterial growth. *eLife*, 13, RP92241.
- Duus, J. Ø., Gotfredsen, C. H., & Bock, K. (2000). NMR spectroscopy in the study of carbohydrates: characterizing the structural complexity. *Chemical reviews*, 100(12), 4589–4614.
- Harvey, D. J. (2011). Analysis of Carbohydrates on Proteins by Offline Normal-Phase Liquid Chromatography MALDI-TOF/TOF-MS/MS.
- Daffe, M., & Draper, P. (1998). Preparation of Cell-Wall Fractions from Mycobacteria.
- Wiege, B., & Hollmann, J. (2012). ISOLATION OF ARABINOXYLANES FROM WHEAT BRAN BY ALKALINE/OXIDATIVE AND AUTOCATALYZED AQUEOUS EXTRACTION IN A SMALL TECHNICAL SCALE. *OpenAgrar*.
- Hung, C. H., & Lee, C. C. (2013). MALDI-TOF MS Analysis of Native and Permethylated or Benzimidazole-Derivatized Polysaccharides. *Semantic Scholar*.
- Wang, J., Sun, B., Cao, Y., Tian, Y., & Wang, C. (2021). Isolation, Physicochemical Properties, and Structural Characteristics of Arabinoxylan from Hull-Less Barley. *Foods (Basel, Switzerland)*, 10(5), 1109.
- Lowary, T. L. (2013). Twenty Years of Mycobacterial Glycans: Furanosides and Beyond. *Israel journal of chemistry*, 53(6-7), 469–481.
- Chen, Y. C., & Chen, C. H. (2013). MALDI-TOF MS Analysis of Native and Permethylated or Benzimidazole-Derivatized Polysaccharides. *Molecules (Basel, Switzerland)*, 18(11), 13883–13896.
- 1D & 2D and Solid-St
- Pathway for the early steps in the synthesis of the arabinogalactan... (n.d.).
- Both, P., Perlat, R., Gray, C. J., & Flitsch, S. L. (2021). Analysis of Synthetic Monodisperse Polysaccharides by Wide Mass Range Ultrahigh-Resolution MALDI Mass Spectrometry. *Analytical Chemistry*, 93(10), 4467–4473.
- NMR Spectroscopy in the Study of Carbohydrates: Characterizing the Structural Complexity. (n.d.). CIGS.
- MALDI-ToF MS analysis of immobilised carbohydrates and detection of... (n.d.).
- Ardá, A., & Jiménez-Barbero, J. (2020). Glycans in drug discovery.

Need Custom Synthesis?

BenchChem offers custom synthesis for rare earth carbides and specific isotopic labeling.

Email: info@benchchem.com or [Request Quote Online](#).

Sources

- 1. The glycosyltransferases of Mycobacterium tuberculosis - roles in the synthesis of arabinogalactan, lipoarabinomannan, and other glycoconjugates - PubMed [pubmed.ncbi.nlm.nih.gov]
- 2. academic.oup.com [academic.oup.com]
- 3. The Mycobacterial Cell Wall—Peptidoglycan and Arabinogalactan - PMC [pmc.ncbi.nlm.nih.gov]
- 4. Glycosyl transferases in family 61 mediate arabinofuranosyl transfer onto xylan in grasses - PMC [pmc.ncbi.nlm.nih.gov]
- 5. A role for pectin-associated arabinans in maintaining the flexibility of the plant cell wall during water deficit stress - PMC [pmc.ncbi.nlm.nih.gov]
- 6. researchgate.net [researchgate.net]
- 7. tandfonline.com [tandfonline.com]
- 8. Sensing of mycobacterial arabinogalactan by galectin-9 exacerbates mycobacterial infection - PMC [pmc.ncbi.nlm.nih.gov]
- 9. Cell-autonomous targeting of arabinogalactan by host immune factors inhibits mycobacterial growth | eLife [elifesciences.org]
- 10. Cell-autonomous targeting of arabinogalactan by host immune factors inhibits mycobacterial growth - PMC [pmc.ncbi.nlm.nih.gov]
- 11. Mycobacterial Cell Wall Arabinogalactan: A Detailed Perspective on Structure, Biosynthesis, Functions and Drug Targeting [caister.com]
- 12. Biosynthesis of mycobacterial arabinogalactan: identification of a novel $\alpha(1 \rightarrow 3)$ arabinofuranosyltransferase - PMC [pmc.ncbi.nlm.nih.gov]
- 13. Arabinoxylan Biosynthesis in Wheat. Characterization of Arabinosyltransferase Activity in Golgi Membranes - PMC [pmc.ncbi.nlm.nih.gov]
- 14. pubs.acs.org [pubs.acs.org]

- [15. Sci-Hub. Pectic arabinan side chains are essential for pollen cell wall integrity during pollen development / Plant Biotechnology Journal, 2014 \[sci-hub.red\]](#)
- [16. Pectic arabinan side chains are essential for pollen cell wall integrity during pollen development - PubMed \[pubmed.ncbi.nlm.nih.gov\]](#)
- [17. academic.oup.com \[academic.oup.com\]](#)
- [18. What are the health benefits of wheat arabinoxylans? - Solabia Nutrition \[solabianutrition.com\]](#)
- [19. caringsunshine.com \[caringsunshine.com\]](#)
- [20. Prebiotic effect of Arabinoxylans and Arabinoxylan-Oligosaccharides and the relationship with good health promotion \[scielo.org.mx\]](#)
- [21. Prebiotic and other health-related effects of cereal-derived arabinoxylans, arabinoxylan-oligosaccharides, and xylooligosaccharides - PubMed \[pubmed.ncbi.nlm.nih.gov\]](#)
- [22. researchers.westernsydney.edu.au \[researchers.westernsydney.edu.au\]](#)
- [23. Subfractionation and analysis of the cell envelope \(lipo\)polysaccharides of Mycobacterium tuberculosis - PMC \[pmc.ncbi.nlm.nih.gov\]](#)
- [24. Isolation, Physicochemical Properties, and Structural Characteristics of Arabinoxylan from Hull-Less Barley - PMC \[pmc.ncbi.nlm.nih.gov\]](#)
- [25. researchgate.net \[researchgate.net\]](#)
- [26. openagrar.de \[openagrar.de\]](#)
- [27. ast.uga.edu \[ast.uga.edu\]](#)
- [28. orbit.dtu.dk \[orbit.dtu.dk\]](#)
- [29. semanticscholar.org \[semanticscholar.org\]](#)
- [30. cigs.unimo.it \[cigs.unimo.it\]](#)
- [31. mdpi.com \[mdpi.com\]](#)
- [32. Analysis of Carbohydrates on Proteins by Offline Normal-Phase Liquid Chromatography MALDI-TOF/TOF-MS/MS | Springer Nature Experiments \[experiments.springernature.com\]](#)
- [33. semanticscholar.org \[semanticscholar.org\]](#)
- [34. mdpi.com \[mdpi.com\]](#)
- [35. pubs.acs.org \[pubs.acs.org\]](#)
- [36. researchgate.net \[researchgate.net\]](#)

- To cite this document: BenchChem. [An In-depth Technical Guide to the Natural Occurrence of Arabinofuranose-Containing Structures]. BenchChem, [2026]. [Online PDF]. Available at: [<https://www.benchchem.com/product/b1581442/docs#an-in-depth-technical-guide-to-the-natural-occurrence-of-arabinofuranose-containing-structures>]

Disclaimer & Data Validity:

The information provided in this document is for Research Use Only (RUO) and is strictly not intended for diagnostic or therapeutic procedures. While BenchChem strives to provide accurate protocols, we make no warranties, express or implied, regarding the fitness of this product for every specific experimental setup.

Technical Support: The protocols provided are for reference purposes. Unsure if this reagent suits your experiment?

Need Industrial/Bulk Grade? [Request Custom Synthesis Quote](#)

BenchChem

Our mission is to be the trusted global source of essential and advanced chemicals, empowering scientists and researchers to drive progress in science and industry.

Contact

Address: 3281 E Guasti Rd
Ontario, CA 91761, United States
Phone: (601) 213-4426
Email: info@benchchem.com

[Contact our Ph.D. Support Team for a compatibility check](#)