

Technical Support Center: Optimizing Reaction Conditions for 2,2-Dimethylthiirane

Author: BenchChem Technical Support Team. **Date:** May 2026

Compound of Interest

Compound Name: 2,2-Dimethylthiirane

CAS No.: 3772-13-2

Cat. No.: B1580642

[Get Quote](#)

Welcome to the technical support center for **2,2-Dimethylthiirane**. This guide is designed for researchers, scientists, and drug development professionals to provide expert advice and troubleshoot common issues encountered during its use in chemical synthesis. Our goal is to move beyond simple procedural steps and offer a deeper understanding of the causality behind experimental choices, ensuring both success and safety in the laboratory.

Frequently Asked Questions (FAQs)

Here we address some of the most common initial questions regarding the handling and reactivity of **2,2-Dimethylthiirane**.

Q1: What are the primary safety precautions I should take when working with **2,2-Dimethylthiirane**?

A1: **2,2-Dimethylthiirane** is a highly flammable liquid and vapor and can be harmful if swallowed or comes into contact with skin.^{[1][2][3]} It is crucial to handle this compound in a well-ventilated fume hood, wearing appropriate personal protective equipment (PPE), including flame-retardant gloves, safety goggles, and a lab coat.^{[1][4][5]} All ignition sources should be

eliminated from the work area, and equipment should be properly grounded to prevent static discharge.^{[1][5]}

Q2: How should I properly store **2,2-Dimethylthiirane**?

A2: Store **2,2-Dimethylthiirane** in a tightly closed container in a cool, dry, and well-ventilated area, away from heat, sparks, and open flames.^{[1][5]} It is recommended to store it under an inert atmosphere (e.g., argon or nitrogen) to prevent potential degradation. The storage temperature should be kept low, with some suppliers recommending -10°C.

Q3: What are the most common reactions involving **2,2-Dimethylthiirane**?

A3: The most prevalent reactions are nucleophilic ring-opening reactions. Due to the inherent ring strain of the three-membered thiirane ring, it is susceptible to attack by a wide range of nucleophiles.^{[6][7]} This reaction is a versatile method for introducing a thiol functionality into a molecule.

Q4: I am observing low to no reactivity in my ring-opening reaction. What are the likely causes?

A4: Several factors can contribute to low reactivity. These include:

- **Weak Nucleophile:** The nucleophilicity of the attacking species is paramount. Weakly nucleophilic reagents may not be potent enough to open the thiirane ring efficiently.
- **Steric Hindrance:** While the tertiary carbons of **2,2-Dimethylthiirane** are reactive, a sterically bulky nucleophile may have difficulty accessing the electrophilic carbon atoms.
- **Inappropriate Solvent:** The choice of solvent can significantly impact the reaction rate by affecting the solubility of reactants and stabilizing transition states.
- **Low Temperature:** While controlling temperature is crucial to prevent side reactions, excessively low temperatures can significantly slow down the desired reaction rate.

Troubleshooting Guide: Ring-Opening Reactions

This section provides a more in-depth look at specific problems you might encounter during the nucleophilic ring-opening of **2,2-Dimethylthiirane** and offers targeted solutions.

Problem 1: Low Yield of the Desired Regioisomer

Possible Cause: In unsymmetrically substituted thiiranes, the nucleophile can attack either carbon atom of the ring. With **2,2-Dimethylthiirane**, the attack typically occurs at the less substituted carbon (C-3) via an S_N2 mechanism.[6] However, under certain conditions, particularly with acidic catalysts or protic solvents, a carbocation-like intermediate can form, leading to a loss of regioselectivity.

Suggested Solutions:

- **Choice of Catalyst:** To favor the S_N2 pathway and ensure high regioselectivity, use a basic catalyst like triethylamine or a sodium-exchanged zeolite.[6] These catalysts enhance the nucleophilicity of the attacking species without promoting carbocation formation.
- **Solvent Selection:** Employ polar aprotic solvents such as THF, DMF, or acetonitrile. These solvents can help to dissolve the nucleophile and stabilize the transition state of the S_N2 reaction without protonating the thiirane sulfur, which could induce carbocation formation.
- **Nucleophile Choice:** Use a strong, non-basic nucleophile. This will favor a direct S_N2 attack over elimination or rearrangement pathways.[8]

Table 1: Effect of Catalyst and Solvent on Regioselectivity

Catalyst/Solvent System	Predominant Mechanism	Expected Outcome
Et ₃ N in MeOH	S_N2	High yield of the C-3 ring-opened product[6]
Na ⁺ -zeolite X in MeOH	S_N2 -like	High yield of the C-3 ring-opened product[6]
H ₂ SO ₄ in Benzene	S_N1 -like	Potential for a mixture of regioisomers

Experimental Protocol: Regioselective Ring-Opening with a Thiol

- In a flame-dried round-bottom flask under an inert atmosphere, dissolve **2,2-Dimethylthiirane** (1.0 eq) and the desired thiol (1.1 eq) in anhydrous methanol.

- Add triethylamine (1.2 eq) to the solution at room temperature.
- Stir the reaction mixture and monitor its progress using Thin-Layer Chromatography (TLC) or Gas Chromatography-Mass Spectrometry (GC-MS).
- Upon completion, quench the reaction with a saturated aqueous solution of ammonium chloride.
- Extract the product with a suitable organic solvent (e.g., ethyl acetate).
- Dry the organic layer over anhydrous sodium sulfate, filter, and concentrate under reduced pressure.
- Purify the crude product by flash column chromatography on silica gel.

DOT Script for Regioselective Ring-Opening

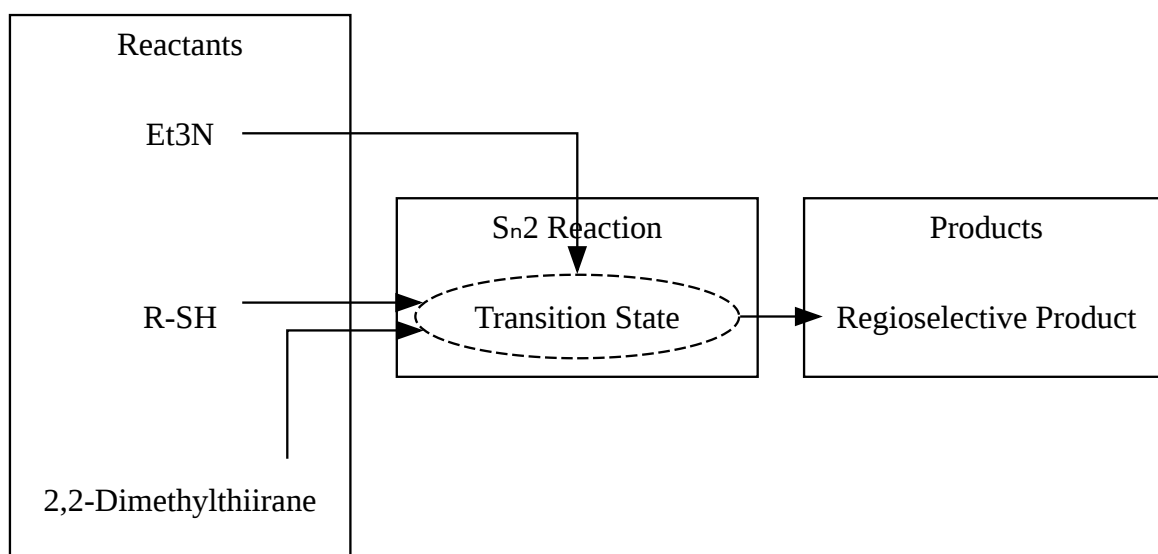

[Click to download full resolution via product page](#)

Caption: S_n2 pathway for regioselective ring-opening.

Problem 2: Competing Polymerization

Possible Cause: Thiiranes, including **2,2-Dimethylthiirane**, can undergo ring-opening polymerization, especially in the presence of cationic or anionic initiators.[9][10] Trace impurities such as acids or water can sometimes initiate this unwanted side reaction, leading to a viscous reaction mixture and low yields of the desired monomeric product.

Suggested Solutions:

- Purification of Reagents and Solvents: Ensure that all reactants and solvents are anhydrous and free of acidic or basic impurities.[11] Distillation of solvents over an appropriate drying agent is recommended.
- Control of Stoichiometry: Use a slight excess of the nucleophile to ensure that all the **2,2-Dimethylthiirane** reacts in the desired manner.
- Temperature Control: Running the reaction at a controlled, and often lower, temperature can help to minimize polymerization, which may have a higher activation energy than the desired nucleophilic attack.
- Use of Inhibitors: In some cases, the addition of a radical inhibitor can prevent unwanted side reactions, although this is less common for ionic polymerizations.

DOT Script for Competing Pathways

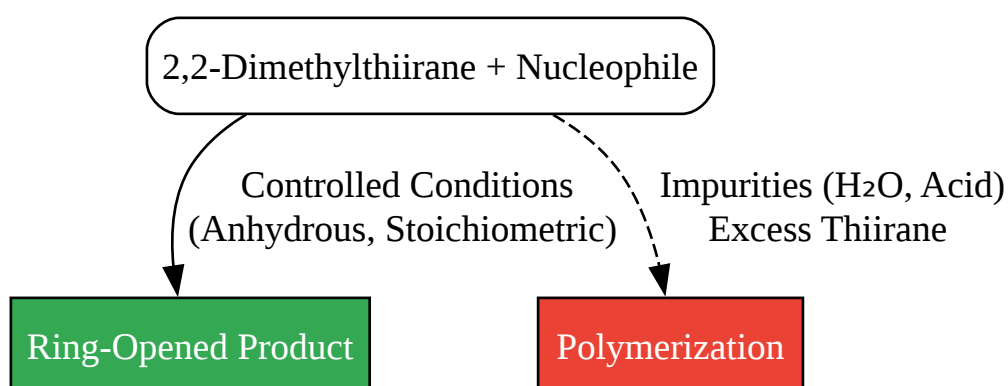

[Click to download full resolution via product page](#)

Caption: Reaction pathways for **2,2-Dimethylthiirane**.

Problem 3: Desulfurization to the Alkene

Possible Cause: Desulfurization of thiiranes to form the corresponding alkene can occur, particularly in the presence of certain reagents like phosphines or under thermal stress.^[12] While less common with nucleophilic ring-opening, it can be a competing pathway if the reaction conditions are not optimized.

Suggested Solutions:

- **Avoid High Temperatures:** Maintain the reaction at the lowest temperature that allows for a reasonable reaction rate to minimize thermal decomposition and desulfurization.
- **Choice of Reagents:** Be mindful of the reagents used. For instance, if a phosphine-based reagent is used in a subsequent step, ensure the thiirane has been fully consumed or removed to prevent unintended desulfurization.
- **Inert Atmosphere:** Conducting the reaction under an inert atmosphere can help prevent oxidation of the sulfur atom, which can sometimes lead to desulfurization pathways.

References

- Journal of the Chemical Society, Perkin Transactions 2. Novel SN2 ring-opening reactions of 2- and 2,2-substituted thiiranes with thiols using Na⁺-exchanged X-type zeolite or triethylamine in methanol. RSC Publishing.
- Fisher Scientific.
- Material Safety D
- Sigma-Aldrich.
- 2 - Safety D
- Benchchem.
- 3 - • Safety D
- PMC. Synthesis and Evaluation of Novel 2,2-Dimethylthiochromanones as Anti-Leishmanial Agents. NIH.
- Benchchem. Troubleshooting common side reactions in thiourea synthesis.
- PubChem. **2,2-Dimethylthiirane**. NIH.
- Sigma-Aldrich. **2,2-dimethylthiirane**.
- The Journal of Organic Chemistry.
- Benchchem. Technical Support Center: Purification of Crude 2,2-Dimethyl-4-oxopentanenitrile.
- University of Rochester, Department of Chemistry. How To: Troubleshoot a Reaction.
- YouTube. 3 Member Heterocycles Chemical Reactivity of Thiirane (Lecture 2).

- PMC.
- Alkyl Halides and Nucleophilic Substitution.
- PubChem. 2,3-Dimethylthiirane. NIH.
- Benchchem.
- Benchchem.
- PMC.
- DASH (Harvard).
- MDPI. Epoxide Syntheses and Ring-Opening Reactions in Drug Development.
- Nucleophilic substitution and elimin
- Chapter 2: General Methods for preparing Polymers.
- Stereoselective nucleophilic substitution reaction
- Organic Syntheses Procedure.
- ResearchGate. Main reactions of epoxidation and oxirane ring-opening process. R" and R".
- Dalton Transactions (RSC Publishing).
- ResearchGate.
- PubChem. 2,2-Dimethylbutane.
- Organic Syntheses Procedure. α -(N,N-DIMETHYLAMINO)PHENYLACETONITRILE.
- Wikipedia. 2,2-Dimethylbutane.
- Chapter 2: General Methods for preparing Polymers.
- ResearchGate. Synthesis of Dimethyl 2-(2Alkyl1,3-diaryl-3-oxopropyl)
- Organic Syntheses Procedure. (R)-3-AMINO-3-(p-METHOXYPHENYL)PROPIONIC ACID.
- (PDF)

Need Custom Synthesis?

BenchChem offers custom synthesis for rare earth carbides and specific isotopic labeling.

Email: info@benchchem.com or [Request Quote Online](#).

Sources

- [1. fishersci.com](https://fishersci.com) [fishersci.com]
- [2. sigmaaldrich.com](https://sigmaaldrich.com) [sigmaaldrich.com]
- [3. 2,2-Dimethylthiirane | C4H8S | CID 138050 - PubChem](https://pubchem.ncbi.nlm.nih.gov) [pubchem.ncbi.nlm.nih.gov]
- [4. images.thdstatic.com](https://images.thdstatic.com) [images.thdstatic.com]
- [5. fishersci.com](https://fishersci.com) [fishersci.com]

- [6. Novel SN2 ring-opening reactions of 2- and 2,2-substituted thiiranes with thiols using Na+-exchanged X-type zeolite or triethylamine in methanol - Journal of the Chemical Society, Perkin Transactions 2 \(RSC Publishing\) \[pubs.rsc.org\]](#)
- [7. youtube.com \[youtube.com\]](#)
- [8. pdf.benchchem.com \[pdf.benchchem.com\]](#)
- [9. faculty.ksu.edu.sa \[faculty.ksu.edu.sa\]](#)
- [10. researchgate.net \[researchgate.net\]](#)
- [11. pdf.benchchem.com \[pdf.benchchem.com\]](#)
- [12. pubs.acs.org \[pubs.acs.org\]](#)
- To cite this document: BenchChem. [Technical Support Center: Optimizing Reaction Conditions for 2,2-Dimethylthiirane]. BenchChem, [2026]. [Online PDF]. Available at: [\[https://www.benchchem.com/product/b1580642/docs#technical-support-center-optimizing-reaction-conditions-for-2-2-dimethylthiirane\]](https://www.benchchem.com/product/b1580642/docs#technical-support-center-optimizing-reaction-conditions-for-2-2-dimethylthiirane)

Disclaimer & Data Validity:

The information provided in this document is for Research Use Only (RUO) and is strictly not intended for diagnostic or therapeutic procedures. While BenchChem strives to provide accurate protocols, we make no warranties, express or implied, regarding the fitness of this product for every specific experimental setup.

Technical Support: The protocols provided are for reference purposes. Unsure if this reagent suits your experiment?

Need Industrial/Bulk Grade? [Request Custom Synthesis Quote](#)

BenchChem

Our mission is to be the trusted global source of essential and advanced chemicals, empowering scientists and researchers to drive progress in science and industry.

Contact

Address: 3281 E Guasti Rd
Ontario, CA 91761, United States
Phone: (601) 213-4426
Email: info@benchchem.com

Contact our Ph.D. Support Team for a compatibility check