

Technical Guide: Strategic Implementation of Double-Labeled Fmoc-Alanine in Peptide Synthesis

Author: BenchChem Technical Support Team. **Date:** May 2026

Compound of Interest

Compound Name: L-ALANINE-N-FMOC (13C3,15N)

Cat. No.: B1580352

[Get Quote](#)

Executive Summary

This technical guide analyzes the utility of Fmoc-Alanine-OH (

)—a high-fidelity isotopic probe—in modern drug discovery and structural biology. Unlike standard amino acids, this double-labeled variant serves as a dual-modal tool, enabling Absolute Quantification (AQUA) in mass spectrometry and Residue-Specific Assignment in NMR spectroscopy. This guide provides optimized protocols for Solid Phase Peptide Synthesis (SPPS) designed to maximize coupling efficiency while minimizing the consumption of this high-value reagent.

Part 1: The Isotopic Advantage in Structural Biology (NMR)

The Physics of Spectral Editing

In biomolecular NMR, the primary challenge is spectral crowding. By incorporating Fmoc-Ala (

) at specific positions, researchers utilize Residue-Specific Labeling. This technique acts as a spectral filter, rendering only the labeled Alanine residues visible in heteronuclear experiments, thereby dramatically simplifying the assignment process for large complexes (>50 kDa).

Mechanistic Utility in Pulse Sequences

The uniform labeling of the Alanine spin system (

) enables uninterrupted magnetization transfer.

Experiment	Pathway	Structural Insight
HNCA		Connects the amide proton to its own alpha carbon.
HN(CO)CA		Links the amide to the preceding residue's alpha carbon (via the carbonyl).
HCCH-TOCSY		Correlates side-chain protons; critical for Alanine's methyl group dynamics.

Diagram: Magnetization Transfer Logic

The following diagram illustrates how magnetization is transferred through the double-labeled Alanine residue during a standard triple-resonance experiment.

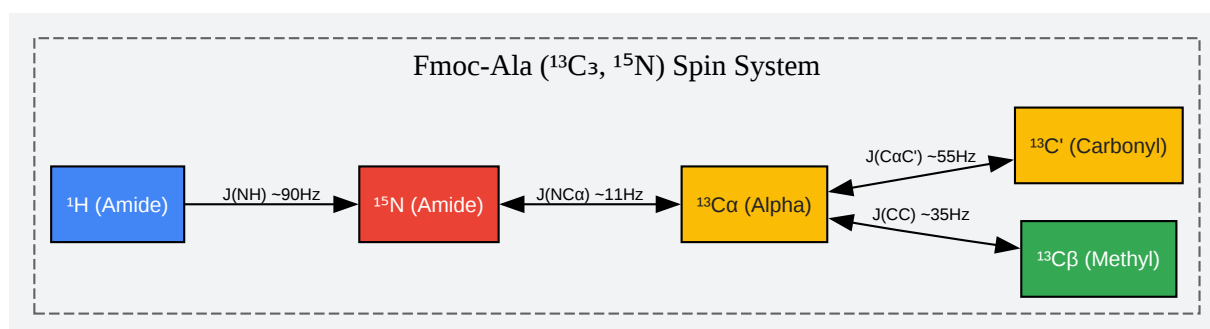

[Click to download full resolution via product page](#)

Caption: Magnetization transfer pathways enabled by contiguous

and

labeling in Alanine.

Part 2: Quantitative Precision in Proteomics (MS)

The AQUA Methodology

Fmoc-Ala (

) is the cornerstone of the AQUA (Absolute QUAntification) strategy. By synthesizing a "heavy" peptide identical to a target biomarker, researchers create an internal standard that behaves chemically identically to the analyte but is spectrally distinct.

Mass Shift Calculation

The incorporation of one double-labeled Alanine introduces a precise mass offset, shifting the peptide's m/z ratio to a noise-free region of the spectrum.

- Carbon-13 (^{13}C): 3 atoms
(+1.003 Da)
+3 Da
- Nitrogen-15 (^{15}N): 1 atom
(+0.997 Da)
+1 Da
- Total Shift: +4.0 Da per Alanine residue

Note: For tryptic peptides, which often contain multiple Alanines, the shift is additive (

Da), further separating the standard from the native peptide.

Part 3: Optimized SPPS Protocol for High-Value Reagents

The "Zero-Waste" Coupling Strategy

Because labeled Fmoc-Ala is significantly more expensive than standard reagents, the synthesis protocol must shift from "excess-driven" (standard 5-10 eq) to "efficiency-driven" (1.2-2.0 eq).

Critical Reagents:

- Coupling Agent: HATU or COMU (preferred over HBTU/DIC for expensive monomers due to faster kinetics).
- Base: DIPEA (Diisopropylethylamine) or TMP (2,4,6-Trimethylpyridine) to minimize racemization.

Step-by-Step Protocol

Step	Operation	Reagent/Condition	Duration	Notes
1	Resin Swelling	DMF / DCM (1:1)	30 min	Ensure full solvation of bead matrix.
2	Deprotection	20% Piperidine in DMF	2 x 5 min	Remove Fmoc from previous residue. Wash 5x DMF.
3	Activation	Labeled Fmoc-Ala (1.5 eq) + HATU (1.45 eq) + DIPEA (3.0 eq)	Pre-activate 30 sec	Critical: Dissolve labeled AA in min. volume of DMF (0.2 M).
4	Coupling	Add activated mix to resin	45 - 60 min	Agitate gently. Do not vortex vigorously.
5	Monitoring	Kaiser Test / Chloranil Test	5 min	If positive (blue), perform 2nd coupling with unlabeled Ala (capping) or re-couple labeled.
6	Capping	Acetic Anhydride / Pyridine	5 min	Terminates unreacted chains to prevent deletion sequences.

Workflow Diagram: Synthesis to Application

The following flowchart outlines the lifecycle of the labeled peptide from synthesis to data acquisition.

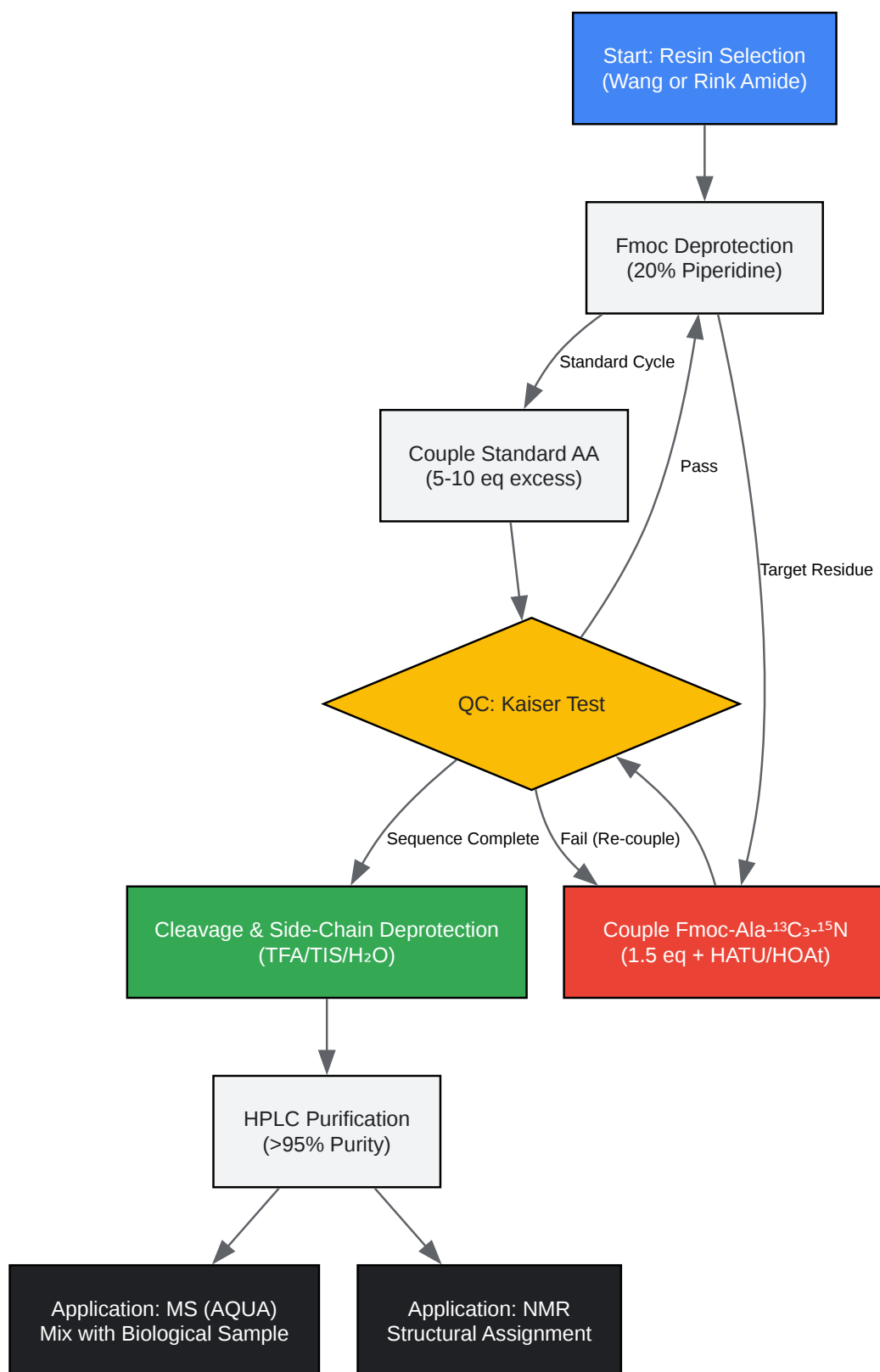

[Click to download full resolution via product page](#)

Caption: Integrated workflow for incorporating high-value isotopic reagents into SPPS.

Part 4: Quality Control & Validation

To ensure the integrity of the labeled peptide, the following validation steps are mandatory before application:

- Isotopic Incorporation Check (High-Res MS):
 - Verify the mass spectrum shows the expected +4 Da shift per labeled Alanine.
 - Acceptance Criteria: < 1% unlabeled (M-4) species to ensure quantitative accuracy.
- Chiral Purity Analysis (C18-HPLC or GC-MS):
 - Alanine is generally resistant to racemization, but activation with HATU requires careful base control.
 - Acceptance Criteria: < 0.5% D-Alanine isomer.

References

- Gerber, S. A., et al. (2003). "Absolute quantification of proteins and phosphoproteins from cell lysates by tandem MS." *Proceedings of the National Academy of Sciences*, 100(12), 6940-6945. [[Link](#)]
- Kettenbach, A. N., et al. (2011). "Absolute quantification of protein and post-translational modification abundance with stable isotope-labeled synthetic peptides."^[1]^[2] *Nature Protocols*, 6, 175-186. [[Link](#)]

Need Custom Synthesis?

BenchChem offers custom synthesis for rare earth carbides and specific isotopic labeling.

Email: info@benchchem.com or [Request Quote Online](#).

Sources

- [1. Absolute quantification of protein and post-translational modification abundance with stable isotope-labeled synthetic peptides - PubMed \[pubmed.ncbi.nlm.nih.gov\]](#)

- [2. Absolute Quantitative Analysis \(AQUA\) Service | MtoZ Biolabs \[mtoz-biolabs.com\]](#)
- To cite this document: BenchChem. [Technical Guide: Strategic Implementation of Double-Labeled Fmoc-Alanine in Peptide Synthesis]. BenchChem, [2026]. [Online PDF]. Available at: [<https://www.benchchem.com/product/b1580352/docs#technical-guide-strategic-implementation-of-double-labeled-fmoc-alanine-in-peptide-synthesis>]

Disclaimer & Data Validity:

The information provided in this document is for Research Use Only (RUO) and is strictly not intended for diagnostic or therapeutic procedures. While BenchChem strives to provide accurate protocols, we make no warranties, express or implied, regarding the fitness of this product for every specific experimental setup.

Technical Support: The protocols provided are for reference purposes. Unsure if this reagent suits your experiment?

Need Industrial/Bulk Grade? [Request Custom Synthesis Quote](#)

BenchChem

Our mission is to be the trusted global source of essential and advanced chemicals, empowering scientists and researchers to drive progress in science and industry.

Contact

Address: 3281 E Guasti Rd
Ontario, CA 91761, United States
Phone: (601) 213-4426
Email: info@benchchem.com

[Contact our Ph.D. Support Team for a compatibility check](#)