

Technical Guide: Maximum Incremental Reactivity (MIR) of *trans*-3-Methyl-2-pentene

Author: BenchChem Technical Support Team. **Date:** May 2026

Compound of Interest

Compound Name: *trans*-3-Methyl-2-pentene

CAS No.: 616-12-6

Cat. No.: B1580960

[Get Quote](#)

Executive Summary

The Bottom Line: ***trans*-3-Methyl-2-pentene** (CAS: 4457-63-4) is a highly reactive trisubstituted alkene with a Maximum Incremental Reactivity (MIR) value of 13.17 g O₃/g VOC (SAPRC-07 scale).

This value places it in the upper tier of ozone-forming volatile organic compounds (VOCs), significantly exceeding the reactivity of standard solvents like toluene (~4.0) or ethanol (~1.5). For drug development and chemical manufacturing professionals, this molecule represents a critical "bad actor" in solvent impurity profiles. Its presence, even in trace amounts within bulk solvents or exhaust streams, can disproportionately impact facility emissions compliance (Title V permitting) due to its rapid kinetics with hydroxyl radicals (OH) and high yield of secondary oxidants.

The Physicochemical Basis[1]

To understand the MIR value, one must understand the structural drivers of the molecule's instability in the troposphere.

trans-3-Methyl-2-pentene is a trisubstituted internal alkene.[1][2] Its high reactivity is governed by the electron density of the carbon-carbon double bond (

).

Property	Value/Description	Impact on Reactivity
Molecular Structure		Trisubstitution stabilizes the resulting radical intermediates (hyperconjugation), lowering the activation energy for electrophilic attack.
Stereochemistry	trans (E-isomer)	Steric accessibility allows for rapid approach of OH radicals compared to more hindered isomers.
Electronic Effect	Inductive (+I)	Three alkyl groups donate electron density to the -system, making it highly attractive to electrophiles like OH• and

The MIR Value: Data & Derivation

The MIR scale, developed by Dr. William P.L.[3] Carter, quantifies the amount of ozone formed per gram of VOC added to a reference atmosphere under high-NOx conditions (where ozone formation is VOC-limited).

Comparative Reactivity Table (SAPRC-07 Scale)

The following table contextualizes the reactivity of **trans-3-Methyl-2-pentene** against common pharmaceutical solvents and related alkenes.

Compound	CAS Number	MIR (g O ₃ / g VOC)	Classification
trans-3-Methyl-2-pentene	4457-63-4	13.17	High Reactivity
cis-3-Methyl-2-pentene	15918-08-8	12.84	High Reactivity
1-Pentene	109-67-1	7.79	Moderate Reactivity
Toluene	108-88-3	3.97	Standard Reference
Acetone	67-64-1	0.36	Exempt/Low
Ethane	74-84-0	0.28	Baseline

Data Source: Carter, W. P. L. (2010).^{[3][4][5][6][7]} SAPRC-07 Chemical Mechanism and Updated Ozone Reactivity Scales.

Interpretation for Process Chemists

If your facility emits 1 kg of **trans-3-Methyl-2-pentene**, it has the potential to generate 13.17 kg of Ozone downwind under worst-case conditions. In contrast, emitting 1 kg of Acetone generates only 0.36 kg of Ozone. This 36x difference highlights why "mass-based" emission limits are often superseded by "reactivity-based" limits in non-attainment zones (e.g., California).

Mechanistic Pathways: The "Signaling" of Ozone Formation

The high MIR value is driven by the molecule's rapid degradation pathway. The primary "signal" for ozone formation is the conversion of nitric oxide (NO) to nitrogen dioxide (

) by peroxy radicals (

) generated during the alkene's oxidation.

Reaction Mechanism (OH Radical Attack)

The dominant daytime loss mechanism is the addition of the Hydroxyl radical (OH) to the double bond.

- Electrophilic Addition: OH adds to the less substituted carbon (C2) or the more substituted carbon (C3), forming a -hydroxy alkyl radical.
- Peroxy Formation: The alkyl radical reacts instantly with to form a peroxy radical ().
- NO Oxidation (The Ozone Driver): The transfers an oxygen atom to NO, forming and an alkoxy radical (). This is the rate-limiting step for ozone accumulation.
- Fragmentation: The alkoxy radical cleaves to form stable carbonyls: Acetaldehyde and Methyl Ethyl Ketone (MEK).

Pathway Visualization

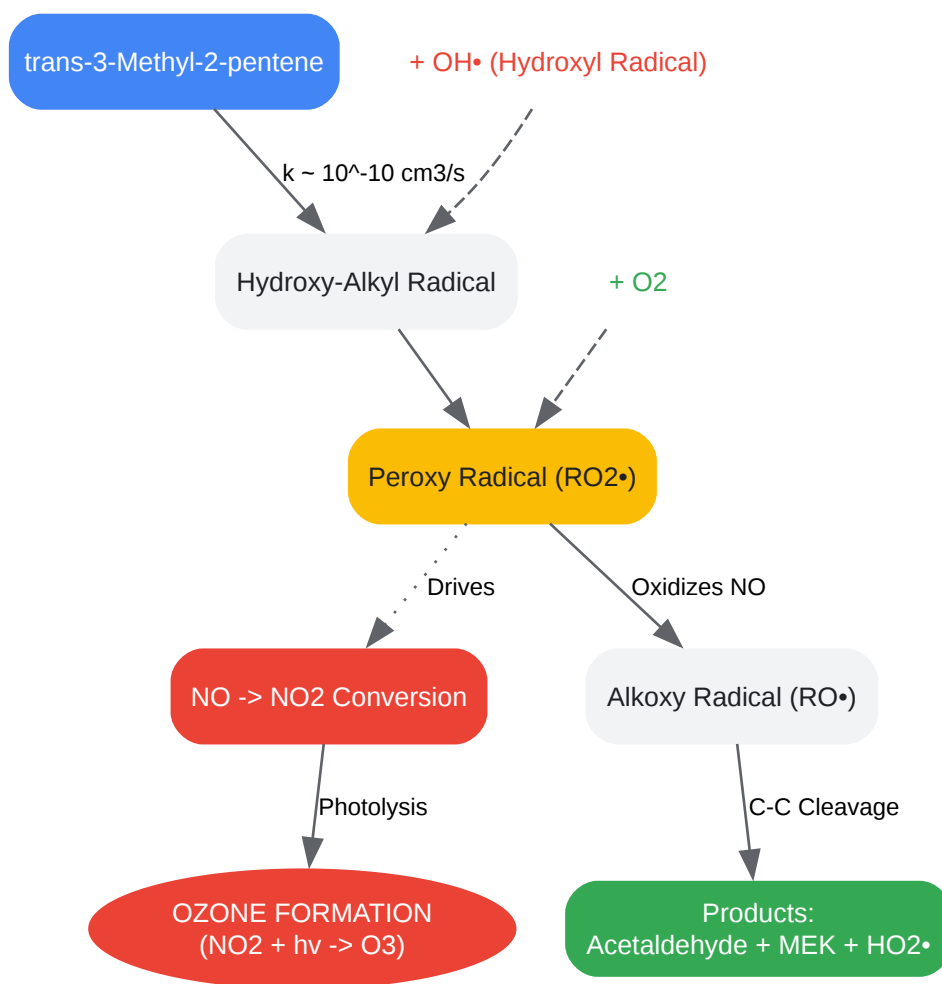

[Click to download full resolution via product page](#)

Figure 1: The OH-initiated oxidation pathway of **trans-3-Methyl-2-pentene**.^[8] The red node highlights the critical NO_x interaction step that defines the MIR value.

Experimental Methodology: Measuring MIR

MIR values are not theoretical guesses; they are empirically derived from environmental chamber experiments. For researchers validating these values or assessing new solvent mixtures, the following protocol is the industry standard.

The Smog Chamber Protocol

The experiment measures the "Incremental Reactivity" (IR) by comparing a "Base Case" (surrogate atmosphere) vs. a "Test Case" (Base + Target VOC).

Protocol Steps:

- Chamber Prep: Use a Teflon-film reactor (dual-chamber for control/test) to minimize wall effects.
- Base Mixture Injection: Inject a standard "urban soup" of VOCs (ethylene, propylene, toluene, etc.) and NO_x to simulate a polluted city environment.
- Target Injection: Inject **trans-3-Methyl-2-pentene** into one side of the chamber only.
- Irradiation: Expose both sides to blacklights (UV) or natural sunlight for 6–10 hours.
- Analysis: Monitor

formation continuously via UV photometry; monitor VOC decay via GC-FID.

Workflow Diagram

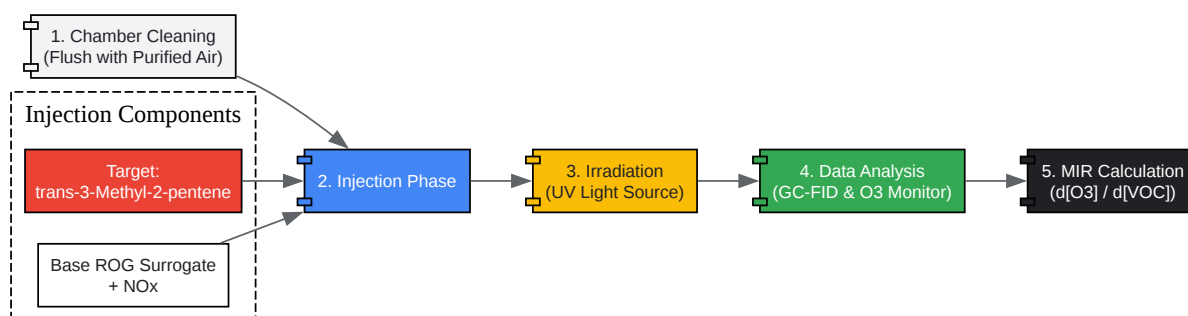

[Click to download full resolution via product page](#)

Figure 2: Standard Operating Procedure (SOP) for determining MIR values via Environmental Chamber experiments.

References

- Carter, W. P. L. (2010).^{[3][6][7]} Development of the SAPRC-07 Chemical Mechanism and Updated Ozone Reactivity Scales. California Air Resources Board (CARB).^[7]

- California Air Resources Board. (2023).[7] Regulation for Reducing Emissions from Consumer Products - MIR Tables.
- Atkinson, R., & Arey, J. (2003). Atmospheric Degradation of Volatile Organic Compounds. *Chemical Reviews*, 103(12), 4605–4638.
- U.S. EPA. (2024). Technical Guidance on the Reactivity of Volatile Organic Compounds.

Need Custom Synthesis?

BenchChem offers custom synthesis for rare earth carbides and specific isotopic labeling.

Email: info@benchchem.com or [Request Quote Online](#).

Sources

1. intra.engr.ucr.edu [intra.engr.ucr.edu]
 2. ww2.arb.ca.gov [ww2.arb.ca.gov]
 3. downloads.regulations.gov [downloads.regulations.gov]
 4. intra.cert.ucr.edu [intra.cert.ucr.edu]
 5. acp.copernicus.org [acp.copernicus.org]
 6. researchgate.net [researchgate.net]
 7. intra.engr.ucr.edu [intra.engr.ucr.edu]
 8. researchgate.net [researchgate.net]
- To cite this document: BenchChem. [Technical Guide: Maximum Incremental Reactivity (MIR) of trans-3-Methyl-2-pentene]. BenchChem, [2026]. [Online PDF]. Available at: [<https://www.benchchem.com/product/b1580960/docs#technical-guide-maximum-incremental-reactivity-mir-of-trans-3-methyl-2-pentene>]

Disclaimer & Data Validity:

The information provided in this document is for Research Use Only (RUO) and is strictly not intended for diagnostic or therapeutic procedures. While BenchChem strives to provide

accurate protocols, we make no warranties, express or implied, regarding the fitness of this product for every specific experimental setup.

Technical Support: The protocols provided are for reference purposes. Unsure if this reagent suits your experiment?

Need Industrial/Bulk Grade? [Request Custom Synthesis Quote](#)

BenchChem

Our mission is to be the trusted global source of essential and advanced chemicals, empowering scientists and researchers to drive progress in science and industry.

Contact

Address: 3281 E Guasti Rd

Ontario, CA 91761, United States

Phone: (601) 213-4426

Email: info@benchchem.com

[Contact our Ph.D. Support Team for a compatibility check](#)