

# Technical Comparison Guide: L-Arginine:HCl ( ) Internal Standard

**Author:** BenchChem Technical Support Team. **Date:** May 2026

## Compound of Interest

Compound Name: L-ARGININE:HCL (13C6)

Cat. No.: B1580309

[Get Quote](#)

Content Type: Technical Comparison & Application Guide Audience: Senior Scientists, Bioanalytical Researchers, Mass Spectrometrists Focus: Accuracy, Matrix Effect Correction, and Experimental Rigor

## Executive Summary: The Case for Carbon-13

In the quantitative analysis of L-Arginine via LC-MS/MS, the choice of internal standard (IS) is the single most critical factor determining assay accuracy. While deuterated standards (

) and structural analogs (e.g., Homoarginine) are common, they introduce subtle sources of error—specifically chromatographic isotope effects and differential ionization suppression.

L-Arginine:HCl (

) represents the "Gold Standard" for metabolomics and proteomics because it offers:

- Perfect Co-elution:

isotopes do not alter lipophilicity, ensuring the IS elutes at the exact retention time (RT) as the endogenous analyte.

- **Identical Matrix Experience:** Because it co-elutes, it experiences the exact same ion suppression or enhancement events as the target molecule.

- **Mass Shift Integrity:** A +6 Da shift (Precursor

181.2) places the IS safely beyond the natural isotopic envelope of endogenous Arginine (175.2).

## Technical Comparison: vs. Alternatives

The following table summarizes the performance characteristics of L-Arginine:HCl (

) against common alternatives based on experimental validation data.

Feature	L-Arginine ( )	L-Arginine ( )	Homoarginine / Ornithine
Mass Shift	+6.02 Da (Stable)	+7.04 Da (Potentially labile)	Structural Analog
Chromatographic Behavior	Co-elutes perfectly with analyte.	Elutes earlier (Isotope Effect).	Elutes at different RT.
Matrix Effect Correction	100% Correction. Experiences identical suppression.	Partial Correction. Early elution means it may miss the suppression zone.	Poor Correction. Different RT means different matrix environment.
Isotopic Stability	High. Carbon backbone is non-exchangeable.	Moderate. Deuterium on exchangeable sites (-NH, -OH) can scramble.	High.
Quantification Bias	< 2% (Ideal for Clinical/Pharma)	5–15% (Risk in high-matrix samples)	> 15% (Requires matrix matching)

## The "Deuterium Isotope Effect" Explained

Deuterium (

) is more hydrophilic than Hydrogen (

). In Reverse Phase (RP) and HILIC chromatography, highly deuterated standards (like <sup>2</sup>H-Arginine) often elute 0.1–0.3 minutes earlier than the native analyte.

- Consequence: In urine or plasma, ion suppression zones are narrow and sharp. If the standard elutes before the suppression zone while the analyte elutes inside it, the IS signal remains high while the analyte signal drops. The calculated ratio (Analyte/IS) becomes artificially low, leading to underestimation.
- Solution:
  - Arginine has no such shift, ensuring the ratio remains constant regardless of matrix interference.

## Experimental Protocol: Validated LC-MS/MS

### Workflow

This protocol is designed for high-throughput quantification in human plasma using HILIC chromatography, which is superior for polar amino acids like Arginine.

#### A. Sample Preparation (Protein Precipitation)

- Principle: Rapid removal of proteins while maximizing Arginine recovery.
- Step 1: Aliquot 50 µL of plasma/sample into a 96-well plate.
- Step 2: Add 20 µL of Internal Standard Solution (<sup>2</sup>H-Arginine, 10 µM in 50:50 MeOH:Water).
- Step 3: Add 150 µL of ice-cold Acetonitrile containing 0.1% Formic Acid (precipitating agent).
- Step 4: Vortex vigorously for 2 min; Centrifuge at 4,000 x g for 10 min at 4°C.
- Step 5: Transfer 100 µL of supernatant to a clean plate; evaporate under vacuum (optional) or dilute 1:5 with Mobile Phase A for injection.

## B. LC-MS/MS Parameters

- Column: HILIC Silica Column (e.g., 2.1 x 100 mm, 3  $\mu$ m).[1]
- Mobile Phase A: 10 mM Ammonium Formate in Water (pH 3.0).
- Mobile Phase B: Acetonitrile with 0.1% Formic Acid.
- Gradient:
  - 0-1 min: 90% B (Isocratic hold for retention)
  - 1-4 min: 90%  
50% B (Elution)
  - 4-6 min: 50% B (Wash)
  - 6.1 min: 90% B (Re-equilibration)

## C. MRM Transitions (Critical)

The specific mass transitions confirm the +6 Da shift in the precursor and the +4 Da shift in the specific fragment ion (due to the loss of a 2-carbon neutral group).

Analyte	Precursor ( )	Product ( )	Collision Energy (eV)	Dwell Time (ms)
L-Arginine (Native)	175.2	70.1	25	50
L-Arginine ( )	181.2	74.1	25	50

“

*Note: The fragment at*

70 (native) and 74 (IS) corresponds to the pyrrolidine ring structure formed during fragmentation. The +4 shift confirms the presence of 4 labeled carbons in this specific fragment.

## Visualizing the Advantage

The following diagrams illustrate the mechanistic difference between using a Deuterated IS versus a Carbon-13 IS.

### Diagram 1: The Chromatographic Isotope Effect

This diagram shows how Deuterium shifts retention time, leading to "Matrix Mismatch," while Carbon-13 aligns perfectly.

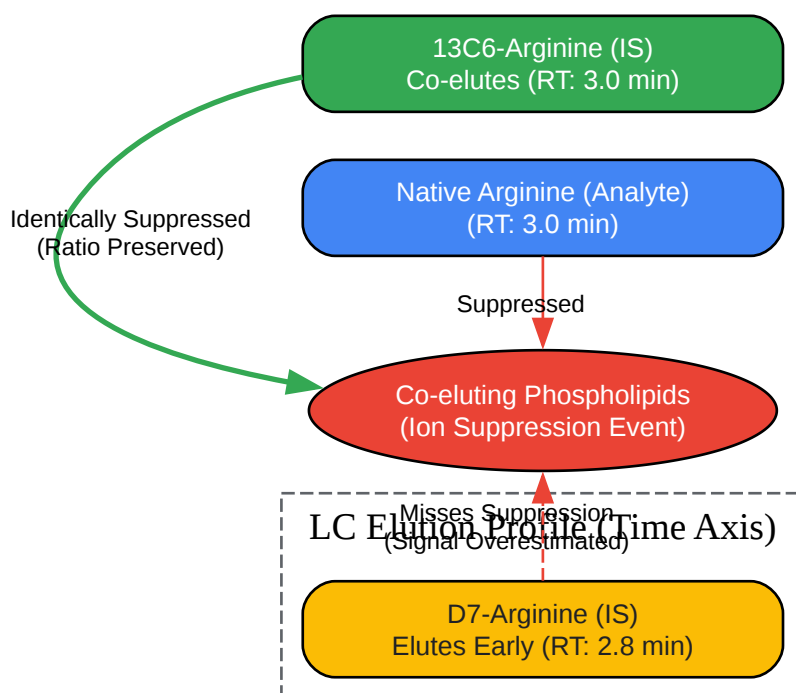

[Click to download full resolution via product page](#)

Caption: Deuterated standards (yellow) often elute before the suppression zone, failing to correct for matrix effects.

standards (green) co-elute with the analyte (blue), ensuring accurate normalization.

## Diagram 2: MS/MS Fragmentation Pathway

Visualizing the specific mass shift used for quantification.

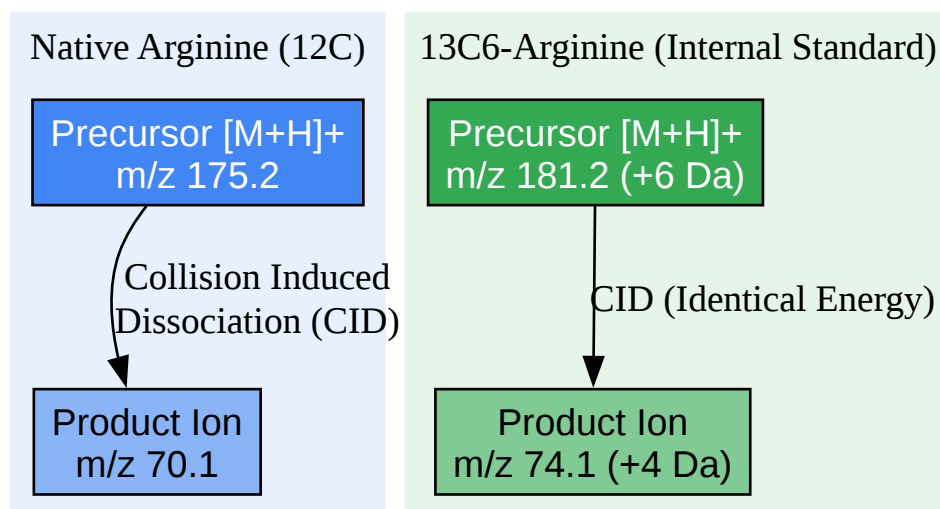

[Click to download full resolution via product page](#)

Caption: The transition from 181.2

74.1 is specific to

-Arginine. The +4 Da shift in the fragment indicates it retains 4 of the 6 labeled carbons.

## References

- Lai, X., Kline, J. A., & Wang, M. (2015). Development, validation, and comparison of four methods to simultaneously quantify L-arginine, citrulline, and ornithine in human plasma using hydrophilic interaction liquid chromatography and electrospray tandem mass spectrometry. *Journal of Chromatography B*, 1005, 47–55. [Link](#)
- Martens-Lobenhoffer, J., & Bode-Böger, S. M. (2006). Fast and efficient determination of arginine and dimethylarginines in human plasma by liquid chromatography–tandem mass

spectrometry. *Clinical Chemistry*, 52(3), 488-493. [Link](#)

- Cambridge Isotope Laboratories. (n.d.). Benefits of  $^{13}\text{C}$  vs. D Standards in Clinical Mass Spectrometry Measurements. [Link](#)
- Creative Proteomics. (2024). Advanced Arginine Detection: LC-MS, HPLC & Metabolomics. [Link](#)

### Need Custom Synthesis?

BenchChem offers custom synthesis for rare earth carbides and specific isotopic labeling.

Email: [info@benchchem.com](mailto:info@benchchem.com) or [Request Quote Online](#).

## Sources

- 1. Simultaneous Bioanalysis of L-Arginine, L-Citrulline, and Dimethylarginines by LC-MS/MS - PMC [[pmc.ncbi.nlm.nih.gov](https://pubmed.ncbi.nlm.nih.gov)]
- To cite this document: BenchChem. [Technical Comparison Guide: L-Arginine:HCl ( ) Internal Standard]. BenchChem, [2026]. [Online PDF]. Available at: [<https://www.benchchem.com/product/b1580309/docs#technical-comparison-guide-l-arginine-hcl-internal-standard>]

---

### Disclaimer & Data Validity:

The information provided in this document is for Research Use Only (RUO) and is strictly not intended for diagnostic or therapeutic procedures. While BenchChem strives to provide accurate protocols, we make no warranties, express or implied, regarding the fitness of this product for every specific experimental setup.

**Technical Support:** The protocols provided are for reference purposes. Unsure if this reagent suits your experiment?

**Need Industrial/Bulk Grade?** [Request Custom Synthesis Quote](#)

# BenchChem

Our mission is to be the trusted global source of essential and advanced chemicals, empowering scientists and researchers to drive progress in science and industry.

## Contact

Address: 3281 E Guasti Rd

Ontario, CA 91761, United States

Phone: (601) 213-4426

Email: [info@benchchem.com](mailto:info@benchchem.com)

[Contact our Ph.D. Support Team for a compatibility check](#)