

Application Note: NMR Chemical Shift Assignment of Beta-Alanine (3- ¹³C)

Author: BenchChem Technical Support Team. **Date:** May 2026

Compound of Interest

Compound Name: BETA-ALANINE (3-¹³C)

Cat. No.: B1580244

[Get Quote](#)

-Alanine

Executive Summary

This application note provides a comprehensive guide for the detection, assignment, and validation of

-alanine (3-

C) using Nuclear Magnetic Resonance (NMR) spectroscopy. Unlike

-amino acids,

-alanine contains a backbone methylene group inserted between the amino and carboxyl moieties, altering its electronic environment and spectral signature.

The 3-

C isotopologue (labeled at the

-position adjacent to the nitrogen) is a critical tracer in metabolic flux analysis (carnosine synthesis), a structural probe in solid-state NMR (SSNMR) for peptide spacers, and a reference standard for spectrometer calibration. This guide details protocols for both solution-state (pH-

dependent) and solid-state (CP-MAS) assignment, ensuring rigorous identification of the labeled site against natural abundance background.

Chemical Identity & Theoretical Framework

Molecular Structure and Labeling

To ensure accurate assignment, we must first define the IUPAC numbering system used throughout this protocol.

-alanine is systematically named 3-aminopropanoic acid.[\[1\]](#)[\[2\]](#)[\[3\]](#)

- C1: Carboxyl carbon (

)

- C2:

-Methylene carbon (

)

- C3:

-Methylene carbon (

) [LABELED SITE]

Target Molecule:

-alanine (3-

C) Formula:

[\[1\]](#)[\[2\]](#)

Spectral Expectations

- 1D

C {1H}: The spectrum will be dominated by a high-intensity singlet at the C3 position. C1 and C2 will appear as weak natural abundance signals (approx. 1.1% intensity relative to the label).

- Coupling (): Because the sample is singly labeled, no strong coupling will be observed unless the sample is enriched at multiple sites. However, satellites may be visible around the C3 peak due to coupling with natural abundance C2 ().
- Coupling (): In non-decoupled experiments, C3 will appear as a triplet () due to the two attached protons.

Protocol A: Solution-State NMR Assignment

Objective: unambiguous assignment of the C3 resonance and verification of label enrichment.

Sample Preparation

- Solvent: Dissolve 5–10 mg of β -alanine ($3\text{-}^{13}\text{C}$) in 600 μL of Deuterium Oxide (D_2O , 99.9% D).
- Reference: Add 0.5 mM DSS (4,4-dimethyl-4-silapentane-1-sulfonic acid) or TSP as an internal chemical shift reference (0 ppm).
- pH Adjustment (Critical):
 - alanine is zwitterionic at neutral pH.
 - Standard Condition: Adjust pH to 7.0 using dilute DCl or NaOD.
 - Note: Chemical shifts are highly pH-dependent. See Section 5 for pH titration data.

Acquisition Parameters (Bruker/Varian Standard)

- Pulse Sequence:zgpg30 (Power-gated decoupling) or dept135 (for phase validation).
- Relaxation Delay (D1): Set to

. For the labeled C3,

is typically 2–4 seconds. Set D1 = 10–15s for quantitative integration; 2s is sufficient for assignment.
- Scans (NS): 16–64 scans (Signal is enhanced by enrichment; extensive averaging is unnecessary).
- Temperature: 298 K (25°C).

Workflow Diagram: Solution Assignment

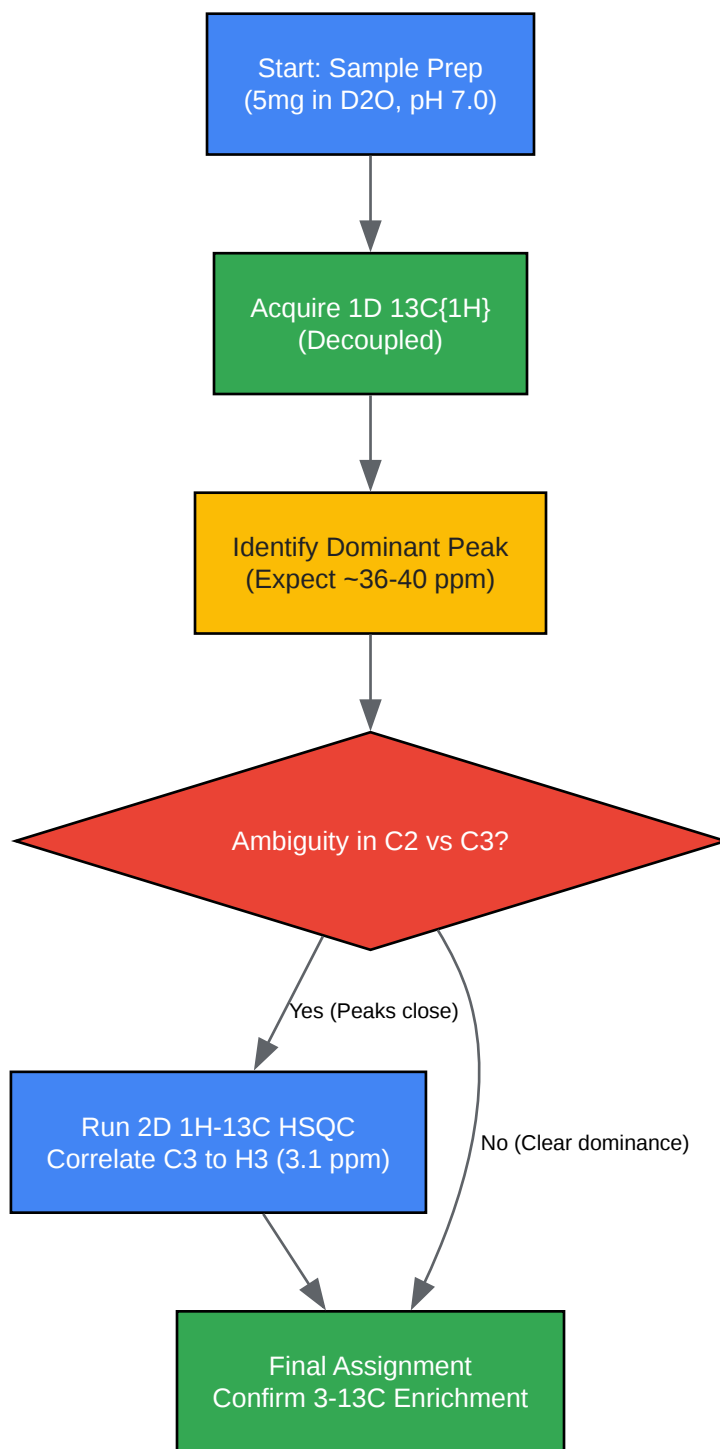

[Click to download full resolution via product page](#)

Figure 1: Decision tree for solution-state assignment. If the C2 and C3 natural abundance signals interfere, HSQC provides orthogonal validation.

Protocol B: Solid-State NMR (CP-MAS)

Objective: Use

-alanine (3-

C) as a secondary reference or to study conformation in solid matrices.

Instrumental Setup

- Technique: Cross-Polarization Magic Angle Spinning (CP-MAS).
- Rotor: 3.2 mm or 4 mm Zirconia rotor.
- Spin Rate: 8–12 kHz (sufficient to push spinning sidebands outside the aliphatic region).
- Contact Time: 1–2 ms (optimized for groups).
- Decoupling: High-power proton decoupling (SPINAL-64 or TPPM) is mandatory.

Referencing Strategy

Solid-state shifts often differ from solution shifts due to packing effects and lack of solvent shielding.

- Primary Reference: Set the carbonyl peak of an external Glycine standard to 176.03 ppm.
- Secondary Validation: The labeled C3 peak of -alanine should appear at 38.4 ppm (crystalline form).

Data Analysis & Chemical Shift Assignment

The following table synthesizes data from the Human Metabolome Database (HMDB) and Biological Magnetic Resonance Data Bank (BMRB) for neutral pH conditions.

Chemical Shift Table (Solution State, D₂O, pH 7.0)

Carbon Position	IUPAC Label	(ppm)	Multiplicity (Decoupled)	Multiplicity (Coupled)	Notes
Carboxyl	C1	176.0 – 181.0	Singlet	Singlet	Natural Abundance (Weak)
-Methylene	C2	34.0 – 36.3	Singlet	Triplet ()	Natural Abundance (Weak)
-Methylene	C3	36.0 – 39.5	Singlet (Strong)	Triplet ()	Enriched Signal (Dominant)

Note: The C3 signal is typically downfield (higher ppm) of C2 due to the deshielding effect of the adjacent Nitrogen atom.

pH Dependence (Expert Insight)

Researchers must account for pH drift, which significantly shifts the C1 and C3 peaks.

- Acidic (pH < 3): Carboxyl protonated. C1 shifts upfield (~176 ppm).
- Basic (pH > 10): Amine deprotonated. C3 shifts upfield significantly (shielding increases as).

Validation via 2D HSQC

To confirm the label is at position 3 (and not 2), correlate with proton shifts:

- H3 Protons (): ppm (Triplet).
- H2 Protons ()

):

ppm (Triplet).

- Validation: The strong

C signal at ~39 ppm must correlate with the proton signal at ~3.18 ppm.

Metabolic Pathway Visualization

-alanine is a precursor to Carnosine. In drug development, tracking the 3-

C label into Carnosine confirms uptake and synthesis.

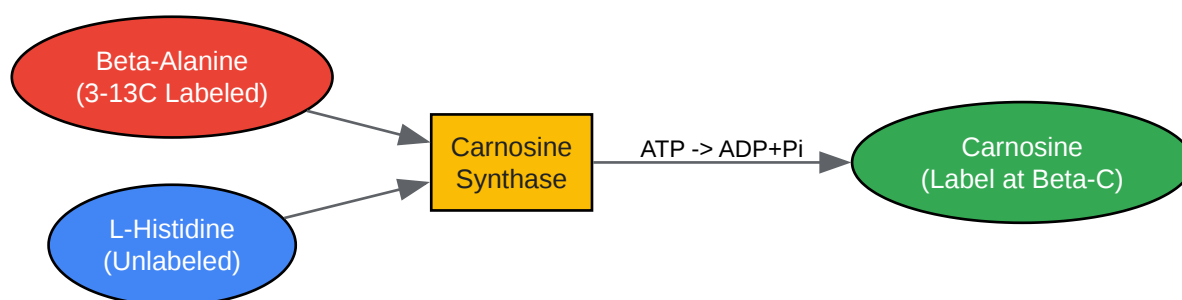

[Click to download full resolution via product page](#)

Figure 2: Metabolic incorporation of labeled

-alanine into Carnosine. The 3-

C label is retained in the final dipeptide.

Troubleshooting & Quality Control

Observation	Probable Cause	Corrective Action
Split Peak at C3	Coupling	If the sample is dual-labeled (e.g., U-C), C3 will be a doublet. If singly labeled, check for contamination.
Broad Lines (Solution)	pH exchange or aggregation	Ensure pH is stable (buffer with phosphate if permissible) or increase temperature to 300K.
Missing Signal (Solid)	Low CP efficiency	Optimize contact time. Aliphatic carbons () require different Hartmann-Hahn matching than carbonyls.
Chemical Shift Offset	pH mismatch	Measure pH of the NMR tube directly. A 0.5 pH unit difference can shift peaks by 0.5–1.0 ppm.

References

- Human Metabolome Database (HMDB).Metabocard for Beta-Alanine (HMDB0000056). [\[Link\]](#)
- Biological Magnetic Resonance Data Bank (BMRB).Entry bmse000159 - Beta-Alanine.[\[3\]](#)[\[4\]](#) [\[Link\]](#)[\[3\]](#)[\[5\]](#)
- PubChem.Beta-Alanine Compound Summary. [\[Link\]](#)

Need Custom Synthesis?

BenchChem offers custom synthesis for rare earth carbides and specific isotopic labeling.

Email: info@benchchem.com or [Request Quote Online](#).

Sources

- [1. isotope.com \[isotope.com\]](#)
- [2. isotope.com \[isotope.com\]](#)
- [3. Beta-Alanine | C3H7NO2 | CID 239 - PubChem \[pubchem.ncbi.nlm.nih.gov\]](#)
- [4. bmse000159 Beta-Alanine at BMRB \[bmr.io\]](#)
- [5. rsc.org \[rsc.org\]](#)
- To cite this document: BenchChem. [Application Note: NMR Chemical Shift Assignment of Beta-Alanine (3- C)]. BenchChem, [2026]. [Online PDF]. Available at: [\[https://www.benchchem.com/product/b1580244/docs#application-note-nmr-chemical-shift-assignment-of-beta-alanine-3-c\]](https://www.benchchem.com/product/b1580244/docs#application-note-nmr-chemical-shift-assignment-of-beta-alanine-3-c)

Disclaimer & Data Validity:

The information provided in this document is for Research Use Only (RUO) and is strictly not intended for diagnostic or therapeutic procedures. While BenchChem strives to provide accurate protocols, we make no warranties, express or implied, regarding the fitness of this product for every specific experimental setup.

Technical Support: The protocols provided are for reference purposes. Unsure if this reagent suits your experiment?

Need Industrial/Bulk Grade? [Request Custom Synthesis Quote](#)

BenchChem

Our mission is to be the trusted global source of essential and advanced chemicals, empowering scientists and researchers to drive progress in science and industry.

Contact

Address: 3281 E Guasti Rd
Ontario, CA 91761, United States
Phone: (601) 213-4426
Email: info@benchchem.com

Contact our Ph.D. Support Team for a compatibility check