

Technical Support Center: Managing Halogenated Amino Acid Cleavage

Author: BenchChem Technical Support Team. **Date:** March 2026

Compound of Interest

Compound Name: *Fmoc-2,3-Dichloro-L-Phenylalanine*

Cat. No.: *B1579620*

[Get Quote](#)

Welcome to the Technical Support Center for Solid-Phase Peptide Synthesis (SPPS) focusing on the specific challenges of cleaving peptides containing halogenated amino acids. This guide is designed for researchers, scientists, and drug development professionals to navigate and troubleshoot potential side reactions, ensuring the integrity of your final peptide product.

Troubleshooting Guide: Side Reactions During Cleavage

This section addresses specific issues you may encounter during the cleavage of peptides containing halogenated residues.

Issue 1: Dehalogenation of the Peptide

Symptoms:

- Mass spectrometry (MS) analysis shows a peak corresponding to the peptide mass minus the mass of the halogen atom (e.g., -Cl, -Br, -I).
- Reduced yield of the desired halogenated peptide.
- Appearance of a new peak in the HPLC chromatogram with a different retention time.

Probable Cause: The primary cause of dehalogenation is the attack of reactive carbocations, generated from the cleavage of side-chain protecting groups (like tert-butyl) or the resin linker, on the electron-rich halogenated aromatic ring.[1][2] Certain scavengers, particularly those with strong reducing potential, can also contribute to this side reaction.

Solutions:

1. Optimize the Scavenger Cocktail: The choice of scavengers is critical to prevent the formation of reactive species that can cause dehalogenation.[1][3]

- For Chloro- and Bromo-phenylalanine: A standard "classic" cleavage cocktail is often sufficient.
 - Recommended Cocktail (Reagent K): TFA/Water/Phenol/Thioanisole/EDT (82.5:5:5:5:2.5 v/v).[2][4] This mixture provides a good balance of scavengers to trap various reactive species.
- For Iodo-phenylalanine: This residue is particularly susceptible to dehalogenation. A milder, more targeted scavenger cocktail is recommended.
 - Recommended "Odorless" Cocktail (Reagent B): TFA/Phenol/Water/Triisopropylsilane (TIPS) (88:5:5:2 v/v).[5][6] TIPS is a highly effective scavenger of trityl and other carbocations without the strong odor of thiol-based scavengers.[2][6]

Table 1: Recommended Scavenger Cocktails for Halogenated Amino Acids

Halogenated Residue	Recommended Cocktail	Composition (v/v)	Key Scavenger(s) & Rationale
4-Cl-Phe, 4-Br-Phe	Reagent K	TFA/H ₂ O/Phenol/Thioanisole/EDT (82.5:5:5:5:2.5)	EDT & Thioanisole: Effective at scavenging a broad range of carbocations.
4-I-Phe	Reagent B	TFA/Phenol/H ₂ O/TIPS (88:5:5:2)	TIPS: A potent scavenger for carbocations, minimizing the risk of reducing the C-I bond.

2. Minimize Cleavage Time: Prolonged exposure to strong acid can increase the likelihood of side reactions.[1][7]

- Experimental Protocol: Trial Cleavage to Optimize Time
 - Take a small amount of your peptide-resin (20-50 mg).[8]
 - Perform the cleavage using your chosen cocktail.
 - Take aliquots at different time points (e.g., 1, 2, and 4 hours).[8]
 - Precipitate the peptide from each aliquot with cold diethyl ether.[8]
 - Analyze each sample by HPLC and MS to determine the time point that provides the best yield of the desired product with minimal dehalogenation.[8]

Issue 2: Alkylation of Other Residues

Symptoms:

- MS analysis shows unexpected mass additions to the peptide, often corresponding to the mass of cleaved protecting groups (e.g., +56 for tert-butyl).
- Broad or shouldered peaks in the HPLC chromatogram.

Probable Cause: Insufficient scavenging allows carbocations generated during cleavage to react with nucleophilic side chains of other amino acids in your peptide, such as Tryptophan (Trp), Methionine (Met), or Tyrosine (Tyr).[2]

Solutions:

- **Ensure Adequate Scavenger Concentration:** Use a sufficient volume of the cleavage cocktail to fully swell the resin and ensure an excess of scavengers. A general guideline is 10-20 mL of cocktail per gram of resin.[9]
- **Select Appropriate Scavengers for Your Sequence:** If your peptide contains other sensitive residues, ensure your cocktail is designed to protect them. For example, if your peptide contains both a halogenated residue and Trp, using a cocktail with TIPS is highly recommended as it is an excellent scavenger for the cations that can modify the indole side chain.[2]

Frequently Asked Questions (FAQs)

Q1: What is the underlying mechanism of dehalogenation during TFA cleavage?

A1: During cleavage with Trifluoroacetic Acid (TFA), acid-labile side-chain protecting groups (e.g., tert-butyl from Asp, Glu, Ser, Thr, Tyr) and the resin linker are removed, generating highly reactive carbocations (e.g., the tert-butyl cation).[1][5] These electrophilic species can attack the electron-rich aromatic ring of a halogenated amino acid. In the case of iodo-phenylalanine, the C-I bond is the most susceptible to cleavage due to its lower bond energy compared to C-Br and C-Cl bonds, leading to the loss of iodine.

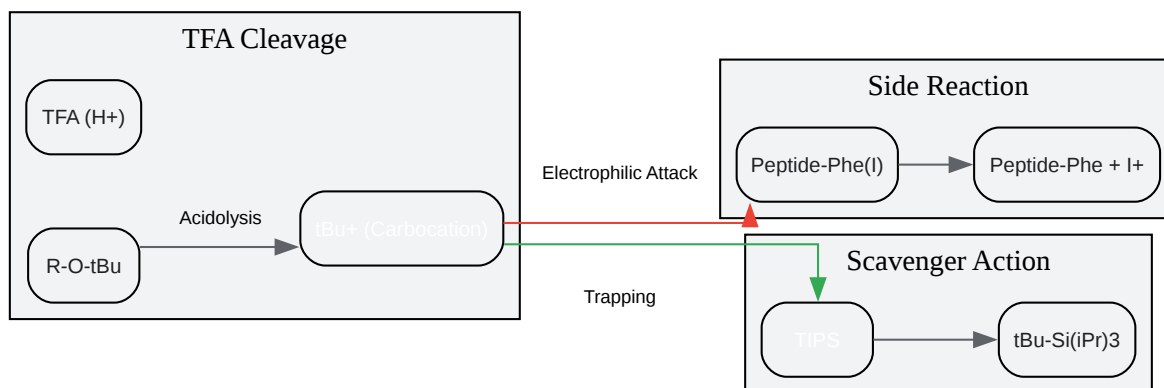

[Click to download full resolution via product page](#)

Caption: Mechanism of dehalogenation and scavenger protection.

Q2: Can I use a "universal" cleavage cocktail for all my peptides with halogenated amino acids?

A2: While "universal" cocktails like Reagent K are robust, they may not be optimal for all sequences, especially those containing sensitive residues like iodo-phenylalanine.[2] It is always best to choose a cleavage cocktail based on the specific amino acid composition of your peptide.[3][10] A small-scale trial cleavage is always recommended to verify the effectiveness of your chosen cocktail for a new peptide sequence.[8]

Q3: My peptide is still on the resin after the cleavage procedure. What should I do?

A3: Incomplete cleavage is a common issue. Before addressing the halogen-specific side reactions, you must first ensure the peptide is efficiently cleaved from the resin.

- Confirm Incomplete Cleavage: Use a ninhydrin test on a small sample of the resin beads after cleavage. A blue/purple color indicates the presence of free amines, meaning the peptide is still attached.[8]
- Troubleshoot the Cleavage:

- TFA Concentration: Ensure your TFA concentration is high enough for the resin linker used (typically >90% for standard resins like Wang or Rink Amide).[4]
- Reaction Time: Extend the cleavage time, monitoring for potential increases in side reactions.
- Resin Swelling: Ensure the resin is properly swelled in a suitable solvent (like DCM) before adding the cleavage cocktail to allow for efficient reagent penetration.[11]

Q4: How should I prepare my peptide-resin for cleavage?

A4: Proper preparation is crucial for a successful cleavage.

- Final Fmoc Removal: Ensure the N-terminal Fmoc group has been removed.
- Washing: Thoroughly wash the resin with Dichloromethane (DCM) to remove any residual DMF, which can interfere with the cleavage reaction.[12]
- Drying: Dry the peptide-resin under high vacuum for at least 4 hours, or preferably overnight. [2] This removes any residual solvents that could dilute the TFA.

Need Custom Synthesis?

BenchChem offers custom synthesis for rare earth carbides and specific isotopic labeling.

Email: info@benchchem.com or [Request Quote Online](#).

Sources

- [1. documents.thermofisher.com](https://documents.thermofisher.com) [documents.thermofisher.com]
- [2. merckmillipore.com](https://www.merckmillipore.com) [[merckmillipore.com](https://www.merckmillipore.com)]
- [3. selectscience.net](https://selectscience.net) [selectscience.net]
- [4. researchgate.net](https://www.researchgate.net) [[researchgate.net](https://www.researchgate.net)]
- [5. bpb-us-w2.wpmucdn.com](https://www.bpb-us-w2.wpmucdn.com) [[bpb-us-w2.wpmucdn.com](https://www.bpb-us-w2.wpmucdn.com)]
- [6. peptide.com](https://www.peptide.com) [[peptide.com](https://www.peptide.com)]
- [7. researchgate.net](https://www.researchgate.net) [[researchgate.net](https://www.researchgate.net)]

- [8. pdf.benchchem.com \[pdf.benchchem.com\]](https://pdf.benchchem.com)
- [9. renyi.hu \[renyi.hu\]](https://renyi.hu)
- [10. Fmoc Resin Cleavage and Deprotection \[sigmaaldrich.com\]](https://sigmaaldrich.com)
- [11. bpb-us-w2.wpmucdn.com \[bpb-us-w2.wpmucdn.com\]](https://bpb-us-w2.wpmucdn.com)
- [12. youtube.com \[youtube.com\]](https://youtube.com)
- To cite this document: BenchChem. [Technical Support Center: Managing Halogenated Amino Acid Cleavage]. BenchChem, [2026]. [Online PDF]. Available at: [\[https://www.benchchem.com/product/b1579620#reducing-side-reactions-during-cleavage-of-halogenated-amino-acids\]](https://www.benchchem.com/product/b1579620#reducing-side-reactions-during-cleavage-of-halogenated-amino-acids)

Disclaimer & Data Validity:

The information provided in this document is for Research Use Only (RUO) and is strictly not intended for diagnostic or therapeutic procedures. While BenchChem strives to provide accurate protocols, we make no warranties, express or implied, regarding the fitness of this product for every specific experimental setup.

Technical Support: The protocols provided are for reference purposes. Unsure if this reagent suits your experiment? [[Contact our Ph.D. Support Team for a compatibility check](#)]

Need Industrial/Bulk Grade? [Request Custom Synthesis Quote](#)

BenchChem

Our mission is to be the trusted global source of essential and advanced chemicals, empowering scientists and researchers to drive progress in science and industry.

Contact

Address: 3281 E Guasti Rd

Ontario, CA 91761, United States

Phone: (601) 213-4426

Email: info@benchchem.com