

A Comparative Guide to Alpha- and Beta-Defensins: Structure, Function, and Experimental Analysis

Author: BenchChem Technical Support Team. **Date:** April 2026

Compound of Interest

Compound Name: *Beta defensin*

Cat. No.: *B1578105*

[Get Quote](#)

For Researchers, Scientists, and Drug Development Professionals

This guide provides an objective comparison of the structure and function of alpha- and beta-defensins, two major families of host defense peptides critical to the innate immune system. We present a synthesis of experimental data, detailed methodologies for key assays, and visual diagrams to elucidate their distinct and overlapping roles.

Structural Comparison: Conserved Folds, Distinct Connections

Alpha- (α) and beta- (β) defensins are small (2-6 kDa), cationic, cysteine-rich peptides that share a characteristic three-stranded anti-parallel β -sheet core, which is stabilized by three intramolecular disulfide bonds.[1][2] Despite this shared fold, their defining structural difference lies in the connectivity of these disulfide bridges.[3]

- Alpha-Defensins: Exhibit a Cys I-VI, Cys II-IV, Cys III-V disulfide linkage pattern.[1][2] They are typically 29 to 35 amino acids in length.[4] In humans, they are found as human

neutrophil peptides (HNP1-4) in neutrophils and as human defensins (HD5, HD6) in the Paneth cells of the small intestine.[2][5][6]

- Beta-Defensins: Are characterized by a Cys I-V, Cys II-IV, Cys III-VI disulfide pairing.[2][3] They can be slightly longer, containing up to 45 amino acids.[4] Unlike the stored alpha-defensins, beta-defensins are more often produced by epithelial cells in response to microbial products or inflammatory cytokines.[7][8] Some beta-defensins, such as hBD-2, also feature a short α -helical segment at their N-terminus.[3][9]

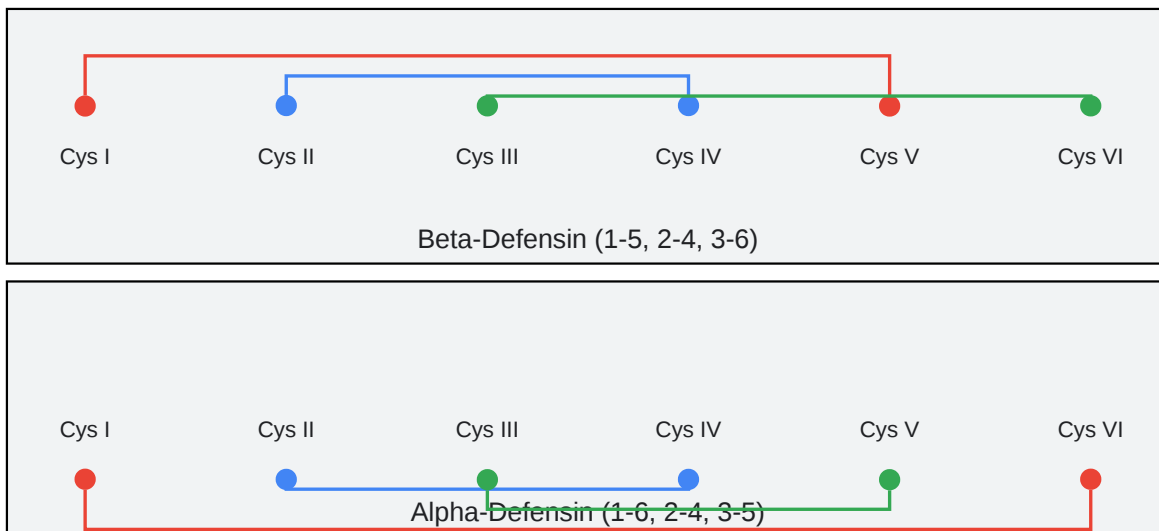

Figure 1: Disulfide Bridge Patterns

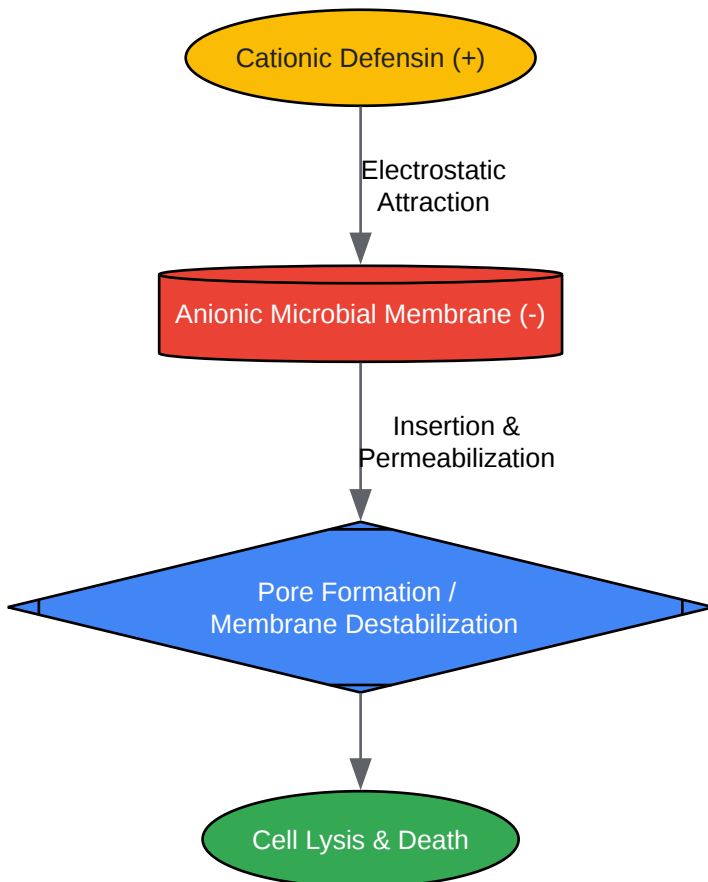

Figure 2: General Antimicrobial Mechanism

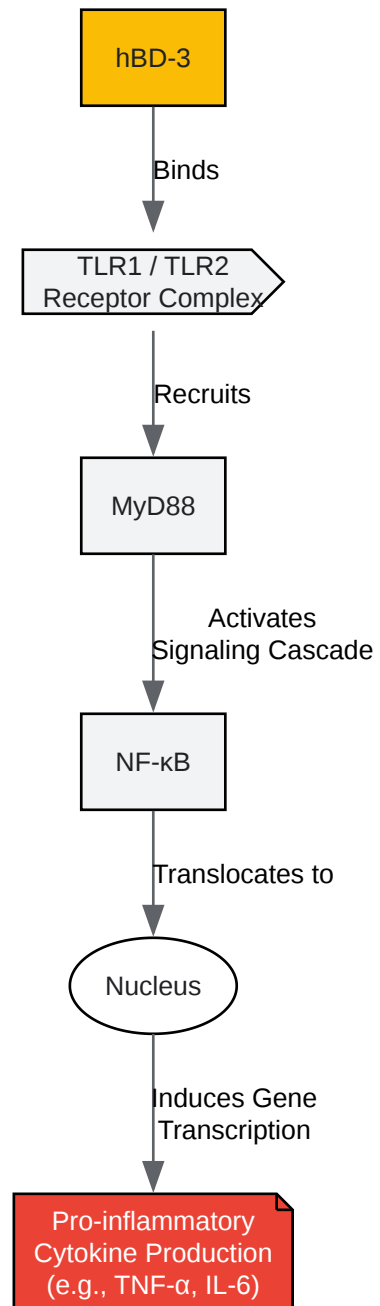

Figure 3: hBD-3 Signaling Pathway

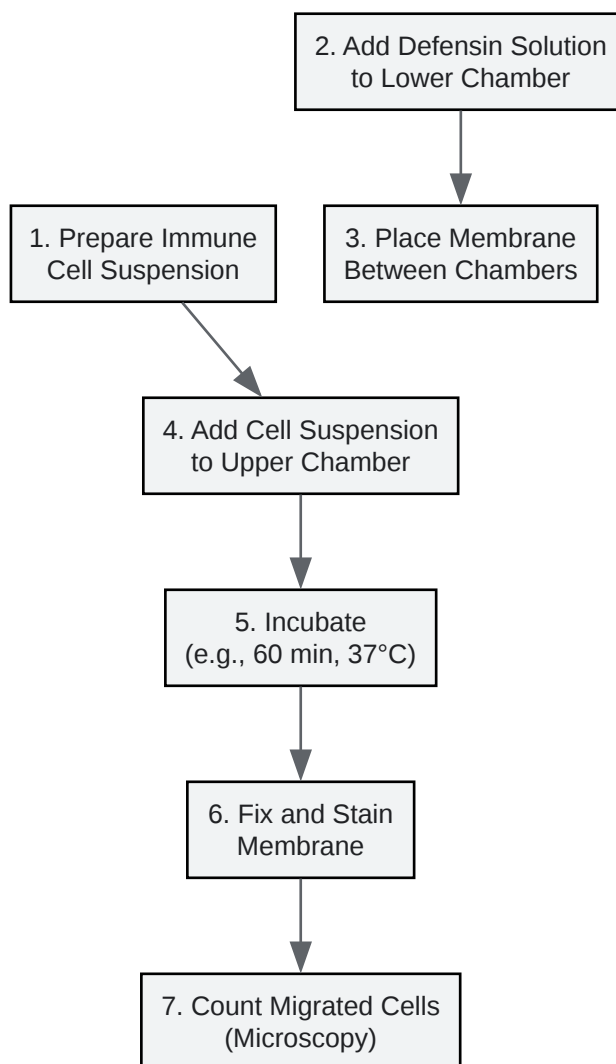

Figure 4: Chemotaxis Assay Workflow

[Click to download full resolution via product page](#)

Need Custom Synthesis?

BenchChem offers custom synthesis for rare earth carbides and specific isotopic labeling.

Email: info@benchchem.com or [Request Quote Online](#).

References

- 1. Human Defensins: Structure, Function, and Potential as Therapeutic Antimicrobial Agents with Highlights Against SARS CoV-2 - PMC [[pmc.ncbi.nlm.nih.gov](https://pubmed.ncbi.nlm.nih.gov/)]

- [2. Crystal structures of human \$\alpha\$ -defensins HNP4, HD5, and HD6 - PMC \[pmc.ncbi.nlm.nih.gov\]](#)
- [3. Structure determination of human and murine \$\beta\$ -defensins reveals structural conservation in the absence of significant sequence similarity - PMC \[pmc.ncbi.nlm.nih.gov\]](#)
- [4. Defensins and Other Antimicrobial Peptides and Proteins - PMC \[pmc.ncbi.nlm.nih.gov\]](#)
- [5. Alpha defensin - Wikipedia \[en.wikipedia.org\]](#)
- [6. taylorandfrancis.com \[taylorandfrancis.com\]](#)
- [7. Beta defensin - Wikipedia \[en.wikipedia.org\]](#)
- [8. Defensins: A Double-Edged Sword in Host Immunity - PMC \[pmc.ncbi.nlm.nih.gov\]](#)
- [9. Beta-defensin 2 - Wikipedia \[en.wikipedia.org\]](#)
- [To cite this document: BenchChem. \[A Comparative Guide to Alpha- and Beta-Defensins: Structure, Function, and Experimental Analysis\]. BenchChem, \[2026\]. \[Online PDF\]. Available at: \[https://www.benchchem.com/product/b1578105/docs#a-comparative-guide-to-alpha-and-beta-defensins-structure-function-and-experimental-analysis\]](#)

Disclaimer & Data Validity:

The information provided in this document is for Research Use Only (RUO) and is strictly not intended for diagnostic or therapeutic procedures. While BenchChem strives to provide accurate protocols, we make no warranties, express or implied, regarding the fitness of this product for every specific experimental setup.

Technical Support: The protocols provided are for reference purposes. Unsure if this reagent suits your experiment?

Need Industrial/Bulk Grade? [Request Custom Synthesis Quote](#)

BenchChem

Our mission is to be the trusted global source of essential and advanced chemicals, empowering scientists and researchers to drive progress in science and industry.

Contact

Address: 3281 E Guasti Rd
Ontario, CA 91761, United States
Phone: (601) 213-4426
Email: info@benchchem.com

Contact our Ph.D. Support Team for a compatibility check