

Technical Support Center: Cecropin-B Antimicrobial Susceptibility Testing (AST)

Author: BenchChem Technical Support Team. **Date:** May 2026

Compound of Interest

Compound Name: *Cecropin-B*

Cat. No.: *B1577555*

[Get Quote](#)

Subject: Troubleshooting Inconsistent MIC Results with **Cecropin-B** and Cationic Antimicrobial Peptides (AMPs) From: Dr. Alex V., Senior Application Scientist To: Research & Development Teams

Introduction: Why Your Standard MIC Protocol is Failing

If you are seeing wild fluctuations in your Minimum Inhibitory Concentration (MIC) data for **Cecropin-B**—where results shift by 4-8 fold between replicates or "disappear" entirely—you are not alone.

Cecropin-B is a cationic antimicrobial peptide (AMP). Unlike small-molecule antibiotics (e.g., ciprofloxacin), AMPs are amphipathic structures designed to interact with bacterial membranes. [1] This same feature makes them "sticky" to laboratory plasticware. Standard CLSI (Clinical and Laboratory Standards Institute) protocols for small molecules often yield false negatives for AMPs because the peptide binds to the microtiter plate before it ever reaches the bacteria.

This guide moves beyond standard protocols to the Hancock-Modified Method, the industry gold standard for AMP testing, ensuring your data reflects true biological activity, not experimental artifacts.

Part 1: The "Disappearing Peptide" Phenomenon (Adsorption)

Symptom: High MIC values (>64 µg/mL) or complete lack of inhibition in wells that should work.

Root Cause: Adsorption. **Cecropin-B** is positively charged and hydrophobic. It binds avidly to the negatively charged, hydrophobic surfaces of standard polystyrene (PS) microtiter plates.

The Fix: Material & Solvent Optimization

- Switch to Polypropylene (PP): You must use polypropylene plates or Non-Binding Surface (NBS) polystyrene. Standard tissue-culture treated plates are fatal to AMP experiments; they are designed to bind proteins.
- The BSA Block: Supplement your diluent with Bovine Serum Albumin (BSA).[2][3] BSA coats the plastic surface, occupying the hydrophobic binding sites so **Cecropin-B** remains free in solution.

Visualizing the Problem: The diagram below illustrates the kinetic competition between the plastic wall and the bacterial membrane.

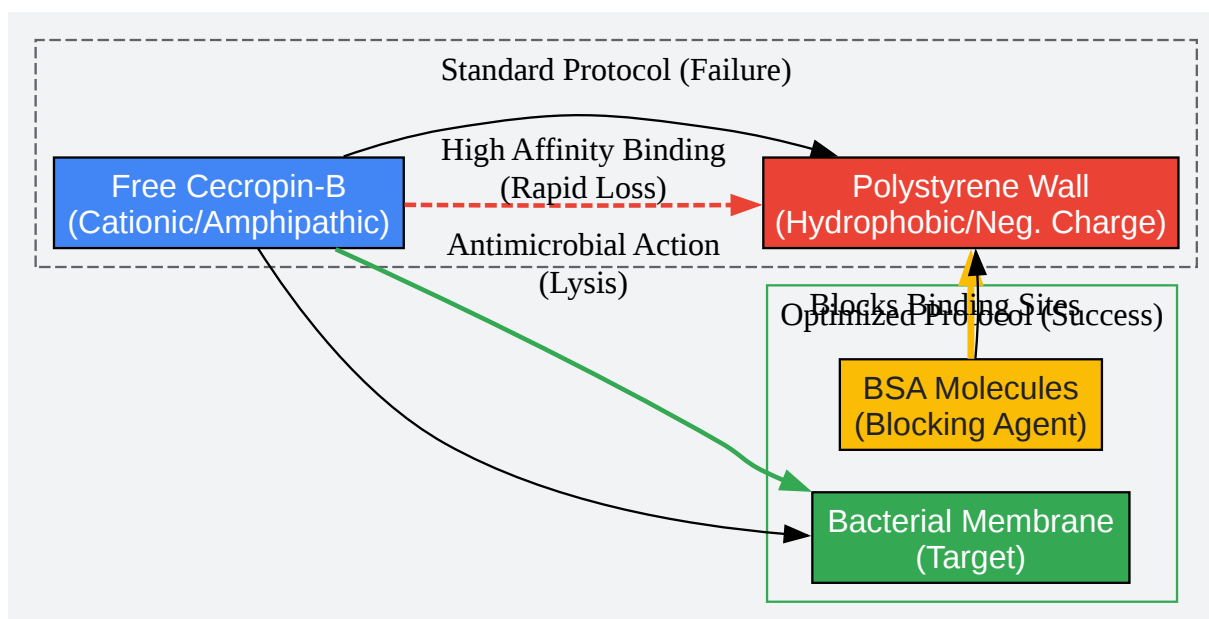

[Click to download full resolution via product page](#)

Figure 1: Kinetic competition in AMP assays. Without BSA blocking (Yellow), **Cecropin-B** (Blue) is sequestered by the plastic (Red) before it can lyse the bacteria (Green).

Part 2: The "Cation Conundrum" (Media Formulation)

Symptom: Results vary significantly between different batches of Mueller-Hinton Broth (MHB).

Root Cause: LPS Stability. **Cecropin-B** works by disrupting the outer membrane. Divalent cations (

and

) bridge the phosphate groups of Lipopolysaccharides (LPS), stabilizing the membrane and creating a barrier against AMP insertion.

The Fix: Defined Cation Control

- Standard MHB: Cation levels vary wildly by vendor.
- Cation-Adjusted MHB (CAMHB): Standard for antibiotics, but high physiological levels of cations can artificially protect bacteria from AMPs.
- Recommendation: Use CAMHB to remain CLSI compliant, but if sensitivity is low, run a parallel control in standard MHB. Crucially, document the specific cation concentration of every batch.

Data Impact Table:

Media Type	/ Conc.[4]	Cecropin-B MIC (E. coli)	Interpretation
Standard MHB	Variable (Low)	1 - 4 µg/mL	High Sensitivity (Unstable Membrane)
CAMHB (CLSI)	~12.5 mg/L / ~25 mg/L	8 - 32 µg/mL	Physiologically Relevant
High Cation	>50 mg/L	>64 µg/mL	False Resistance (Artificially Rigid Membrane)

Part 3: The Hancock-Modified Protocol (Step-by-Step)

This protocol is adapted from the Hancock Laboratory methods and Wiegand et al., specifically optimized for cationic peptides.[3]

Reagents:

- Stock Solvent: 0.01% Acetic Acid + 0.2% BSA (Sterile filtered).[3] Why? Acetic acid prevents peptide aggregation; BSA prevents adsorption.
- Media: Cation-Adjusted Mueller-Hinton Broth (CAMHB).
- Plate: 96-well Polypropylene (PP) microtiter plate.[2][5]

Workflow:

- Peptide Preparation (10x Stock):
 - Dissolve lyophilized **Cecropin-B** in sterile water to 20x the desired final concentration.
 - Dilute 1:1 with 0.02% Acetic Acid / 0.4% BSA.[2]
 - Result: 10x peptide in 0.01% Acetic Acid / 0.2% BSA.[2]
- Dilution Series:
 - Add 100 μ L of 0.01% Acetic Acid / 0.2% BSA to columns 2-10 of the PP plate.
 - Add 100 μ L of 10x Peptide to column 1.
 - Perform serial 2-fold dilutions (transfer 100 μ L) from col 1 to 10. Discard final 100 μ L.
 - Critical: Do NOT dilute in broth yet. Dilute in the BSA/Acid solvent.
- Bacterial Inoculum:
 - Adjust overnight culture to

CFU/mL in CAMHB.

- Note: The "Inoculum Effect" is severe for AMPs. Use a spectrophotometer and verify with colony counts.
- Assay Assembly:
 - Add 10 μ L of the 10x Peptide dilutions (from step 2) into a fresh PP plate containing 90 μ L of bacterial inoculum.
 - Final Concentration: 1x Peptide, 0.001% Acetic Acid, 0.02% BSA.
- Incubation:
 - 37°C for 18-24 hours.[\[2\]](#)
 - Troubleshooting: If you see regrowth at 24h due to proteases, read at 16h.

Part 4: Troubleshooting FAQ

Q: My peptide precipitates when I add it to the broth. A: This is a salt-out effect. Ensure you dissolve the peptide in water/acetic acid first (Step 1 above). Never dissolve cationic peptides directly in high-salt media like PBS or concentrated MHB.

Q: Can I use DMSO as a solvent? A: Avoid if possible. DMSO can affect membrane permeability, confounding AMP data. 0.01% Acetic Acid is the preferred solvent for Cecropins.

Q: The bacteria grew back after 24 hours. Is it resistant? A: Likely not. Bacteria release proteases (e.g., OmpT in E. coli) that degrade linear peptides like **Cecropin-B** over time.

- Action: Read MICs at 16-18 hours.
- Action: Check for the "Eagle Effect" (paradoxical growth at high concentrations) which can indicate precipitation.

Q: Why are my MICs higher than the literature? A: Check your CFU count. If you inoculated instead of

CFU/mL, the peptide-to-bacteria ratio drops, and the peptide is "soaked up" by the excess biomass before it can kill.

Summary Workflow Diagram

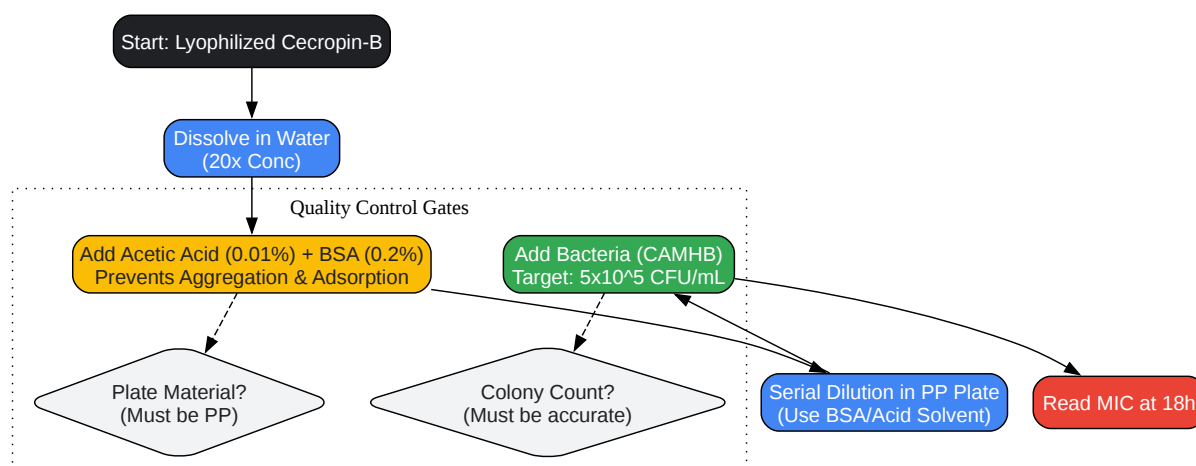

[Click to download full resolution via product page](#)

Figure 2: Optimized AMP Susceptibility Testing Workflow. Note the critical stabilization step using BSA and Acetic Acid.

References

- Wiegand, I., Hilpert, K. & Hancock, R.E.W. (2008).[3][4] Agar and broth dilution methods to determine the minimal inhibitory concentration (MIC) of antimicrobial substances.[4][5][6][7][8][9] Nature Protocols, 3, 163–175.
- Clinical and Laboratory Standards Institute (CLSI). (2015). M07-A10: Methods for Dilution Antimicrobial Susceptibility Tests for Bacteria That Grow Aerobically.
- Giacometti, A., et al. (2000).[3][5] In Vitro Susceptibility Tests for Cationic Peptides: Comparison of Broth Microdilution Methods for Bacteria That Grow Aerobically. Antimicrobial

Agents and Chemotherapy, 44(6), 1694–1696.[5]

- Hancock Laboratory. (n.d.).[10] Modified MIC Method for Cationic Antimicrobial Peptides. University of British Columbia.

Need Custom Synthesis?

BenchChem offers custom synthesis for rare earth carbides and specific isotopic labeling.

Email: info@benchchem.com or [Request Quote Online](#).

Sources

- 1. Antimicrobial peptide cecropin B functions in pathogen resistance of *Mythimna separata* | Bulletin of Entomological Research | Cambridge Core [[cambridge.org](https://www.cambridge.org)]
- 2. Modified MIC Method for Cationic Antimicrobial Peptides - Hancock Lab [cmdr.ubc.ca]
- 3. Antimicrobial Susceptibility Testing of Antimicrobial Peptides to Better Predict Efficacy - PMC [pubmed.ncbi.nlm.nih.gov]
- 4. [semanticscholar.org](https://www.semanticscholar.org) [[semanticscholar.org](https://www.semanticscholar.org)]
- 5. journals.asm.org [journals.asm.org]
- 6. scilit.com [scilit.com]
- 7. research.sahmri.org.au [research.sahmri.org.au]
- 8. Agar and broth dilution methods to determine the minimal inhibitory concentration (MIC) of antimicrobial substances | Springer Nature Experiments [experiments.springernature.com]
- 9. Agar and broth dilution methods to determine the minimal inhibitory concentration (MIC) of antimicrobial substances - PubMed [pubmed.ncbi.nlm.nih.gov]
- 10. [researchgate.net](https://www.researchgate.net) [[researchgate.net](https://www.researchgate.net)]
- To cite this document: BenchChem. [Technical Support Center: Cecropin-B Antimicrobial Susceptibility Testing (AST)]. BenchChem, [2026]. [Online PDF]. Available at: [<https://www.benchchem.com/product/b1577555/docs#technical-support-center-cecropin-b-antimicrobial-susceptibility-testing-ast>]

Disclaimer & Data Validity:

The information provided in this document is for Research Use Only (RUO) and is strictly not intended for diagnostic or therapeutic procedures. While BenchChem strives to provide accurate protocols, we make no warranties, express or implied, regarding the fitness of this product for every specific experimental setup.

Technical Support: The protocols provided are for reference purposes. Unsure if this reagent suits your experiment?

Need Industrial/Bulk Grade? [Request Custom Synthesis Quote](#)

BenchChem

Our mission is to be the trusted global source of essential and advanced chemicals, empowering scientists and researchers to drive progress in science and industry.

Contact

Address: 3281 E Guasti Rd
Ontario, CA 91761, United States
Phone: (601) 213-4426
Email: info@benchchem.com

[Contact our Ph.D. Support Team for a compatibility check](#)