

# Validating HDAC6 (HD6) Protein Interactions: A Comparative Guide

**Author:** BenchChem Technical Support Team. **Date:** May 2026

## Compound of Interest

Compound Name: Human Alpha-Defensin-6

Cat. No.: B1576414

[Get Quote](#)

## Disambiguation Note

While "HD6" is the standard gene symbol for Human Defensin 6 (DEFA6), it is also a widely recognized alias and database identifier for Histone Deacetylase 6 (HDAC6) (e.g., GeneCards GC0XP047463). Given the context of "protein interaction validation" in drug development—where HDAC6 is a critical target for cancer and neurodegeneration—this guide focuses on HDAC6. If your target is the antimicrobial peptide Defensin 6, please refer to specific literature on peptide nanonet self-assembly.

## Executive Summary

Histone Deacetylase 6 (HDAC6) is a unique cytoplasmic deacetylase characterized by two catalytic domains and a C-terminal Zinc Finger Ubiquitin-Binding Domain (ZnF-UBP).[1] Its interactome is vast, bridging the ubiquitin-proteasome system (UPS) and the autophagy machinery (aggresomes). Validating these interactions is notoriously difficult due to the transient nature of ubiquitin binding and the tendency of HDAC6 to aggregate in non-native lysates.

This guide compares the three primary methodologies for validating HDAC6 interactions: Traditional Co-Immunoprecipitation (Co-IP), Ubiquitin-Trap Pull-downs (TUBE), and Proximity

Labeling (BioID). We evaluate commercial solutions based on specificity, yield, and background noise to assist in experimental design.

## The HDAC6 Interaction Landscape

Understanding the structural basis of HDAC6 interactions is prerequisite to selecting the right assay. HDAC6 does not merely "bind" proteins; it acts as a mechanical bridge.

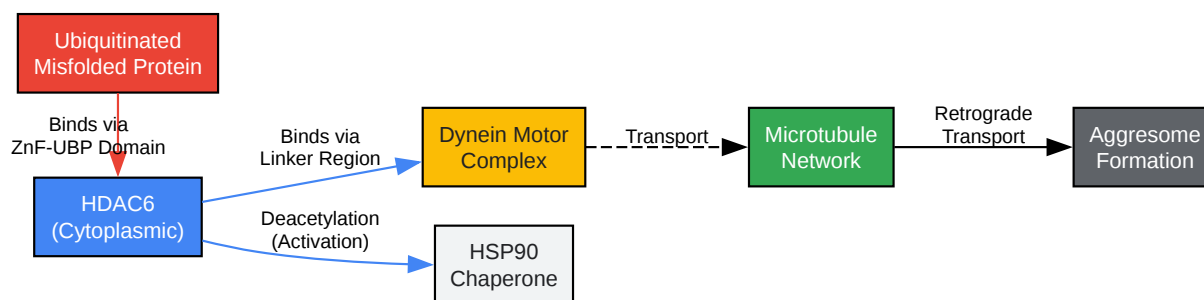

[Click to download full resolution via product page](#)

Figure 1: The HDAC6 Bridging Mechanism.[1][2][3] HDAC6 connects ubiquitinated cargo to the dynein motor for transport to the aggresome, a critical pathway in neurodegeneration research.

## Comparative Analysis of Pull-Down Methodologies

### Method A: Antibody-Based Co-Immunoprecipitation (Co-IP)

The Gold Standard for stable complexes (e.g., HDAC6-Dynein).

Mechanism: An anti-HDAC6 antibody is immobilized on Protein A/G beads to capture the complex from cell lysate. Challenge: HDAC6 is 131 kDa. If you use a standard antibody for IP and Western Blot, the heavy chain (~50 kDa) often obscures key interactors like Tubulin (50 kDa) or Ubiquitin chains.

### Product Comparison: Capture Matrices

Feature	Magnetic Beads (e.g., Thermo Dynabeads)	Agarose/Sepharose Slurry (e.g., Santa Cruz)	Nanobody Traps (e.g., ChromoTek)
Binding Kinetics	Fast (30 min). Ideal for transient interactions.	Slow (2-4 hrs). Porous structure requires diffusion.	Instant. High affinity ( ).
Background	Low.[4] Smooth surface reduces non-specific binding.	High. Porous matrix traps contaminants.	Ultra-Low.[5] No heavy/light chain contamination.
HDAC6 Suitability	High. Recommended for ubiquitinated cargo preservation.	Medium. Risk of losing ubiquitin chains during long washes.	Best (if GFP-tagged).
Cost	\$	\$	\$

Recommendation: For endogenous HDAC6, use Magnetic Beads cross-linked to a Rabbit Monoclonal Antibody (e.g., Abcam EPR22951 or CST D2E5). Rabbit mAbs offer higher affinity than mouse mAbs, crucial for pulling down the large HDAC6 complex.

## Method B: Tandem Ubiquitin Binding Entities (TUBE)

The Specialist for Ubiquitin-Dependent Interactions.

Mechanism: Instead of targeting HDAC6, you use engineered high-affinity ubiquitin traps to pull down all ubiquitinated proteins. You then blot for HDAC6 to see if it is associated. Why use this? HDAC6's ZnF-UBP domain binds ubiquitin non-covalently. Standard Co-IP washes often strip this interaction. TUBEs protect the ubiquitin chains from deubiquitinases (DUBs) and maintain the complex.

### Product Spotlight: LifeSensors TUBE 2 vs. Agarose-Ub

Product	Specificity	Binding Capacity	Verdict
LifeSensors TUBE 2	Binds Poly-Ub (K48/K63) with nM affinity.	High. Protects against DUBs.	Essential for proving HDAC6 binds ubiquitinated cargo.[2] [6]
Standard Agarose-Ub	Low affinity; relies on avidity.	Moderate.	Obsolete for interaction validation.

## Method C: Proximity Labeling (BioID/TurboID)

The Modern Solution for Transient Interactions.

Mechanism: Fuse HDAC6 to a biotin ligase (TurboID). It biotinylates proteins within 10nm. Streptavidin pull-down recovers the interactome. Advantage: Captures "kiss-and-run" interactions (e.g., enzymatic deacetylation of HSP90) that fail in Co-IP.

## Step-by-Step Protocol: Magnetic Co-IP for HDAC6

This protocol is optimized for endogenous HDAC6 using magnetic beads to minimize background.

### Materials

- Lysis Buffer: 50 mM Tris-HCl (pH 7.5), 150 mM NaCl, 1% NP-40, 1 mM EDTA, 10% Glycerol.
- Inhibitors (CRITICAL):
  - Protease Inhibitor Cocktail.
  - HDAC Inhibitor: Trichostatin A (TSA) or Tubastatin A (10  $\mu$ M) to preserve acetylation status of partners.
  - DUB Inhibitor: N-Ethylmaleimide (NEM, 10 mM) if looking for ubiquitin interactions.
- Beads: Protein A/G Magnetic Beads (e.g., Dynabeads).
- Antibody: Anti-HDAC6 (Rabbit mAb recommended).

## Workflow

- Lysate Preparation:
  - Harvest  
  
cells. Wash with ice-cold PBS.
  - Lyse in 500  $\mu$ L Lysis Buffer + Inhibitors for 30 min on ice.
  - Note: Do not sonicate excessively; HDAC6 is associated with microtubules and can be mechanically sheared.
  - Centrifuge at 14,000 x g for 15 min at 4°C. Collect supernatant.
- Pre-Clearing (Optional but Recommended):
  - Incubate lysate with 20  $\mu$ L empty magnetic beads for 30 min at 4°C.
  - Remove beads (magnet). This removes sticky proteins that bind the bead surface.
- Antibody Binding:
  - Add 2-5  $\mu$ g of Anti-HDAC6 antibody to the lysate.
  - Incubate with rotation overnight at 4°C (for low abundance) or 2 hours (if overexpressed).
- Bead Capture:
  - Add 30  $\mu$ L pre-washed Magnetic Beads.
  - Incubate for 1 hour at 4°C with rotation.
- Washing (The Critical Step):
  - Place tube on magnet. Discard supernatant.
  - Wash 1-2: Low stringency (Lysis Buffer).

- Wash 3: High salt (Lysis Buffer with 300 mM NaCl) – Only if looking for strong interactors like Dynein. Skip for Ubiquitin.
- Wash 4: Detergent-free buffer (50 mM Tris, 150 mM NaCl) to remove NP-40 before elution.
- Elution:
  - Add 40  $\mu$ L 2x SDS-PAGE Sample Buffer.
  - Boil at 95°C for 5 min.
  - Magnetically separate and load supernatant onto gel.

## Data Presentation & Interpretation

When publishing, present your data using the following structure to ensure "Self-Validating" logic.

### Experimental Controls Checklist

Lane	Component	Expected Result	Interpretation
Input (5%)	Whole Lysate	Bands for HDAC6 + Interactor	Confirms expression of both proteins.
IgG Control	Lysate + Non-specific IgG	NO BANDS	Proves interaction is not non-specific bead binding.
IP: HDAC6	Lysate + Anti-HDAC6	Band for HDAC6 (Bait)	Confirms IP efficiency (Catch).
Co-IP	Lysate + Anti-HDAC6	Band for Interactor (Prey)	The Result. Proves physical interaction.
$\Delta$ ZnF Mutant	HDAC6- $\Delta$ ZnF Lysate	No Ubiquitin Smear	Specificity Control. Proves Ub-binding requires the ZnF domain.

## Visualizing the Workflow

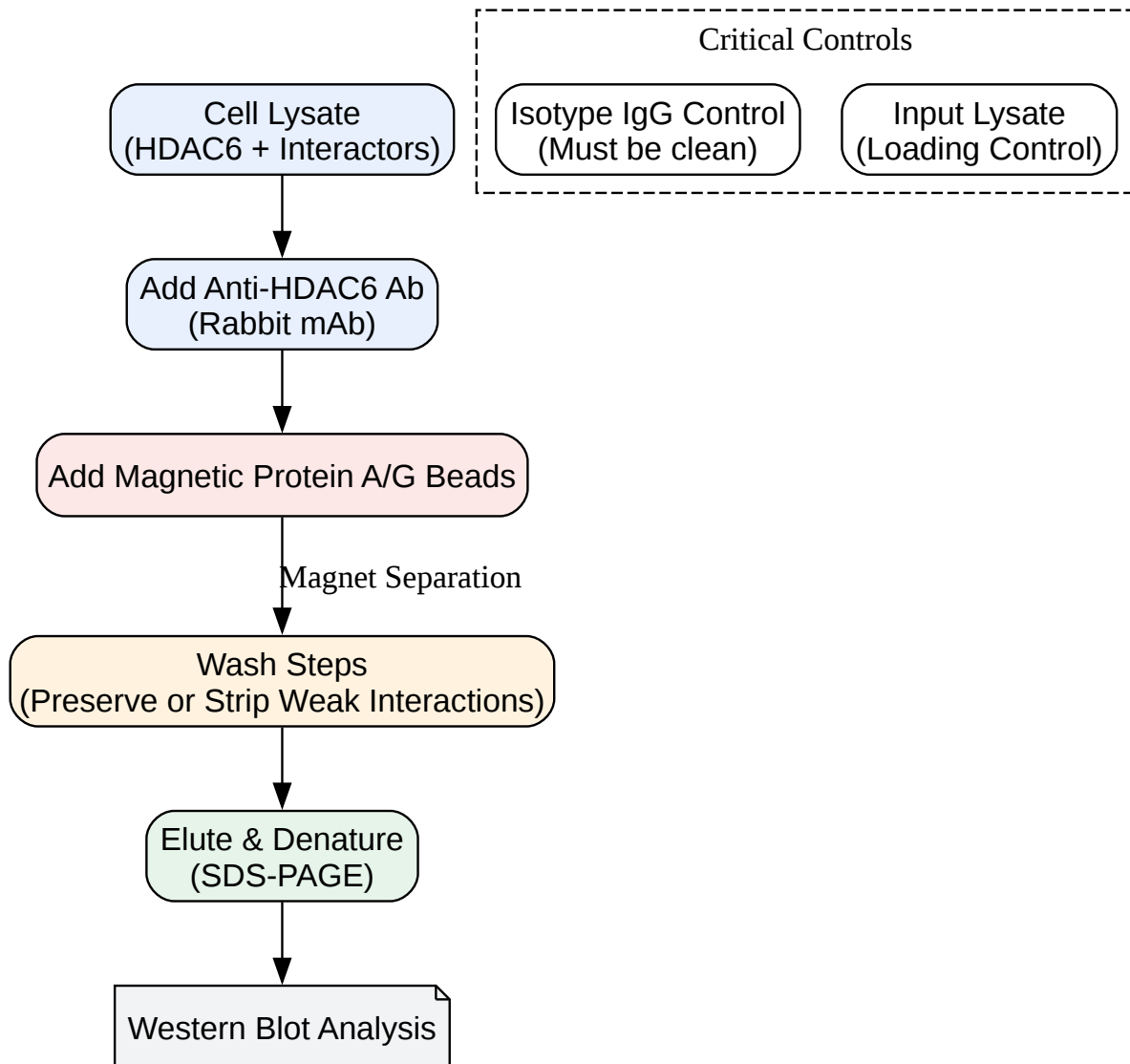

[Click to download full resolution via product page](#)

Figure 2: Optimized Magnetic Bead Co-IP Workflow for HDAC6.

## References

- Boyault, C., et al. (2007). [6] HDAC6 controls major cell response pathways to cytotoxic accumulation of protein aggregates. [2] Genes & Development. [Link](#)

- Seigneurin-Berny, D., et al. (2001).[6] Identification of components of the murine histone deacetylase 6 complex: link between acetylation and ubiquitination signaling pathways. *Molecular and Cellular Biology*. [Link](#)
- Hjerpe, R., et al. (2009). Efficient protection and isolation of ubiquitylated proteins using tandem ubiquitin-binding entities. *EMBO Reports*. [Link](#)
- Abcam. Anti-HDAC6 antibody [EPR22951-29] Product Datasheet. [Link](#)
- Thermo Fisher Scientific. Dynabeads™ Protein G for Immunoprecipitation. [Link](#)

### *Need Custom Synthesis?*

*BenchChem offers custom synthesis for rare earth carbides and specific isotopic labeling.*

*Email: [info@benchchem.com](mailto:info@benchchem.com) or [Request Quote Online](#).*

## Sources

- 1. Methods for addressing the protein-protein interaction between histone deacetylase 6 and ubiquitin | bioRxiv [[biorxiv.org](https://www.biorxiv.org)]
- 2. [mdpi.com](https://www.mdpi.com) [[mdpi.com](https://www.mdpi.com)]
- 3. [researchgate.net](https://www.researchgate.net) [[researchgate.net](https://www.researchgate.net)]
- 4. [mdpi.com](https://www.mdpi.com) [[mdpi.com](https://www.mdpi.com)]
- 5. HDAC6 ELISA kit [[antibodies-online.com](https://www.antibodies-online.com)]
- 6. HDAC6–ubiquitin interaction controls the duration of HSF1 activation after heat shock - PMC [[pmc.ncbi.nlm.nih.gov](https://pubmed.ncbi.nlm.nih.gov)]
- To cite this document: BenchChem. [Validating HDAC6 (HD6) Protein Interactions: A Comparative Guide]. BenchChem, [2026]. [Online PDF]. Available at: [<https://www.benchchem.com/product/b1576414/docs#validating-hdac6-hd6-protein-interactions-a-comparative-guide>]

---

### Disclaimer & Data Validity:

The information provided in this document is for Research Use Only (RUO) and is strictly not intended for diagnostic or therapeutic procedures. While BenchChem strives to provide accurate protocols, we make no warranties, express or implied, regarding the fitness of this product for every specific experimental setup.

**Technical Support:** The protocols provided are for reference purposes. Unsure if this reagent suits your experiment?

**Need Industrial/Bulk Grade?** [Request Custom Synthesis Quote](#)

## BenchChem

Our mission is to be the trusted global source of essential and advanced chemicals, empowering scientists and researchers to drive progress in science and industry.

### Contact

Address: 3281 E Guasti Rd  
Ontario, CA 91761, United States  
Phone: (601) 213-4426  
Email: [info@benchchem.com](mailto:info@benchchem.com)

[Contact our Ph.D. Support Team for a compatibility check](#)