

Regulation of LGALS13 Gene Expression in Pregnancy: A Technical Guide

Author: BenchChem Technical Support Team. **Date:** April 2026

Compound of Interest

Compound Name: PP13
Cat. No.: B1576774

[Get Quote](#)

For Researchers, Scientists, and Drug Development Professionals

Introduction

Galectin-13 (LGALS13), also known as Placental Protein 13 (**PP13**), is a key protein in primate pregnancy, playing crucial roles in placentation, maternal immune tolerance, and vascular remodeling.[1][2] Predominantly expressed by the syncytiotrophoblast, the expression of the LGALS13 gene is tightly regulated throughout gestation.[2][3] Dysregulation of LGALS13 expression is strongly associated with adverse pregnancy outcomes, most notably preeclampsia, making it a critical area of investigation for diagnostics and therapeutics.[3][4][5] This technical guide provides an in-depth overview of the molecular mechanisms governing LGALS13 gene expression during pregnancy, with a focus on transcriptional control, signaling pathways, and relevant experimental methodologies.

Data Presentation: Quantitative Analysis of LGALS13 Expression

The expression of LGALS13 is significantly altered in pregnancies complicated by preeclampsia. The following tables summarize key quantitative findings from comparative

studies.

Table 1: LGALS13 mRNA Expression in Placental Tissue

Condition	Fold Change vs. Control	Gestational Age	Method	Reference
Preterm Preeclampsia	3.5-fold lower	Third Trimester	RT-qPCR	[1][6]
Preterm Preeclampsia	Decreased	First Trimester (11 weeks)	Laser Capture Microdissection & RT-qPCR	[3]
Preeclampsia & HELLP Syndrome	3.5-fold lower	Term	RT-qPCR	[2]
Normal Pregnancy	Decreases with advancing gestational age	Second to Third Trimester	RT-qPCR	[4][6]

Table 2: Placental Protein 13 (**PP13**) Concentration

Condition	Sample Type	Change vs. Control	Gestational Age	Method	Reference
Preterm Preeclampsia	Maternal Serum	Significantly higher	Third Trimester	ELISA	[4]
Preterm HELLP Syndrome	Maternal Serum	Significantly higher	Third Trimester	ELISA	[4]
Preterm Preeclampsia	Placental Tissue	Decreased	Third Trimester	ELISA/Western Blot	[4]
Term Preeclampsia	Maternal Serum	No significant difference	Term	ELISA	[4]
Normal Pregnancy	Maternal Serum	Increases with advancing gestational age	Third Trimester	ELISA	[4]
Women who later develop preeclampsia	Maternal Serum	Lower levels	First Trimester	ELISA	[3]

Table 3: Effect of -98A/C Promoter Polymorphism on LGALS13 Promoter Activity

Genotype	Cell Type	Condition	Change in Luciferase Activity vs. -98C	Method	Reference
-98A	BeWo cells	Non-differentiated	13% lower expression	Luciferase Reporter Assay	[7]
-98A	BeWo cells	Forskolin-differentiated (48h)	26% lower expression	Luciferase Reporter Assay	[7]

Signaling Pathways and Regulatory Mechanisms

The expression of LGALS13 is governed by a network of transcription factors and signaling pathways that are integral to placental development and function.

Transcriptional Regulation

Several key transcription factors have been identified to regulate LGALS13 expression in trophoblasts:

- **Transcription Factor AP-2 Alpha (TFAP2A):** This transcription factor is crucial for the expression of numerous placental genes. A TFAP2A binding site has been identified in the promoter region of LGALS13 at positions -101 to -93.[7] The common -98A/C single nucleotide polymorphism (SNP) is located within this binding site. The 'C' allele exhibits a higher binding affinity for TFAP2A compared to the 'A' allele, leading to higher transcriptional activity.[7] The A/A genotype is associated with reduced LGALS13 expression and an increased risk for developing preeclampsia.[1]
- **Glial Cells Missing-1 (GCM1) and Estrogen-Related Receptor Gamma (ESRRG):** GCM1 is a master regulator of trophoblast fusion and syncytialization.[8] It indirectly promotes LGALS13 expression by upregulating other key trophoblastic transcription factors, including ESRRG.[3] In severe preterm preeclampsia, the placental expression of both GCM1 and ESRRG is decreased, leading to a subsequent downregulation of LGALS13.[3][5]
- **cAMP/PKA Signaling Pathway:** The differentiation of cytotrophoblasts into a syncytiotrophoblast is a critical process for a healthy placenta and is driven by the cyclic adenosine monophosphate (cAMP) and protein kinase A (PKA) signaling pathway.[3] This differentiation process is tightly linked to an increase in LGALS13 expression.[2][3] In vitro, induction of syncytialization in BeWo choriocarcinoma cells using the cAMP analog forskolin leads to a significant upregulation of LGALS13 expression.[3][9] This effect can be blocked by a PKA inhibitor, confirming the pathway's role.[3][9]

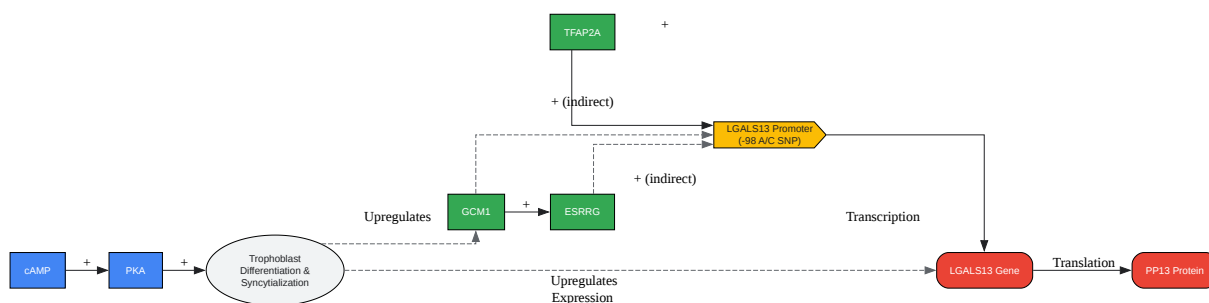

[Click to download full resolution via product page](#)

Transcriptional control of LGALS13 expression in trophoblasts.

Epigenetic Regulation

DNA methylation is another layer of regulation for LGALS13. Studies have shown that differential methylation of the LGALS13 gene occurs in the villous trophoblast in preterm preeclampsia, which may interfere with its expression.[3] This suggests that epigenetic modifications contribute to the pathological downregulation of LGALS13 in this disorder.

Post-Translational Signaling by PP13 Protein

Once expressed and secreted, the **PP13** protein itself activates signaling pathways that are crucial for maternal vascular adaptation to pregnancy. **PP13** induces vasodilation of uterine arteries, a process mediated by the endothelium.[1][10]

- eNOS and Prostaglandin Pathways: Pharmacological analyses have revealed that **PP13**-induced vasodilation is dependent on the activation of endothelial nitric oxide synthase (eNOS) and the cyclooxygenase (COX)-prostaglandin pathways.[1][10] **PP13** stimulates the

production of nitric oxide (NO) and prostaglandins (likely PGE₂), which in turn act on the vascular smooth muscle cells to cause relaxation.[1]

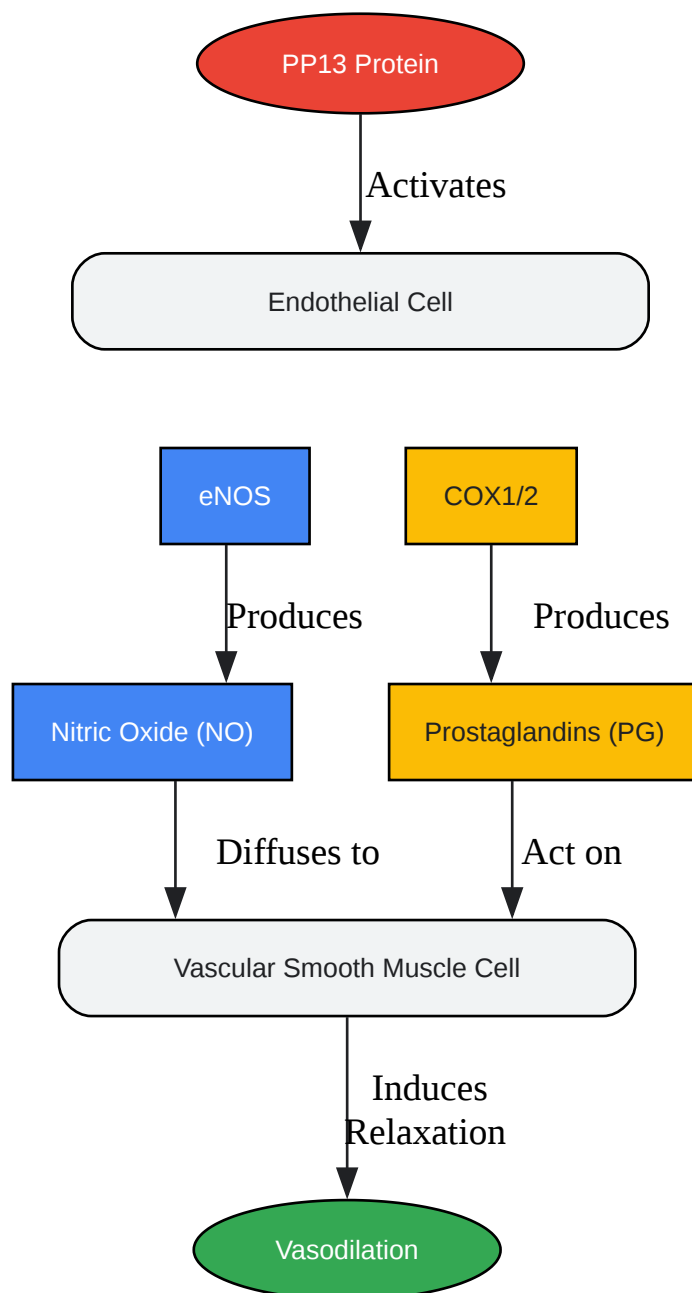

[Click to download full resolution via product page](#)

PP13-induced vasodilation signaling pathway.

Experimental Protocols

Detailed methodologies are essential for the accurate study of LGALS13 gene regulation. Below are protocols for key experiments cited in the literature.

Cell Culture and Trophoblast Differentiation Model

The BeWo choriocarcinoma cell line is a widely used in-vitro model to study trophoblast differentiation and LGALS13 expression.

- Cell Line: BeWo (clone b30)
- Culture Medium: Ham's F-12K Medium supplemented with 10% Fetal Bovine Serum (FBS) and 1% Penicillin-Streptomycin.
- Culture Conditions: 37°C, 5% CO₂ in a humidified incubator.
- Induction of Differentiation (Syncytialization):
 - Plate BeWo cells to achieve 60-70% confluency.
 - Replace the culture medium with fresh medium containing a cAMP-inducing agent. Forskolin is commonly used at a concentration of 20-50 μM.[9][11] An alternative is 8-Bromo-cAMP at 250 μM.[12]
 - Incubate the cells for 48 to 72 hours to allow for the formation of multinucleated syncytia. [9][11][12]
 - Confirm differentiation by observing cell fusion morphologically (e.g., via phalloidin staining of actin filaments) and by measuring the expression of syncytialization markers like human chorionic gonadotropin (hCG).[9][12]
- Inhibition of Differentiation: To confirm the role of the PKA pathway, cells can be co-treated with Forskolin and a PKA inhibitor, such as H-89 (10 μM).[9][13]

Quantitative Real-Time RT-PCR (RT-qPCR) for LGALS13 mRNA

This protocol is used to quantify the relative expression levels of LGALS13 mRNA in placental tissue or cultured cells.

- RNA Isolation: Extract total RNA from placental tissue homogenates or cultured BeWo cells using a commercial kit (e.g., RNeasy Kit, Qiagen) according to the manufacturer's instructions. Treat with DNase I to remove any contaminating genomic DNA.[4]
- cDNA Synthesis: Synthesize first-strand cDNA from 0.5-1.0 µg of total RNA using a reverse transcription kit (e.g., First Strand cDNA Synthesis Kit, Roche) with oligo(dT) or random hexamer primers.[4]
- qPCR Reaction:
 - Prepare a reaction mix containing cDNA template, forward and reverse primers for LGALS13, and a suitable qPCR master mix (e.g., SYBR Green or TaqMan).
 - Primer Sequences:
 - LGALS13 Forward: 5'-GCAAACAATTTGAGCTGTG-3'[4]
 - LGALS13 Reverse: 5'-CACTGAGGTCAGGGAGA-3'[4]
 - Reference Genes: Use stably expressed reference genes for normalization, such as Hypoxanthine-guanine phosphoribosyltransferase (HPRT) or Tyrosine 3-monooxygenase/tryptophan 5-monooxygenase activation protein zeta (YWHAZ).[4]
 - HPRT Forward: 5'-GGCAGTATAATCCAAAGATGGTC-3'[4]
 - HPRT Reverse: 5'-GTCTGGCTTATATCCAACACTTG-3'[4]
 - Thermal Cycling: Perform the qPCR on a real-time PCR system with a standard cycling protocol (e.g., initial denaturation at 95°C, followed by 40 cycles of denaturation at 95°C and annealing/extension at 60°C).
- Data Analysis: Calculate the relative expression of LGALS13 using the $\Delta\Delta C_t$ method, normalizing the C_t values of LGALS13 to the geometric mean of the reference gene(s).

Promoter-Reporter Luciferase Assay

This assay is used to functionally assess the activity of the LGALS13 promoter and the effect of polymorphisms or transcription factors.

- Plasmid Construction:
 - Clone the promoter region of the LGALS13 gene (e.g., ~1 kb upstream of the transcription start site) into a promoterless luciferase reporter vector (e.g., pGL3-Basic).
 - To study polymorphisms like -98A/C, create separate constructs for each allele using site-directed mutagenesis.[7]
- Cell Transfection:
 - Seed BeWo cells in 24- or 48-well plates.
 - Co-transfect the cells with the LGALS13 promoter-luciferase construct and a control vector expressing a different reporter (e.g., Renilla luciferase driven by a constitutive promoter) for normalization of transfection efficiency. Use a standard transfection reagent like Lipofectamine 2000.
 - To assess the effect of a transcription factor, co-transfect with an expression vector for that factor (e.g., TFAP2A).
- Cell Treatment: After 24 hours, treat the cells as required (e.g., with 50 μ M Forskolin to induce differentiation).
- Luciferase Assay:
 - After 48 hours of treatment, lyse the cells.
 - Measure the firefly and Renilla luciferase activities sequentially using a dual-luciferase reporter assay system and a luminometer.
- Data Analysis: Normalize the firefly luciferase activity (from the LGALS13 promoter) to the Renilla luciferase activity. Compare the relative luciferase units (RLU) between different constructs or treatment conditions.[7]

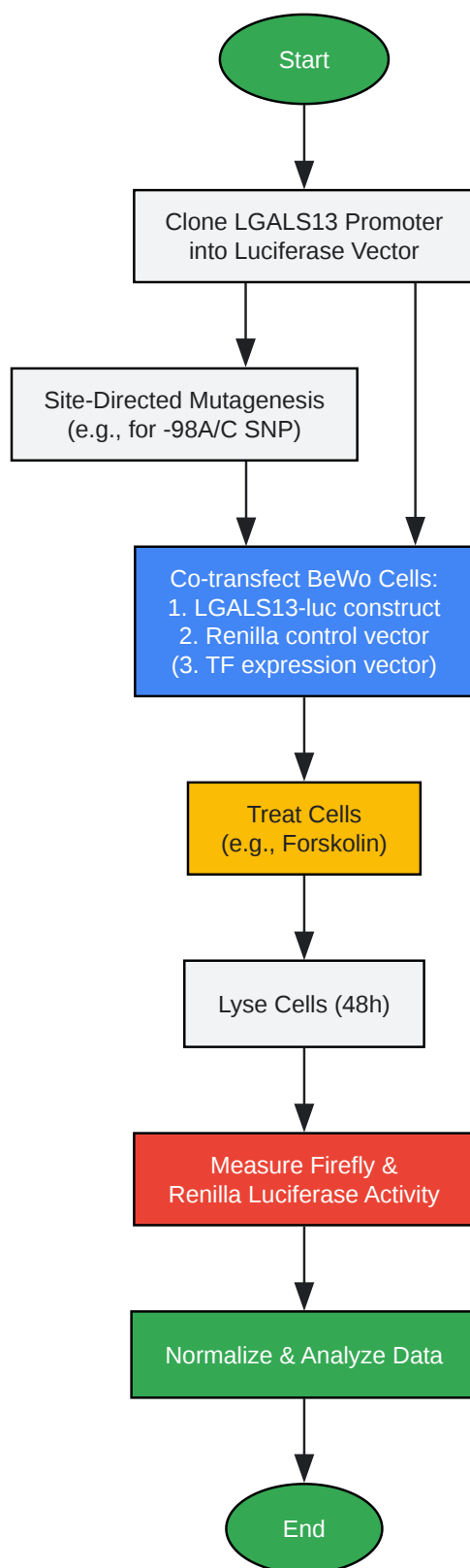

[Click to download full resolution via product page](#)

Workflow for LGALS13 promoter activity analysis.

Conclusion

The regulation of the LGALS13 gene is a complex process central to a healthy pregnancy. Its expression is intricately linked to trophoblast differentiation via the cAMP/PKA pathway and is controlled by key transcription factors such as TFAP2A, GCM1, and ESRRG. Genetic variations in the promoter region and epigenetic modifications can significantly impact its expression, with direct implications for pathologies like preeclampsia. The secreted **PP13** protein further contributes to the maternal physiological adaptations to pregnancy by promoting vasodilation through eNOS and prostaglandin signaling. A thorough understanding of these regulatory networks, facilitated by the experimental protocols outlined in this guide, is paramount for the development of novel diagnostic and therapeutic strategies to manage pregnancy complications associated with aberrant LGALS13 expression.

Need Custom Synthesis?

BenchChem offers custom synthesis for rare earth carbides and specific isotopic labeling.

Email: info@benchchem.com or [Request Quote Online](#).

References

- [1. researchgate.net \[researchgate.net\]](#)
- [2. Galectin 13 \(PP13\) Facilitates Remodeling and Structural Stabilization of Maternal Vessels during Pregnancy - PMC \[pmc.ncbi.nlm.nih.gov\]](#)
- [3. Placental Protein 13 \(PP13\) – A Placental Immunoregulatory Galectin Protecting Pregnancy - PMC \[pmc.ncbi.nlm.nih.gov\]](#)
- [4. Placental Protein 13 \(galectin-13\) has decreased placental expression but increased shedding and maternal serum concentrations in patients presenting with preterm preeclampsia and HELLP syndrome - PMC \[pmc.ncbi.nlm.nih.gov\]](#)
- [5. Placental protein 13: An important biological protein in preeclampsia - PMC \[pmc.ncbi.nlm.nih.gov\]](#)
- [6. researchgate.net \[researchgate.net\]](#)
- [7. researchgate.net \[researchgate.net\]](#)
- [8. New insights into the regulation of placental growth factor gene expression by the transcription factors GCM1 and DLX3 in human placenta - PMC \[pmc.ncbi.nlm.nih.gov\]](#)

- [9. The choriocarcinoma cell line BeWo: syncytial fusion and expression of syncytium-specific proteins - PubMed \[pubmed.ncbi.nlm.nih.gov\]](#)
- [10. tandfonline.com \[tandfonline.com\]](#)
- [11. Transcriptomic profiling of trophoblast fusion using BeWo and JEG-3 cell lines - PubMed \[pubmed.ncbi.nlm.nih.gov\]](#)
- [12. researchgate.net \[researchgate.net\]](#)
- [13. researchgate.net \[researchgate.net\]](#)
- To cite this document: BenchChem. [Regulation of LGALS13 Gene Expression in Pregnancy: A Technical Guide]. BenchChem, [2026]. [Online PDF]. Available at: [\[https://www.benchchem.com/product/b1576774/docs#regulation-of-lgals13-gene-expression-in-pregnancy-a-technical-guide\]](https://www.benchchem.com/product/b1576774/docs#regulation-of-lgals13-gene-expression-in-pregnancy-a-technical-guide)

Disclaimer & Data Validity:

The information provided in this document is for Research Use Only (RUO) and is strictly not intended for diagnostic or therapeutic procedures. While BenchChem strives to provide accurate protocols, we make no warranties, express or implied, regarding the fitness of this product for every specific experimental setup.

Technical Support: The protocols provided are for reference purposes. Unsure if this reagent suits your experiment?

Need Industrial/Bulk Grade? [Request Custom Synthesis Quote](#)

BenchChem

Our mission is to be the trusted global source of essential and advanced chemicals, empowering scientists and researchers to drive progress in science and industry.

Contact

Address: 3281 E Guasti Rd
Ontario, CA 91761, United States
Phone: (601) 213-4426
Email: info@benchchem.com

Contact our Ph.D. Support Team for a compatibility check