

Cross-Species Comparison of Alpha-Defensin 5 Function: A Guide for Researchers

Author: BenchChem Technical Support Team. **Date:** April 2026

Compound of Interest

Compound Name: Human Defensin-5

Cat. No.: B1576409

[Get Quote](#)

For Immediate Release

This guide provides a comprehensive cross-species comparison of the function of alpha-defensin 5 (DEFA5), a critical component of the innate immune system. Primarily expressed by Paneth cells in the small intestine, DEFA5 plays a vital role in host defense and maintenance of gut homeostasis. This document summarizes key quantitative data, details experimental protocols, and visualizes relevant signaling pathways to aid researchers, scientists, and drug development professionals in their understanding of this important antimicrobial peptide.

Data Presentation: Antimicrobial Activity

Human alpha-defensin 5 (HD-5) and its murine orthologs, the cryptidins (e.g., cryptdin-4), exhibit broad-spectrum antimicrobial activity against a range of pathogens. The following tables summarize the bactericidal potency of these defensins from various studies.

Table 1: Antimicrobial Activity of Human Alpha-Defensin 5 (HD-5)

Target Microorganism	Assay Type	Potency Metric (Concentration)	Reference
Escherichia coli	Virtual Colony Count	vLD99: >50 μ M	[1]
Staphylococcus aureus	Virtual Colony Count	vLD99: ~12.5 μ M	[1]
Bacillus cereus	Turbidimetric Assay	vLD99.9: <8 μ g/mL	[2][3]
Enterobacter aerogenes	Turbidimetric Assay	vLD99: ~16 μ g/mL	[4]
Listeria monocytogenes	Not Specified	Bactericidal	[5]
Salmonella typhimurium	Not Specified	Bactericidal	[5]
Candida albicans	Not Specified	Fungicidal	[5]

Table 2: Antimicrobial Activity of Mouse Cryptdin-4 (Crp4)

Target Microorganism	Assay Type	Potency Metric (Concentration)	Reference
Escherichia coli	Radial Diffusion Assay	~30x more active than NP-1	[6]
Escherichia coli	Bactericidal Assay	Active at 10 μ g/mL	[6]
Staphylococcus aureus	Not Specified	Bactericidal	[7]
Noncommensal Bacteria	Bactericidal Assay	Potent activity	[8]
Commensal Bacteria	Bactericidal Assay	Minimal or no activity (oxidized form)	[8]

Experimental Protocols

The following are detailed methodologies for key experiments cited in the comparison of alpha-defensin 5 function.

Virtual Colony Count (VCC) Assay

This method provides a quantitative measure of bactericidal activity.

- Bacterial Preparation:
 - Inoculate a bacterial strain into a suitable broth medium (e.g., Mueller Hinton Broth).
 - Grow the culture overnight at 37°C with shaking.
 - Dilute the overnight culture into fresh broth and grow to mid-logarithmic phase (OD600 of 0.5-0.7).
 - Pellet the bacteria by centrifugation, wash with a low-salt buffer (e.g., 10 mM sodium phosphate, pH 7.4), and resuspend in the same buffer to a concentration of approximately $1-2 \times 10^6$ colony-forming units (CFU)/mL.[2]
- Assay Procedure:
 - Prepare serial dilutions of the defensin peptide in the low-salt buffer.
 - In a 96-well polypropylene microtiter plate, mix 50 μ L of the bacterial suspension with 50 μ L of the defensin dilutions.[2]
 - Incubate the plate at 37°C for a defined period (e.g., 2 hours).
 - Following incubation, add a rich broth medium to each well to support the growth of surviving bacteria.
 - Monitor bacterial growth over time by measuring the optical density at 650 nm (OD650) using a microplate reader.
- Data Analysis:

- The time it takes for the OD650 to cross a set threshold is determined for each defensin concentration.
- A calibration curve is generated by plotting the threshold times against the initial number of viable bacteria (determined by standard plate counts).
- The number of surviving bacteria in each defensin-treated well is calculated from the calibration curve.
- Virtual Lethal Doses (vLD), such as vLD50, vLD90, and vLD99, are determined as the defensin concentrations that result in 50%, 90%, and 99% killing, respectively.[2][3]

Radial Diffusion Assay (RDA)

This gel-based assay determines the antimicrobial activity of peptides by observing zones of growth inhibition.

- Preparation of Assay Plates:
 - Prepare a sterile underlay agarose gel consisting of a low-salt buffer (e.g., 10 mM sodium phosphate, pH 7.4), a low concentration of tryptic soy broth (TSB), and agarose.
 - Cool the molten agarose to ~45°C and add a suspension of mid-logarithmic phase bacteria to a final concentration of approximately 4×10^6 CFU/mL.[9]
 - Pour the mixture into a petri dish and allow it to solidify.
 - Create small wells (e.g., 1-3 mm in diameter) in the solidified agar.[9]
- Assay Procedure:
 - Add a small volume (e.g., 2-10 μ L) of the defensin solution at a known concentration into each well.[9][10]
 - Incubate the plate at 37°C for a few hours (e.g., 3 hours) to allow the peptide to diffuse into the agar.[9]

- Pour an overlay gel of molten, nutrient-rich agar (e.g., 6% TSB) over the plate and allow it to solidify.
- Incubate the plate overnight at 37°C.
- Data Analysis:
 - Measure the diameter of the clear zone of bacterial growth inhibition around each well.
 - The diameter of the clearance zone is proportional to the antimicrobial activity of the peptide. A standard curve can be generated using known concentrations of a reference antimicrobial peptide.

Mandatory Visualization

Signaling Pathways and Experimental Workflows

The following diagrams, created using the DOT language, illustrate key signaling pathways and experimental workflows related to alpha-defensin 5 function.

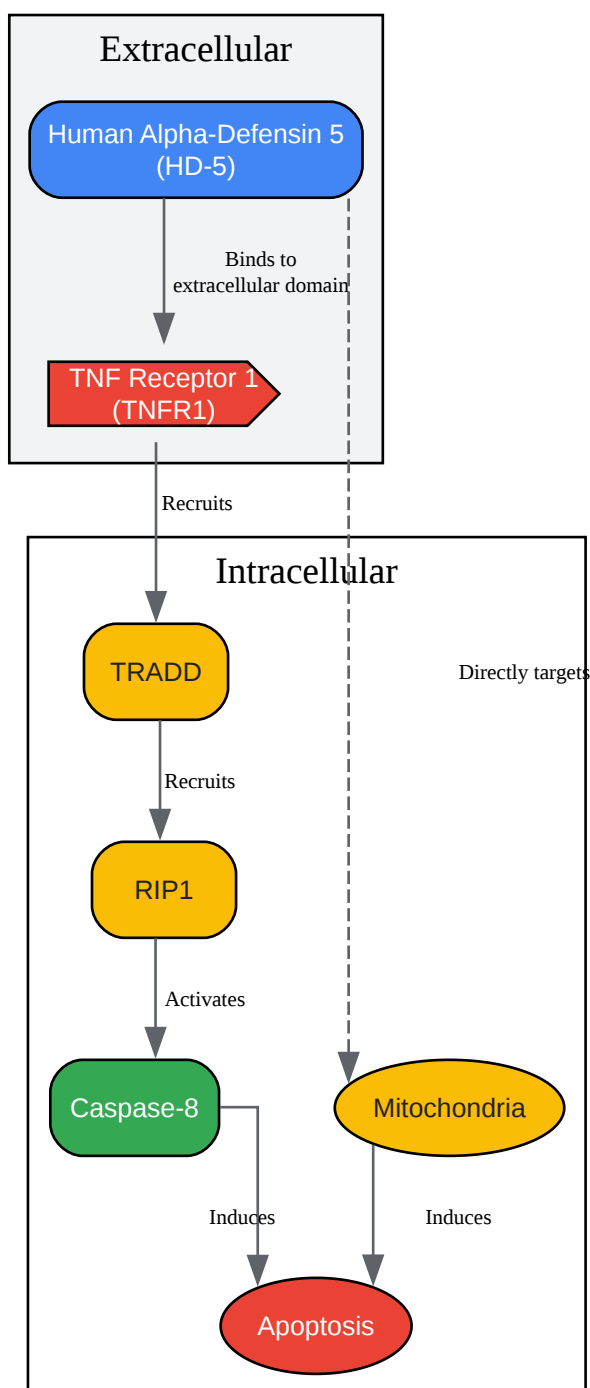

[Click to download full resolution via product page](#)

HD-5 Interaction with the TNF Receptor Pathway.

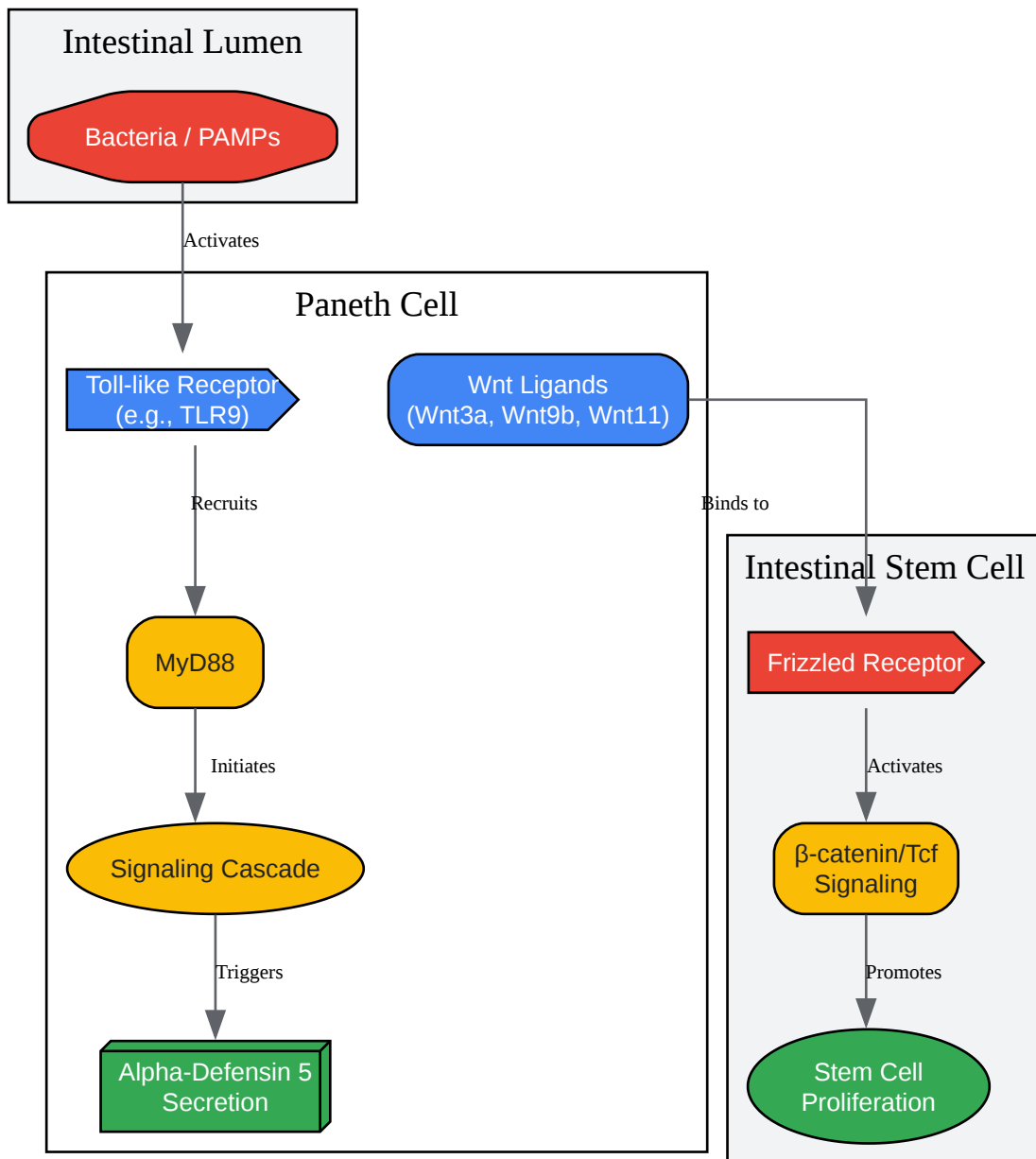

[Click to download full resolution via product page](#)

Paneth Cell Signaling and DEFA5 Secretion.

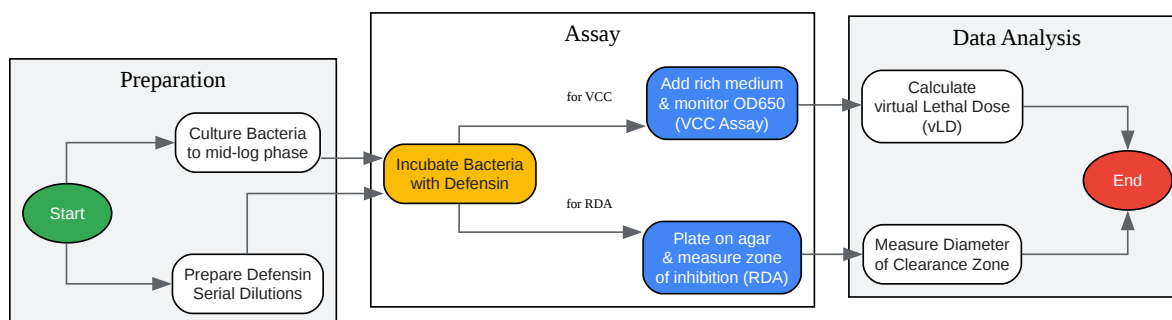

[Click to download full resolution via product page](#)

Workflow for In Vitro Antimicrobial Assays.

Need Custom Synthesis?

BenchChem offers custom synthesis for rare earth carbides and specific isotopic labeling.

Email: info@benchchem.com or [Request Quote Online](#).

References

- 1. Functional Determinants of Human Enteric α -Defensin HD5: CRUCIAL ROLE FOR HYDROPHOBICITY AT DIMER INTERFACE - PMC [[pmc.ncbi.nlm.nih.gov](https://pubmed.ncbi.nlm.nih.gov/)]
- 2. Antibacterial Activity and Specificity of the Six Human α -Defensins - PMC [[pmc.ncbi.nlm.nih.gov](https://pubmed.ncbi.nlm.nih.gov/)]
- 3. journals.asm.org [journals.asm.org]
- 4. journals.asm.org [journals.asm.org]
- 5. Paneth cell - Wikipedia [en.wikipedia.org]
- 6. Mouse Paneth cell defensins: primary structures and antibacterial activities of numerous cryptdin isoforms - PMC [[pmc.ncbi.nlm.nih.gov](https://pubmed.ncbi.nlm.nih.gov/)]
- 7. Peptide Localization and Gene Structure of Cryptdin 4, a Differentially Expressed Mouse Paneth Cell α -Defensin - PMC [[pmc.ncbi.nlm.nih.gov](https://pubmed.ncbi.nlm.nih.gov/)]

- [8. Bactericidal activity of mouse \$\alpha\$ -defensin cryptdin-4 predominantly affects noncommensal bacteria - PubMed \[pubmed.ncbi.nlm.nih.gov\]](#)
- [9. pubs.acs.org \[pubs.acs.org\]](#)
- [10. researchgate.net \[researchgate.net\]](#)
- To cite this document: BenchChem. [Cross-Species Comparison of Alpha-Defensin 5 Function: A Guide for Researchers]. BenchChem, [2026]. [Online PDF]. Available at: [<https://www.benchchem.com/product/b1576409/docs#cross-species-comparison-of-alpha-defensin-5-function-a-guide-for-researchers>]

Disclaimer & Data Validity:

The information provided in this document is for Research Use Only (RUO) and is strictly not intended for diagnostic or therapeutic procedures. While BenchChem strives to provide accurate protocols, we make no warranties, express or implied, regarding the fitness of this product for every specific experimental setup.

Technical Support: The protocols provided are for reference purposes. Unsure if this reagent suits your experiment?

Need Industrial/Bulk Grade? [Request Custom Synthesis Quote](#)

BenchChem

Our mission is to be the trusted global source of essential and advanced chemicals, empowering scientists and researchers to drive progress in science and industry.

Contact

Address: 3281 E Guasti Rd
Ontario, CA 91761, United States
Phone: (601) 213-4426
Email: info@benchchem.com

[Contact our Ph.D. Support Team for a compatibility check](#)

