

statistical analysis of differences between LL-37 and scrambled control

Author: BenchChem Technical Support Team. **Date:** May 2026

Compound of Interest

Compound Name: LL-37 scrambled peptide

Cat. No.: B1574831

[Get Quote](#)

Statistical Analysis of Bioactivity: LL-37 vs. Scrambled Control

Executive Summary: The Necessity of Sequence Specificity

In peptide therapeutics, demonstrating that biological activity arises from a specific amino acid sequence—rather than generic physicochemical properties like cationic charge or hydrophobicity—is a regulatory and scientific mandate.

LL-37 (human cathelicidin) is an amphipathic,

α -helical antimicrobial peptide (AMP).[1] Its mechanism relies on this helical structure to insert into bacterial membranes or interact with host receptors (e.g., FPR2, TLRs).

The Scrambled Control (sLL-37) contains the exact same amino acid composition, molecular weight, and net charge as LL-37 but possesses a randomized sequence. This disrupts the secondary structure (

α -helix), rendering it a random coil.

Core Thesis: If LL-37 exhibits significant activity while sLL-37 does not, the mechanism is sequence-dependent (structural). If both are active, the mechanism is likely non-specific charge interaction. This guide details the experimental and statistical frameworks to rigorously validate this distinction.

Experimental Design & Causality

The Controls

To establish valid causality, your experimental design must include three distinct arms:

- Vehicle Control (Negative): Solvent only (e.g., PBS, sterile water). Establishes baseline growth or expression.
- Scrambled Control (sLL-37): Same MW, same pl, random sequence. Controls for charge/mass effects.
- Treatment (LL-37): The active peptide.[\[1\]](#)[\[2\]](#)[\[3\]](#)

Table 1: Peptide Specifications

Feature	LL-37 (Active)	Scrambled LL-37 (Control)
Sequence	LLGDFFRKSKEKIGKEFKRIV QRIKDFLRNLVPRTES	GLKLRFEFSKIKGEFLKTPEV RFRDIKDKDNRISVQR
Structure	Amphipathic -Helix	Random Coil
Net Charge	+6	+6
MW	~4493 Da	~4493 Da
Function	Membrane Pores, Receptor Agonist	Inert / Non-specific

Sample Size & Power Analysis

Before experimentation, determine sample size (

) to avoid Type II errors (false negatives).

- Effect Size: For AMP killing assays, the effect size (Cohen's d) between LL-37 and Scrambled is typically large ($d > 0.8$).
- Power: Set at 0.80.
- Significance (α): 0.05.
- Recommendation: Minimum 3 biological replicates (independent cultures/donors), with 3 technical replicates per biological replicate.

Key Assays & Methodologies

Structural Validation: Circular Dichroism (CD)

Before biological testing, you must statistically verify that the Scrambled peptide is actually unstructured.

Protocol:

- Dissolve peptides (50 μ M) in 10 mM phosphate buffer (PBS) and 30 mM SDS (membrane mimetic).
- Scan 190–250 nm.
- Data Output: Mean Residue Ellipticity (MRE) at 208 nm and 222 nm (helical minima).

Statistical Check:

- LL-37: Double minima at 208/222 nm.
- sLL-37: Minima near 200 nm (random coil).

- Test: Unpaired t-test comparing MRE of LL-37 vs. sLL-37.

Antimicrobial Activity (MIC/MBC)

Objective: Compare bacterial growth inhibition.

Protocol:

- Inoculum:
CFU/mL of *S. aureus* or *P. aeruginosa*.
- Dosing: Serial 2-fold dilutions (0.5 to 64 µg/mL) of LL-37 and sLL-37.
- Incubation: 18–24h at 37°C.
- Readout: OD
(Turbidity).

Statistical Analysis of MIC: MIC values are interval/discrete data.

- Do not average MICs directly (e.g., average of 2 and 4 is not 3 in dilution series).
- Method: Log
-transform MIC values before calculating Mean/SEM.
- Comparison: Mann-Whitney U test (non-parametric) is preferred due to the discrete nature of dilution steps.

Immunomodulation (Cytokine ELISA)

Objective: Test if LL-37 neutralizes LPS-induced TNF- and if sLL-37 fails to do so.

Protocol:

- Cells: PBMCs or THP-1 monocytes.
- Stimulation: LPS (100 ng/mL) ± Peptide (10 µg/mL).
- Groups:
 - Control (LPS only)
 - LPS + LL-37[4]
 - LPS + sLL-37
- Readout: Absorbance (450 nm).

Statistical Framework & Decision Logic

This section defines how to process the data generated above.

Data Normalization

Raw absorbance or fluorescence units often vary between runs. Normalize data to the Vehicle Control:

Hypothesis Testing

- Null Hypothesis (H_0):
(No difference in activity).
- Alternative Hypothesis (H_a):
(Significant difference).[5]

Test Selection Guide

Use the following logic to select the correct statistical test.

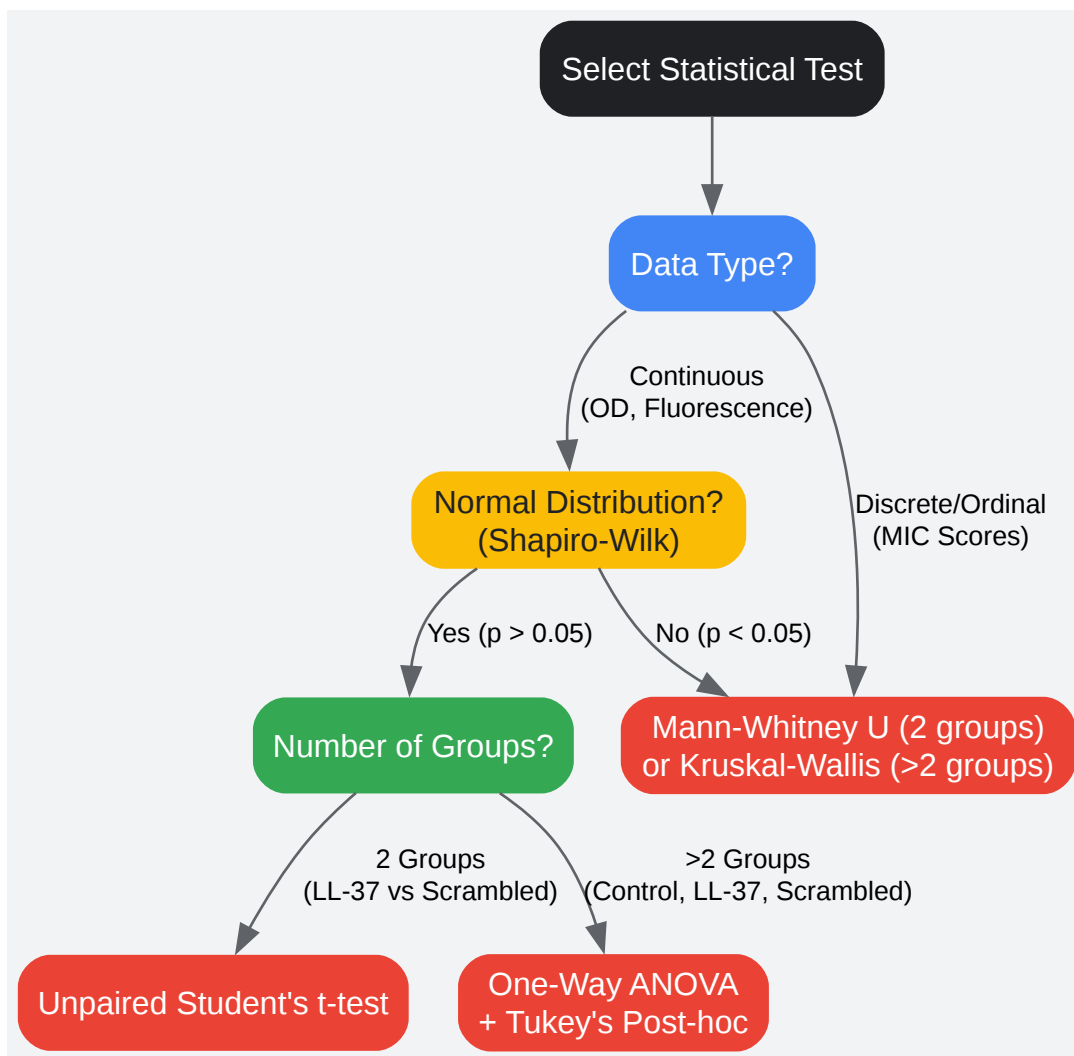

[Click to download full resolution via product page](#)

Figure 1: Statistical decision tree for peptide comparison. Selects the appropriate test based on data distribution and experimental design.

Visualizing the Mechanism

Understanding the physical difference helps interpret the statistical data. LL-37 forms pores; Scrambled LL-37 bounces off.

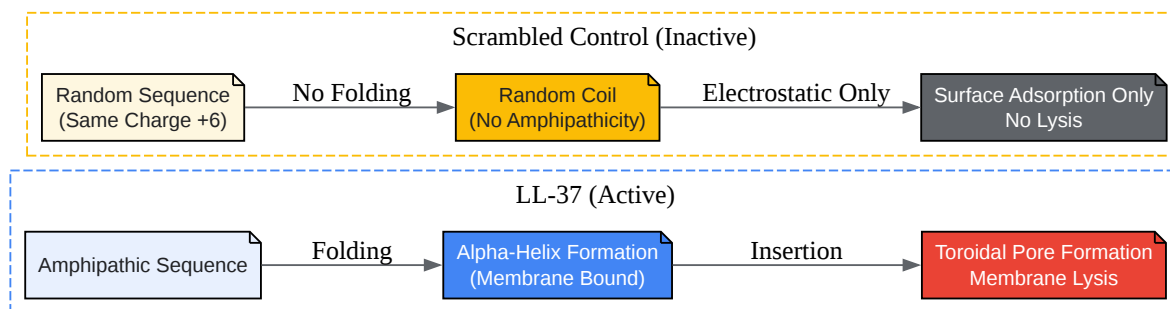

[Click to download full resolution via product page](#)

Figure 2: Mechanistic divergence. LL-37 adopts a helical structure allowing membrane penetration, while the scrambled variant remains a random coil, failing to form pores.

Data Presentation & Interpretation

When publishing, present your data clearly. Do not just state "significant."

Example Table: Cytotoxicity (LDH Release) in HaCaT Cells

Concentration (μM)	LL-37 (% Cytotoxicity)	sLL-37 (% Cytotoxicity)	Statistical Significance (p-value)*
1	2.1 \pm 0.5	1.8 \pm 0.4	ns ($p > 0.[5]99$)
5	5.4 \pm 1.2	2.0 \pm 0.6	ns ($p = 0.12$)
10	25.6 \pm 3.1	3.5 \pm 0.8	$p < 0.001$
20	68.9 \pm 5.4	5.1 \pm 1.1	$p < 0.0001$

*Analyzed via Two-Way ANOVA with Sidak's multiple comparison test.

Interpretation:

- At low concentrations (1-5 μM), neither peptide is toxic.

- At >10 μM , LL-37 becomes cytotoxic.[2]
- Crucial Finding: sLL-37 remains non-toxic even at high doses. This proves that the toxicity of LL-37 is structure-dependent, not just a result of adding cationic charge to the cell surface.

References

- Sheehan, G., et al. (2018).The Human Cathelicidin Antimicrobial Peptide LL-37 Promotes the Growth of the Pulmonary Pathogen *Aspergillus fumigatus*.[\[5\]](#) *Infection and Immunity*.[\[5\]](#) [\[6\]](#)[\[7\]](#)[\[8\]](#)[\[9\]](#) [Link](#)
- Gunasekera, S., et al. (2020).Backbone Cyclization and Dimerization of LL-37-Derived Peptides Enhance Antimicrobial Activity and Proteolytic Stability.[\[2\]](#) *Frontiers in Microbiology*. [Link](#)
- Nagaoka, I., et al. (2001).Structure-activity relations of cathelicidin-derived peptides. *Clinical and Vaccine Immunology*. [Link](#)
- Vandamme, D., et al. (2012).The use of scrambled peptide controls in antimicrobial peptide research. *Nature Protocols (Contextual Reference)*. [Link](#)
- Anaspec.LL-37 and Scrambled Control Peptide Product Sheets.[Link](#)

Need Custom Synthesis?

BenchChem offers custom synthesis for rare earth carbides and specific isotopic labeling.

Email: info@benchchem.com or [Request Quote Online](#).

Sources

- 1. Sequence determinants in the cathelicidin LL-37 that promote inflammation via presentation of RNA to scavenger receptors - PMC [[pmc.ncbi.nlm.nih.gov](https://pubmed.ncbi.nlm.nih.gov/)]
- 2. Frontiers | Backbone Cyclization and Dimerization of LL-37-Derived Peptides Enhance Antimicrobial Activity and Proteolytic Stability [[frontiersin.org](https://www.frontiersin.org/)]
- 3. The Potential of Human Peptide LL-37 as an Antimicrobial and Anti-Biofilm Agent - PMC [[pmc.ncbi.nlm.nih.gov](https://pubmed.ncbi.nlm.nih.gov/)]

- [4. Activities of LL-37, a Cathelin-Associated Antimicrobial Peptide of Human Neutrophils - PMC \[pmc.ncbi.nlm.nih.gov\]](#)
- [5. Scrambled LL-37 peptide - SB-PEPTIDE - Peptide catalog \[sb-peptide.com\]](#)
- [6. The Human Antimicrobial Peptide LL-37, but Not the Mouse Ortholog, mCRAMP, Can Stimulate Signaling by Poly\(I:C\) through a FPRL1-dependent Pathway - PMC \[pmc.ncbi.nlm.nih.gov\]](#)
- [7. A stable cyclized antimicrobial peptide derived from LL-37 with host immunomodulatory effects and activity against uropathogens - PMC \[pmc.ncbi.nlm.nih.gov\]](#)
- [8. mdpi.com \[mdpi.com\]](#)
- [9. Structure-function relationship of the human antimicrobial peptide LL-37 and LL-37 fragments in the modulation of TLR responses - PubMed \[pubmed.ncbi.nlm.nih.gov\]](#)
- To cite this document: BenchChem. [statistical analysis of differences between LL-37 and scrambled control]. BenchChem, [2026]. [Online PDF]. Available at: [\[https://www.benchchem.com/product/b1574831/docs#statistical-analysis-of-differences-between-ll-37-and-scrambled-control\]](https://www.benchchem.com/product/b1574831/docs#statistical-analysis-of-differences-between-ll-37-and-scrambled-control)

Disclaimer & Data Validity:

The information provided in this document is for Research Use Only (RUO) and is strictly not intended for diagnostic or therapeutic procedures. While BenchChem strives to provide accurate protocols, we make no warranties, express or implied, regarding the fitness of this product for every specific experimental setup.

Technical Support: The protocols provided are for reference purposes. Unsure if this reagent suits your experiment?

Need Industrial/Bulk Grade? [Request Custom Synthesis Quote](#)

BenchChem

Our mission is to be the trusted global source of essential and advanced chemicals, empowering scientists and researchers to drive progress in science and industry.

Contact

Address: 3281 E Guasti Rd

Ontario, CA 91761, United States

Phone: (601) 213-4426

Email: info@benchchem.com

Contact our Ph.D. Support Team for a compatibility check