

# Technical Support Center: Impact of TFA Counterions

**Author:** BenchChem Technical Support Team. **Date:** April 2026

## Compound of Interest

Compound Name: [Arg8]-Vasotocin TFA

Cat. No.: B1574896

[Get Quote](#)

Subject: Troubleshooting Experimental Anomalies Caused by Residual TFA Role: Senior Application Scientist Status: Active Guide

## Executive Summary: The "Silent Saboteur"

In peptide synthesis and protein purification, Trifluoroacetic Acid (TFA) is the industry-standard ion-pairing agent. It yields excellent chromatographic resolution and sharp peaks. However, it persists as a counterion (salt) in the final lyophilized product, often comprising 10–40% of the total mass.

The Problem: Researchers often treat the "TFA salt" as an inert bystander. It is not. Residual TFA is a bioactive, chaotropic, and ion-suppressive agent that can silently invalidate LC-MS data, kill sensitive cell lines, and alter protein secondary structure.

## Troubleshooting Module: LC-MS Signal Suppression

**Q: My peptide shows a perfect UV peak at 214 nm, but the MS signal is weak or absent. Is my mass spec broken?**

Diagnosis: You are likely experiencing TFA-mediated Ion Suppression. Mechanism: In the electrospray ionization (ESI) source, the trifluoroacetate anion (

) forms a tight, neutral ion pair with the positively charged basic residues (Arg, Lys, His) and the N-terminus of your peptide.

- Result: The neutral complex cannot be manipulated by the electric fields in the MS source. It remains "invisible" to the detector.
- Visual Proof: High background noise in the low mass range ( $m/z < 200$ ) often indicates TFA clustering.

## Corrective Workflows

Option A: The "Mobile Phase Swap" (Recommended for Screening) Switch your mobile phase modifier from 0.1% TFA to 0.1% Formic Acid (FA).

- Trade-off: FA is a weaker ion-pairing agent.[1] Your peaks may broaden, and retention times will shift earlier.
- Compromise: Use Difluoroacetic Acid (DFA).[2] DFA offers resolution comparable to TFA but with significantly less signal suppression (approx. 2x signal vs. TFA, whereas FA is 10x).

Option B: The "TFA Fix" (Post-Column Modification) If you must use TFA for separation resolution, use a T-junction to infuse a "fixer" solution post-column but pre-source.

- The Fixer: Propionic acid (10%) in Isopropanol (IPA) or dilute Ammonium Hydroxide.
- Why it works: The propionic acid/IPA breaks the TFA-peptide ion pair, liberating the peptide for ionization, while the IPA lowers surface tension to improve desolvation.

Option C: The "Supercharging" Approach Add supercharging agents (e.g., m-NBA or sulfolane) to the mobile phase. These reagents increase the charge state of proteins/peptides, effectively counteracting the charge-masking effect of TFA.

## Troubleshooting Module: Biological Assay Failures

## Q: My cells are dying in the treatment group, but the "Vehicle Control" is fine. The peptide shouldn't be toxic. What is happening?

Diagnosis: TFA Cytotoxicity. Mechanism: TFA is not biologically inert. It is a strong acid (pKa ~0.3)[4][23] that can acidify culture media if buffering capacity is exceeded. More critically, the trifluoroacetate ion itself has intrinsic toxicity.

- Threshold: Toxicity in sensitive lines (e.g., osteoblasts, chondrocytes) has been observed at concentrations as low as 10 nM to 10  $\mu$ M.
- Symptoms:
  - Unexpected apoptosis or necrosis.
  - Altered cellular proliferation rates (TFA can paradoxically stimulate proliferation in some contexts).[5]
  - False positives in enzymatic assays (TFA competes with phosphate groups in kinase/phosphatase assays).[6]

## Q: How do I know if it's the TFA or my peptide?

Validation Protocol:

- Calculate: A 1 mg sample of peptide (MW 1000) with 3 basic residues (Arg, Lys, His) is likely a tris-TFA salt. The TFA mass is approx.  
  
. This is ~25% of your total weight!
- Control Experiment: Run a "TFA-only" control. Add sodium trifluoroacetate to your blank media at the molar equivalent of your peptide dose. If cells die, it's the counterion, not the peptide.

## Data Presentation: Counterion Selection Matrix

Use this table to select the correct salt form before ordering or purifying your peptide.

Feature	TFA Salt	Acetate Salt	Hydrochloride (HCl) Salt
Primary Use	HPLC Purification, Initial Synthesis	Cell Culture, In Vivo Studies	Stability Studies, Formulation
Solubility	High (usually)	High	Very High (often > TFA)
Acidity (pKa)	Strong Acid (~0.[3][4][7]23)	Weak Acid (~4.76)	Strong Acid (~ -7)
LC-MS Signal	Suppressed (Poor)	Good	Good
Cell Toxicity	High (nM - $\mu$ M range)	Low (Biocompatible)	Moderate (pH dependent)
Hygroscopicity	Moderate	Low (Easy to handle)	High (Can be sticky)
Cost	Standard (Cheapest)	+20-30% (Requires exchange)	+20-30% (Requires exchange)

## Master Protocols: Counterion Exchange[4]

If you already have a TFA salt and need to fix it, use one of the following self-validating protocols.

### Protocol A: The "Lyophilization Loop" (TFA HCl)

Best for: Small batches (<50 mg), high solubility peptides.

- Dissolve: Dissolve peptide in 2–10 mM HCl (approx. 1 mg/mL).
  - Note: Do not use strong HCl (>100 mM) as it may degrade sensitive residues (Asp-Pro cleavage).
- Incubate: Let stand for 5 minutes at room temperature. The massive excess of  $\text{Cl}^-$  ions will displace the  $\text{TFA}^-$  ions.
- Freeze & Lyophilize: Freeze in liquid nitrogen and lyophilize to dryness.

- Mechanism:[3][4][8] HCl is volatile. TFA is volatile. As they evaporate, the equilibrium shifts.
- Repeat:Crucial Step. Repeat steps 1–3 at least 3 times.
  - Validation: After 3 cycles, TFA content is typically <1%.[9]
- Final Step: Re-dissolve in water and lyophilize one last time to remove excess HCl.

## Protocol B: The "Resin Swap" (TFA Acetate)

Best for: Large batches, peptides sensitive to low pH.

- Resin Prep: Use a strong anion exchange resin (e.g., Dowex 1x2 or equivalent) in the Acetate form.
  - Capacity Check: Ensure resin capacity is 100x the molar equivalents of the peptide.
- Equilibration: Wash resin with 1M Sodium Acetate, then rinse thoroughly with distilled water until the eluate pH is neutral.
- Loading: Dissolve peptide in water (or minimal % acetic acid if insoluble) and load onto the column.
- Elution: Elute with water. The peptide (positively charged) passes through; the TFA anions exchange with the Acetate anions on the resin.
- Lyophilize: Freeze-dry the eluate.

## Visualizing the "Hidden Variable"

### Diagram 1: The Mechanism of LC-MS Signal Suppression

This diagram illustrates why your MS detector fails to "see" the peptide in the presence of TFA.

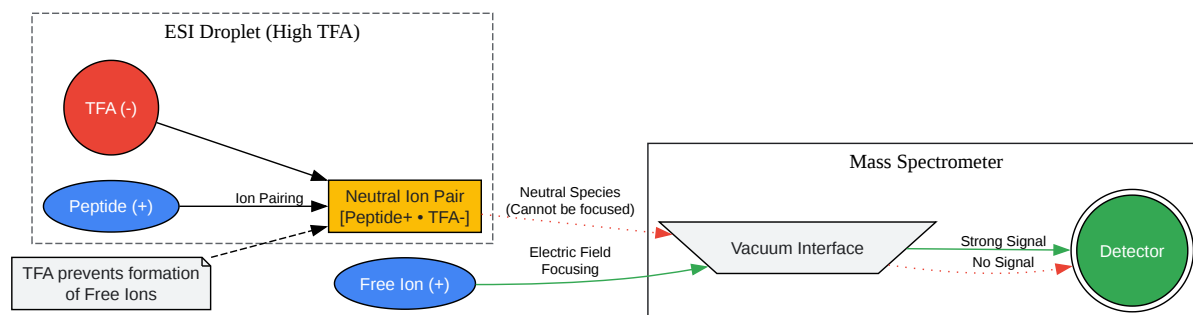

[Click to download full resolution via product page](#)

Caption: TFA anions pair with cationic peptides, forming neutral complexes that resist electrospray ionization.

## Diagram 2: Counterion Decision Tree

Follow this logic flow to determine if you need to perform a salt exchange.

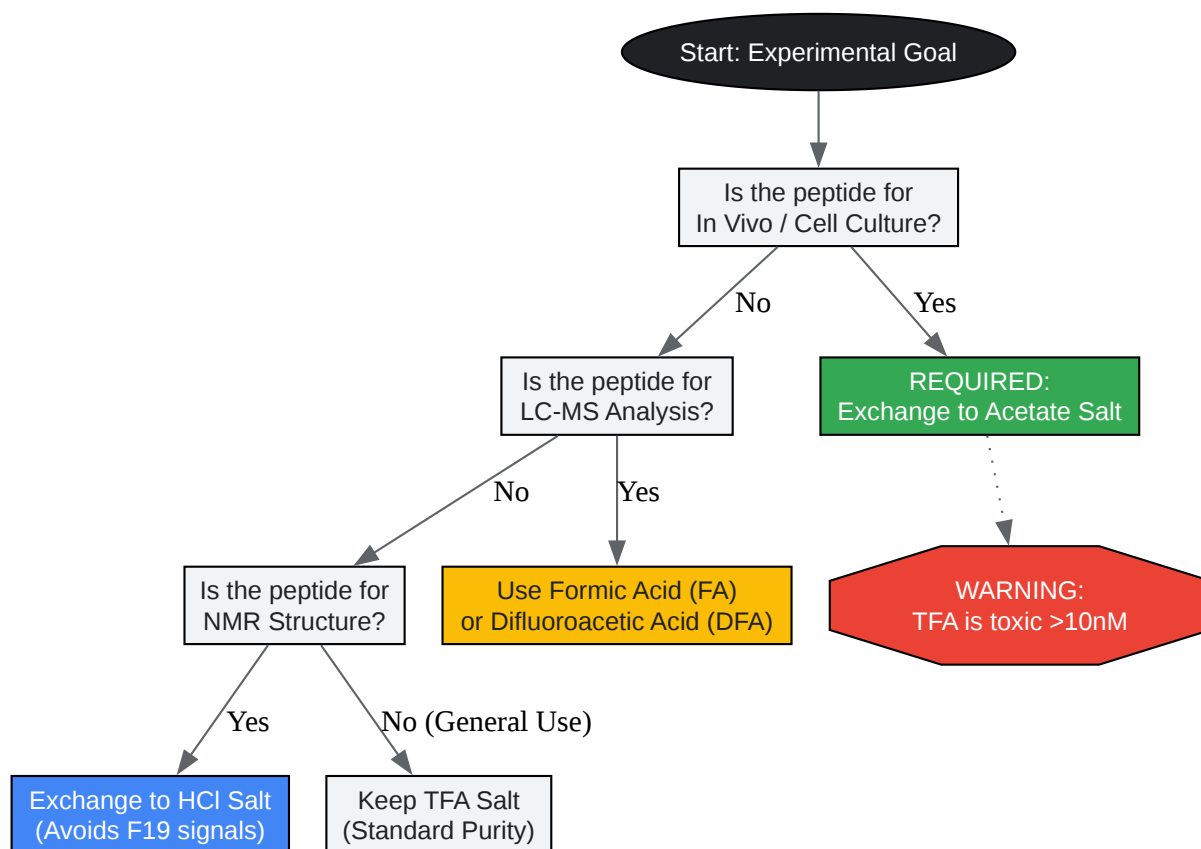

[Click to download full resolution via product page](#)

Caption: Logical workflow for selecting the appropriate counterion based on downstream applications.

## References

- TFA Signal Suppression in LC-MS
  - Chan, C. C., et al. "Mitigation of signal suppression caused by the use of trifluoroacetic acid in liquid chromatography mobile phases during liquid chromatography/mass spectrometry analysis via post-column addition of ammonium hydroxide." [10] Rapid Communications in Mass Spectrometry, 2012.

- TFA Cytotoxicity in Cell Culture
  - Cornish, J., et al. "Trifluoroacetate, a contaminant in purified proteins, inhibits proliferation of osteoblasts and chondrocytes." American Journal of Physiology-Endocrinology and Metabolism, 1999.
- Counterion Effects on Peptide Structure
  - Gaussier, H., et al.[11] "The Effects of Counter-Ions on Peptide Structure, Activity, and Applications." International Journal of Peptide Research and Therapeutics, 2002.
- Salt Exchange Protocols (HCl & Acetate)
  - Sikora, K., et al. "Removing Trifluoroacetic Acid (TFA) From Peptides: Technical Support Information Bulletin 1085." Peptide Institute / BenchChem Guidelines.
- Difluoroacetic Acid (DFA)
  - Waters Corporation. "Difluoroacetic Acid as an Effective Mobile Phase Modifier for the LC-UV/MS Analysis of Proteins.

### Need Custom Synthesis?

BenchChem offers custom synthesis for rare earth carbides and specific isotopic labeling.

Email: [info@benchchem.com](mailto:info@benchchem.com) or [Request Quote Online](#).

## Sources

- [1. lcms.cz \[lcms.cz\]](#)
- [2. waters.com \[waters.com\]](#)
- [3. researchgate.net \[researchgate.net\]](#)
- [4. Elimination and exchange of trifluoroacetate counter-ion from cationic peptides: a critical evaluation of different approaches - PubMed \[pubmed.ncbi.nlm.nih.gov\]](#)
- [5. genscript.com.cn \[genscript.com.cn\]](#)
- [6. lifetein.com \[lifetein.com\]](#)

- 7. The impact of counterions in biological activity: case study of antibacterial alkylguanidino ureas - PMC [[pmc.ncbi.nlm.nih.gov](https://pubmed.ncbi.nlm.nih.gov)]
- 8. Enhancing Sensitivity of Liquid Chromatography–Mass Spectrometry of Peptides and Proteins Using Supercharging Agents - PMC [[pmc.ncbi.nlm.nih.gov](https://pubmed.ncbi.nlm.nih.gov)]
- 9. [pdf.benchchem.com](https://pdf.benchchem.com) [[pdf.benchchem.com](https://pdf.benchchem.com)]
- 10. Mitigation of signal suppression caused by the use of trifluoroacetic acid in liquid chromatography mobile phases during liquid chromatography/mass spectrometry analysis via post-column addition of ammonium hydroxide - PubMed [[pubmed.ncbi.nlm.nih.gov](https://pubmed.ncbi.nlm.nih.gov)]
- 11. [mdpi.com](https://mdpi.com) [[mdpi.com](https://mdpi.com)]
- To cite this document: BenchChem. [Technical Support Center: Impact of TFA Counterions]. BenchChem, [2026]. [Online PDF]. Available at: [<https://www.benchchem.com/product/b1574896/docs#technical-support-center-impact-of-tfa-counterions>]

---

#### Disclaimer & Data Validity:

The information provided in this document is for Research Use Only (RUO) and is strictly not intended for diagnostic or therapeutic procedures. While BenchChem strives to provide accurate protocols, we make no warranties, express or implied, regarding the fitness of this product for every specific experimental setup.

**Technical Support:** The protocols provided are for reference purposes. Unsure if this reagent suits your experiment?

**Need Industrial/Bulk Grade?** [Request Custom Synthesis Quote](#)

## BenchChem

Our mission is to be the trusted global source of essential and advanced chemicals, empowering scientists and researchers to drive progress in science and industry.

#### Contact

Address: 3281 E Guasti Rd

Ontario, CA 91761, United States

Phone: (601) 213-4426

Email: [info@benchchem.com](mailto:info@benchchem.com)

Contact our Ph.D. Support Team for a compatibility check