

Profiling Chromatin Alterations Induced by the LSD1 Inhibitor INCB059872 using ChIP-seq

Author: BenchChem Technical Support Team. **Date:** April 2026

Compound of Interest

Compound Name: *INCB059872*

Cat. No.: *B1574622*

[Get Quote](#)

Application Note & Detailed Protocol

For Researchers, Scientists, and Drug Development Professionals.

Abstract

This document provides a comprehensive guide for utilizing Chromatin Immunoprecipitation followed by sequencing (ChIP-seq) to investigate the epigenetic modifications induced by **INCB059872**, a potent and selective inhibitor of Lysine-Specific Demethylase 1 (LSD1). We delve into the mechanism of action of **INCB059872**, detail a robust ChIP-seq protocol optimized for detecting histone methylation changes, and provide insights into the critical experimental choices and data interpretation. This guide is intended to equip researchers with the necessary knowledge to successfully design, execute, and analyze ChIP-seq experiments for studying the effects of **INCB059872** and other LSD1 inhibitors on the chromatin landscape.

Introduction: **INCB059872** and the Role of LSD1 in Gene Regulation

INCB059872 is an orally bioavailable small molecule that acts as a potent and selective, irreversible inhibitor of Lysine-Specific Demethylase 1 (LSD1), also known as KDM1A.[1][2] LSD1 is a flavin adenine dinucleotide (FAD)-dependent amine oxidase that plays a crucial role in epigenetic regulation by catalyzing the demethylation of specific histone residues.[3][4] Specifically, LSD1 removes mono- and di-methyl groups from histone H3 at lysine 4 (H3K4me1/2) and lysine 9 (H3K9me1/2).[3]

The methylation status of these histone residues is critical for gene expression. H3K4 methylation is generally associated with active gene transcription, while H3K9 methylation is a hallmark of transcriptional repression.[4] By inhibiting LSD1, **INCB059872** prevents the demethylation of H3K4 and H3K9, leading to an accumulation of these methylation marks.[2] This alteration in the histone code can reactivate the expression of silenced tumor suppressor genes and modulate other cancer-related pathways, making LSD1 inhibitors like **INCB059872** a promising therapeutic strategy in oncology, particularly for myeloid leukemias and small cell lung cancer.[4][5][6]

ChIP-seq is a powerful technique to map the genome-wide distribution of specific histone modifications.[7][8] By performing ChIP-seq for H3K4me1/2 and H3K9me1/2 in the presence and absence of **INCB059872**, researchers can gain valuable insights into the compound's mechanism of action, identify its direct and indirect targets, and understand its impact on the epigenetic landscape of cancer cells.

Mechanism of Action of INCB059872

INCB059872 functions by forming a covalent adduct with the FAD cofactor of LSD1, leading to its irreversible inhibition.[4][9] This targeted inhibition of LSD1's demethylase activity is expected to result in a global increase in H3K4me1/2 and H3K9me1/2 levels at specific genomic loci. However, studies have shown that the resulting changes in histone methylation can be subtle and context-dependent.[6][10] Therefore, a meticulously designed and executed ChIP-seq experiment is paramount for accurately capturing these epigenetic alterations.

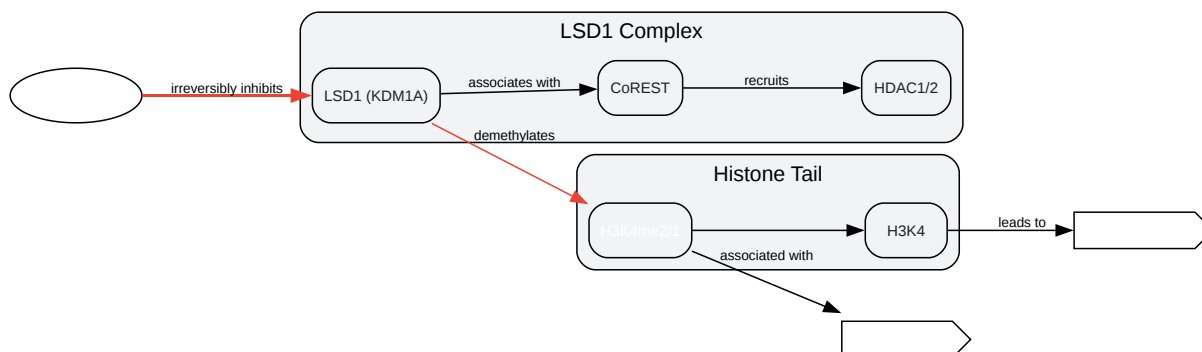

[Click to download full resolution via product page](#)

Caption: Mechanism of **INCB059872** action on LSD1-mediated histone demethylation.

Experimental Design Considerations for ChIP-seq with **INCB059872**

A well-controlled experiment is crucial for obtaining reliable and interpretable ChIP-seq data. Below are key considerations when designing your study.

Parameter	Recommendation	Rationale
Cell Line Selection	Choose a cell line known to be sensitive to LSD1 inhibition (e.g., AML or SCLC cell lines). [4] [6]	Ensures a measurable biological response to INCB059872 treatment.
INCB059872 Concentration	Determine the EC50 for the chosen cell line and use a concentration at or slightly above this value (e.g., 25-100 nM). [1] [4]	To achieve significant target engagement without inducing excessive off-target effects or cytotoxicity.
Treatment Duration	A time-course experiment (e.g., 24, 48, 72 hours) is recommended. [6]	Changes in histone methylation can be dynamic. A time-course can capture both early and late effects.
Antibody Selection	Use highly specific, ChIP-grade antibodies for H3K4me1, H3K4me2, H3K9me1, and H3K9me2. Validate antibody specificity via Western blot.	Ensures that the immunoprecipitated DNA is enriched for the histone mark of interest.
Controls	Include a vehicle-treated control (e.g., DMSO) and an IgG isotype control for each condition. An input control (sonicated chromatin without immunoprecipitation) is also essential. [11]	Vehicle controls for solvent effects. IgG controls for non-specific antibody binding. Input controls for chromatin accessibility bias.
Replicates	A minimum of two biological replicates for each condition is recommended. [11]	To assess the reproducibility of the results and perform statistical analysis of differential binding.

Detailed ChIP-seq Protocol

This protocol is a general guideline and may require optimization for specific cell types and experimental conditions.

Cell Culture and Treatment

- Culture cells to ~80% confluency.
- Treat cells with the desired concentration of **INCB059872** or vehicle control for the specified duration.

Chromatin Cross-linking and Cell Lysis

- Cross-link proteins to DNA by adding formaldehyde directly to the culture medium to a final concentration of 1% and incubate for 10 minutes at room temperature with gentle shaking. [\[12\]](#)
- Quench the cross-linking reaction by adding glycine to a final concentration of 125 mM and incubate for 5 minutes at room temperature. [\[12\]](#)
- Harvest cells, wash with ice-cold PBS, and pellet by centrifugation.
- Lyse the cell pellet with a suitable lysis buffer containing protease inhibitors.

Chromatin Sonication

- Resuspend the nuclear pellet in a sonication buffer.
- Sonicate the chromatin to an average fragment size of 200-500 bp. Optimization of sonication conditions (power, duration, cycles) is critical for successful CHIP. [\[12\]](#)
- Verify the fragment size by running an aliquot of the sonicated chromatin on an agarose gel.

Immunoprecipitation

- Pre-clear the chromatin with Protein A/G magnetic beads to reduce non-specific background. [\[13\]](#)
- Incubate the pre-cleared chromatin with the specific primary antibody (anti-H3K4me1/2, anti-H3K9me1/2, or IgG control) overnight at 4°C with rotation.

- Add Protein A/G magnetic beads to capture the antibody-chromatin complexes. Incubate for 2-4 hours at 4°C.
- Wash the beads sequentially with low salt, high salt, LiCl, and TE buffers to remove non-specifically bound proteins.[\[13\]](#)

Elution and Reverse Cross-linking

- Elute the chromatin from the beads using an elution buffer (e.g., 1% SDS, 0.1 M NaHCO₃).
- Reverse the cross-links by adding NaCl and incubating at 65°C for at least 4 hours.[\[13\]](#)
- Treat with RNase A and Proteinase K to remove RNA and proteins.[\[14\]](#)

DNA Purification and Library Preparation

- Purify the DNA using a PCR purification kit or phenol-chloroform extraction.[\[12\]](#)
- Quantify the purified DNA.
- Prepare the ChIP-seq libraries according to the manufacturer's instructions for your sequencing platform.

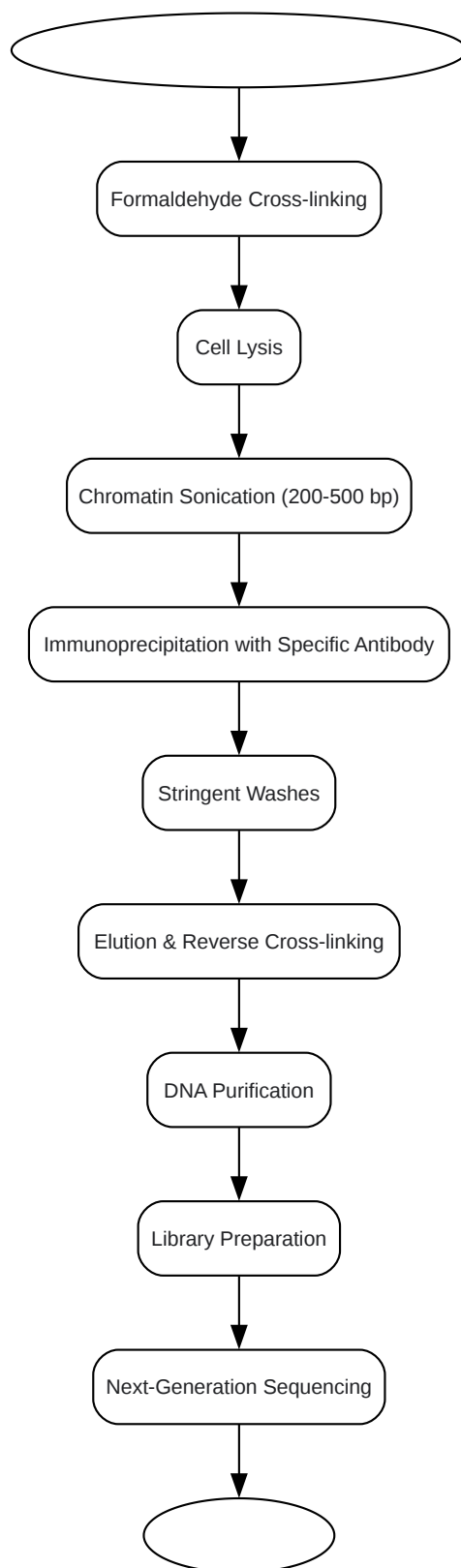

[Click to download full resolution via product page](#)

Caption: A streamlined workflow for a ChIP-seq experiment.

Data Analysis Pipeline

A standard ChIP-seq data analysis pipeline can be adapted for studying the effects of **INCB059872**.

- **Quality Control:** Assess the quality of the raw sequencing reads using tools like FastQC.
- **Read Alignment:** Align the reads to the appropriate reference genome using aligners such as BWA or Bowtie2.[\[15\]](#)[\[16\]](#)
- **Peak Calling:** Identify regions of histone modification enrichment (peaks) using peak callers like MACS2. Use the input DNA as a control to account for background noise and chromatin accessibility bias.[\[15\]](#)[\[16\]](#)
- **Differential Binding Analysis:** Identify genomic regions with statistically significant changes in histone modification levels between **INCB059872**-treated and control samples using tools like DiffBind or DESeq2.
- **Peak Annotation and Functional Analysis:** Annotate the differential peaks to nearby genes and perform gene ontology (GO) and pathway analysis to understand the biological processes affected by **INCB059872**.
- **Data Visualization:** Visualize the ChIP-seq signal at specific genomic loci using a genome browser like IGV or UCSC Genome Browser. Generate heatmaps and metaplots to visualize global changes in histone modifications.

Interpreting the Results

Given that **INCB059872** is an LSD1 inhibitor, the primary expectation is an increase in H3K4me1/2 and H3K9me1/2 at specific genomic regions. However, as noted in the literature, the observed changes may be subtle.[\[6\]](#)[\[10\]](#) Therefore, it is important to:

- **Focus on statistically significant changes:** Rely on the output of differential binding analysis to identify robust changes.
- **Integrate with other data types:** Correlate the changes in histone modifications with gene expression data (RNA-seq) to understand the functional consequences of the epigenetic

alterations.

- Consider the genomic context: Analyze the distribution of differential peaks relative to genomic features such as promoters, enhancers, and gene bodies.

Conclusion

ChIP-seq is an indispensable tool for elucidating the genome-wide effects of epigenetic modulators like **INCB059872**. By carefully designing the experiment, following a robust protocol, and employing a rigorous data analysis pipeline, researchers can gain deep insights into the mechanism of action of LSD1 inhibitors and their impact on the chromatin landscape. This knowledge is critical for advancing our understanding of cancer epigenetics and for the development of novel therapeutic strategies.

References

- DelveInsight. Lysine Specific Demethylase 1 (LSD-1) Inhibitor Pipeline Insight. [\[Link\]](#)
- National Cancer Institute. Definition of lysine-specific demethylase 1 inhibitor **INCB059872** - NCI Drug Dictionary. [\[Link\]](#)
- ASH Publications. Nascent Transcript and Single Cell Rnaseq Analysis Defines the Mechanism of Action of the LSD1 Inhibitor **INCB059872** in Myeloid Leukemia | Blood. [\[Link\]](#)
- PubMed. Nascent transcript and single-cell RNA-seq analysis defines the mechanism of action of the LSD1 inhibitor **INCB059872** in myeloid leukemia. [\[Link\]](#)
- PMC. A ChIP-Seq Data Analysis Pipeline Based on Bioconductor Packages. [\[Link\]](#)
- CD Genomics. Pipeline and Tools for ChIP-Seq Analysis. [\[Link\]](#)
- GitHub. winston-lab/chip-seq: ChIP-seq analysis pipeline. [\[Link\]](#)
- Taylor & Francis Online. BET Proteins are a Key Component of Immunoglobulin Gene Expression. [\[Link\]](#)
- PMC. LSD1 inhibitors for cancer treatment: Focus on multi-target agents and compounds in clinical trials. [\[Link\]](#)

- ENCODE. Transcription Factor ChIP-seq Data Standards and Processing Pipeline. [\[Link\]](#)
- ResearchGate. Abstract 4704: The evaluation of **INCB059872**, an FAD-directed inhibitor of LSD1, in preclinical models of human small cell lung cancer. [\[Link\]](#)
- STAR Protocols. Protocol to apply spike-in ChIP-seq to capture massive histone acetylation in human cells. [\[Link\]](#)
- AACR Journals. Abstract 1379: **INCB059872**, a novel FAD-directed LSD1 Inhibitor, is active in prostate cancer models and impacts prostate cancer stem-like cells. [\[Link\]](#)
- MDPI. Bromodomain and Extra-Terminal Proteins in Brain Physiology and Pathology: BET-ing on Epigenetic Regulation. [\[Link\]](#)
- PMC. The Functions of BET Proteins in Gene Transcription of Biology and Diseases. [\[Link\]](#)
- GenPipes. ChIP Sequencing Pipeline. [\[Link\]](#)
- PMC. A Comprehensive Review of BET Protein Biochemistry, Physiology, and Pathological Roles. [\[Link\]](#)
- PMC. ChIP-seq guidelines and practices of the ENCODE and modENCODE consortia. [\[Link\]](#)
- ResearchGate. Role of BET proteins in transcriptional regulation. [\[Link\]](#)
- AACR Journals. Abstract 4712: Discovery of **INCB059872**, a novel FAD-directed LSD1 inhibitor that is effective in preclinical models of human and murine AML. [\[Link\]](#)
- ENCODE. ChIP-Seq Protocol (Snyder lab, Stanford University, 2012). [\[Link\]](#)
- CD Genomics. Chromatin Immunoprecipitation Sequencing (ChIP-seq) Protocol. [\[Link\]](#)
- Creative Diagnostics. Chromatin Immunoprecipitation (ChIP) Protocol. [\[Link\]](#)
- STAR Protocols. An Optimized Protocol for ChIP-Seq from Human Embryonic Stem Cell Cultures. [\[Link\]](#)
- PMC. BET inhibition disrupts transcription but retains enhancer-promoter contact. [\[Link\]](#)

- PMC. Functional coordination of BET family proteins underlies altered transcription associated with memory impairment in fragile X syndrome. [[Link](#)]
- ResearchGate. Nascent Transcript and Single Cell Rnaseq Analysis Defines the Mechanism of Action of the LSD1 Inhibitor **INCB059872** in Myeloid Leukemia | Request PDF. [[Link](#)]
- MDPI. Lysine-Specific Demethylase 1 (LSD1)-Mediated Epigenetic Modification of Immunogenicity and Immunomodulatory Effects in Breast Cancers. [[Link](#)]
- YouTube. [[Link](#)]
- VJHemOnc. A Phase II study of the LSD1 inhibitor bomedemstat in patients with polycythemia vera. [[Link](#)]
- YouTube. [[Link](#)]
- VJHemOnc. BTK inhibitors in the treatment of DLBCL: trials investigating these agents. [[Link](#)]

Need Custom Synthesis?

BenchChem offers custom synthesis for rare earth carbides and specific isotopic labeling.

Email: info@benchchem.com or [Request Quote Online](#).

Sources

- 1. medchemexpress.com [medchemexpress.com]
- 2. [Facebook](https://www.facebook.com/cancer.gov) [[cancer.gov](https://www.facebook.com/cancer.gov)]
- 3. LSD1 inhibitors for cancer treatment: Focus on multi-target agents and compounds in clinical trials - PMC [[pmc.ncbi.nlm.nih.gov](https://pubmed.ncbi.nlm.nih.gov/)]
- 4. [researchgate.net](https://www.researchgate.net) [[researchgate.net](https://www.researchgate.net)]
- 5. Lysine Specific Demethylase 1 (LSD-1) Inhibitor Pipeline Insight [delveinsight.com]
- 6. [ashpublications.org](https://www.ashpublications.org) [[ashpublications.org](https://www.ashpublications.org)]
- 7. A CHIP-Seq Data Analysis Pipeline Based on Bioconductor Packages - PMC [[pmc.ncbi.nlm.nih.gov](https://pubmed.ncbi.nlm.nih.gov/)]

- [8. Pipeline and Tools for ChIP-Seq Analysis - CD Genomics \[cd-genomics.com\]](#)
- [9. aacrjournals.org \[aacrjournals.org\]](#)
- [10. researchgate.net \[researchgate.net\]](#)
- [11. encodeproject.org \[encodeproject.org\]](#)
- [12. creative-diagnostics.com \[creative-diagnostics.com\]](#)
- [13. Chromatin Immunoprecipitation Sequencing \(ChIP-seq\) Protocol - CD Genomics \[cd-genomics.com\]](#)
- [14. encodeproject.org \[encodeproject.org\]](#)
- [15. GitHub - winston-lab/chip-seq: ChIP-seq analysis pipeline \[github.com\]](#)
- [16. ChIP Sequencing Pipeline — GenPipes 3.6.2 \(0.9 draft \) documentation \[genpipes.readthedocs.io\]](#)
- [To cite this document: BenchChem. \[Profiling Chromatin Alterations Induced by the LSD1 Inhibitor INCB059872 using ChIP-seq\]. BenchChem, \[2026\]. \[Online PDF\]. Available at: \[https://www.benchchem.com/product/b1574622/docs#profiling-chromatin-alterations-induced-by-the-lsd1-inhibitor-incb059872-using-chip-seq\]](#)

Disclaimer & Data Validity:

The information provided in this document is for Research Use Only (RUO) and is strictly not intended for diagnostic or therapeutic procedures. While BenchChem strives to provide accurate protocols, we make no warranties, express or implied, regarding the fitness of this product for every specific experimental setup.

Technical Support: The protocols provided are for reference purposes. Unsure if this reagent suits your experiment?

Need Industrial/Bulk Grade? [Request Custom Synthesis Quote](#)

BenchChem

Our mission is to be the trusted global source of essential and advanced chemicals, empowering scientists and researchers to drive progress in science and industry.

Contact

Address: 3281 E Guasti Rd

Ontario, CA 91761, United States

Phone: (601) 213-4426

Email: info@benchchem.com

[Contact our Ph.D. Support Team for a compatibility check](#)