

# Cross-validation of N-Acetyl-Phe-Octreotide Detection Methods

**Author:** BenchChem Technical Support Team. **Date:** April 2026

## Compound of Interest

Compound Name: *N-Acetyl-Phe-Octreotide*

Cat. No.: *B1574728*

[Get Quote](#)

## Executive Summary

**N-Acetyl-Phe-Octreotide** (often designated as [Phe(Ac)]<sup>1</sup>-Octreotide or Octreotide EP Impurity I) is a critical process-related impurity in the synthesis of Octreotide Acetate. Structurally, it results from the acetylation of the N-terminal D-Phenylalanine residue, a modification that caps the primary amine, altering both the hydrophobicity and the net charge of the peptide.

Detecting this impurity presents a unique analytical challenge: its structural similarity to the parent peptide leads to co-elution in standard reversed-phase systems, while its lack of a free N-terminal amine reduces ionization efficiency in mass spectrometry compared to the parent drug.

This guide provides a technical framework for the cross-validation of three distinct analytical methodologies: RP-HPLC, LC-MS/MS, and Capillary Zone Electrophoresis (CZE). By leveraging the orthogonal separation mechanisms of hydrophobicity (HPLC), mass-to-charge ratio (MS), and electrophoretic mobility (CZE), researchers can establish a self-validating control strategy compliant with ICH Q2(R1) and pharmacopoeial standards.

## Part 1: The Analytical Challenge

The detection of **N-Acetyl-Phe-Octreotide** is complicated by two physicochemical factors:

- **Hydrophobic Shift:** The acetylation of the N-terminus removes a hydrophilic amine group, increasing the peptide's retention on C18 columns. It often elutes in the "tail" of the main Octreotide peak or co-elutes with other hydrophobic impurities like oligomers.
- **Charge Suppression:** At acidic pH (used in most mobile phases), the N-terminus of Octreotide is protonated ( ). Acetylation converts this to a neutral amide ( ). This loss of charge fundamentally alters its behavior in CZE and reduces its sensitivity in positive-mode ESI-MS.

## Impurity Profile Visualization

The following diagram illustrates the separation logic required to isolate this specific impurity.

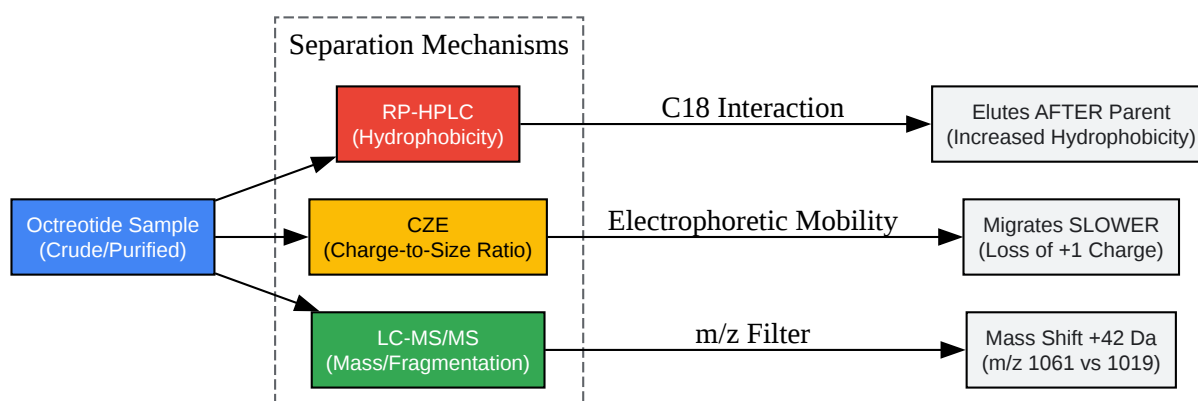

[Click to download full resolution via product page](#)

Figure 1: Orthogonal separation logic for **N-Acetyl-Phe-Octreotide**. Each method exploits a different physicochemical change caused by N-terminal acetylation.

## Part 2: Experimental Protocols & Methodologies

## Methodology 1: High-Performance Liquid Chromatography (HPLC-UV)

The Workhorse for Routine QC

Objective: To separate **N-Acetyl-Phe-Octreotide** based on hydrophobic interaction. Critical

Insight: Standard TFA gradients may not resolve the acetyl impurity from the parent tail. A shallow gradient slope at the elution point is critical.

Parameter	Specification
Column	C18, 250 x 4.6 mm, 5 $\mu$ m (e.g., Kromasil or equivalent)
Mobile Phase A	0.1% Trifluoroacetic Acid (TFA) in Water
Mobile Phase B	0.1% TFA in Acetonitrile
Flow Rate	1.0 mL/min
Detection	UV at 210 nm (Amide bond absorption)
Gradient	20-40% B over 30 mins (Linear).[1] Note: Flatten gradient to 0.5% B/min around expected elution time (15-20 min) to maximize resolution ( ).
Target	between Octreotide and N-Acetyl-Impurity

## Methodology 2: Liquid Chromatography-Mass Spectrometry (LC-MS)

The Specificity King for Identification

Objective: To confirm identity via mass shift (+42 Da) and quantify at trace levels (cleaning validation). Critical Insight: Avoid TFA in LC-MS as it suppresses ionization. Use Formic Acid (FA).[1] The loss of the N-terminal charge means the impurity may ionize primarily as

or

with different ratios than the parent.

Parameter	Specification
Column	C18 UHPLC, 100 x 2.1 mm, 1.7 $\mu$ m
Mobile Phase A	0.1% Formic Acid in Water
Mobile Phase B	0.1% Formic Acid in Acetonitrile
Ionization	ESI Positive Mode
Mass Targets	Octreotide: 510.5 ( ), 1019.5 ( ) N-Acetyl-Impurity: 531.5 ( ), 1061.5 ( )
LOD Target	ng/mL (suitable for cleaning validation)

## Methodology 3: Capillary Zone Electrophoresis (CZE)

The Orthogonal Validator

Objective: To validate purity based on charge state, eliminating false negatives from HPLC co-elution. Critical Insight: At pH 3.2, Octreotide has multiple positive charges (N-term, Lysine). N-acetylation removes one positive charge. This results in a significantly lower electrophoretic mobility, causing the impurity to migrate distinctly slower than the parent.

Parameter	Specification
Capillary	Bare Fused Silica, 50 µm ID x 60 cm effective length
Buffer	10-50 mM Ammonium Formate, pH 3.20
Voltage	25 kV (Normal Polarity)
Temperature	25°C
Detection	UV at 200 nm
Migration Order	1. Octreotide (Higher Charge) 2. N-Acetyl-Phe-Octreotide (Lower Charge)

## Part 3: Cross-Validation Framework

To ensure the "N-Acetyl" impurity is accurately quantified, you must cross-validate the methods. This prevents "method bias" where one technique systematically under-reports the impurity.

### Linearity & Range Comparison

Construct calibration curves for **N-Acetyl-Phe-Octreotide** standard (available as Octreotide EP Impurity I) in both HPLC and LC-MS.

- HPLC Range: 0.05% to 5.0% of target concentration (0.5 mg/mL).
- LC-MS Range: 1 ng/mL to 1000 ng/mL.[2]
- Acceptance:  
for both.[1]

### Relative Response Factor (RRF) Determination

In HPLC-UV, the acetylation does not significantly alter the chromophore (phenylalanine ring is intact). Therefore, the RRF should be close to 1.0.

- Experiment: Inject equimolar amounts of Octreotide and N-Acetyl-Impurity.

- Calculation:
- Validation: If RRF is within 0.9–1.1, you can use the parent standard for quantification in routine QC.

## Bland-Altman Analysis (Method Comparability)

Analyze 5 batches of Octreotide with varying levels of the impurity using both HPLC and CZE. Plot the difference vs. average.

- X-Axis:
- Y-Axis:
- Interpretation: If CZE consistently shows higher impurity levels, your HPLC method likely suffers from co-elution (the impurity is hiding under the main peak).

## Comparative Performance Data (Example)

Metric	RP-HPLC (UV)	LC-MS/MS	CZE
Specificity	Moderate (Risk of co-elution)	High (Mass resolved)	High (Charge resolved)
LOD	~0.05% (Area)	~0.1 ng/mL	~0.1% (Area)
Precision (RSD)	< 1.0%	< 5.0%	< 2.0%
Primary Use	Batch Release / QC	Cleaning Validation / ID	Orthogonal Purity Check

## Cross-Validation Workflow Diagram

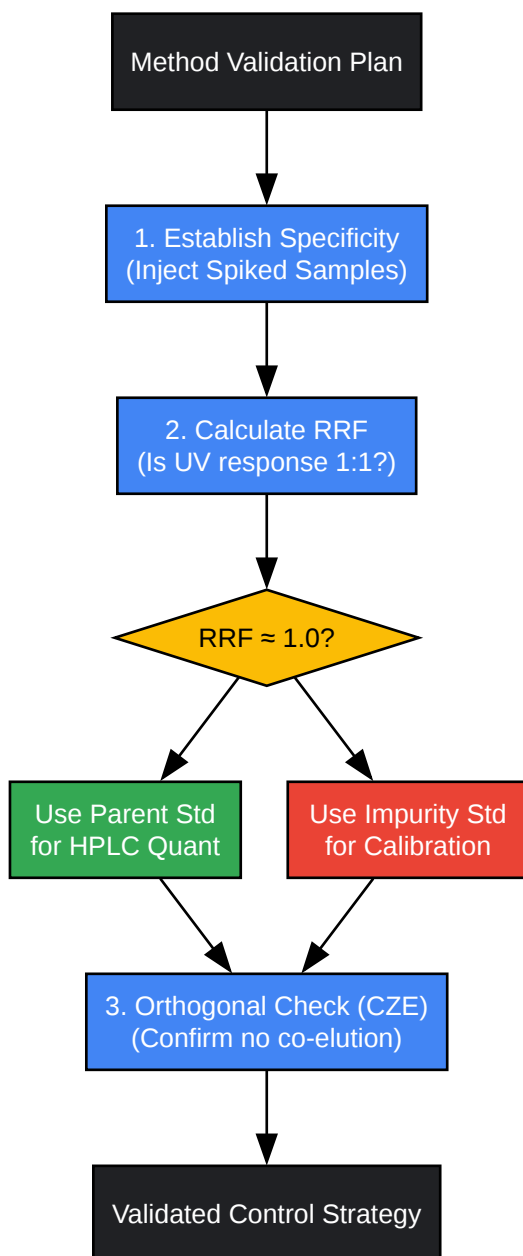

[Click to download full resolution via product page](#)

Figure 2: Decision tree for establishing a validated quantification strategy.

## References

- European Pharmacopoeia (Ph. Eur.). Octreotide Acetate Monograph 2414. (Defines Impurity I as N-Acetyl-Octreotide and sets limits).

- United States Pharmacopeia (USP). Octreotide Acetate: Impurities. (Lists [Phe(Ac)]<sup>1</sup>-Octreotide as a specified impurity).
- TLC Pharmaceutical Standards. Octreotide Impurity I (**N-Acetyl-Phe-Octreotide**) Reference Standard Data.
- Salami, M. et al. (2016). A capillary electrophoretic-mass spectrometric method for the assessment of octreotide stability under stress conditions. *Journal of Chromatography A*. (Establishes CZE conditions for Octreotide degradation products).
- Waters Corporation. Development of an effective LC-MS/MS Cleaning Validation Method for Synthetic Peptide Drug Substances. (Provides LC-MS protocols for peptide impurities).

#### Need Custom Synthesis?

BenchChem offers custom synthesis for rare earth carbides and specific isotopic labeling.

Email: [info@benchchem.com](mailto:info@benchchem.com) or [Request Quote Online](#).

## Sources

- [1. pdf.benchchem.com \[pdf.benchchem.com\]](https://pdf.benchchem.com)
- [2. waters.com \[waters.com\]](https://www.waters.com)
- To cite this document: BenchChem. [Cross-validation of N-Acetyl-Phe-Octreotide Detection Methods]. BenchChem, [2026]. [Online PDF]. Available at: [\[https://www.benchchem.com/product/b1574728/docs#cross-validation-of-n-acetyl-phe-octreotide-detection-methods\]](https://www.benchchem.com/product/b1574728/docs#cross-validation-of-n-acetyl-phe-octreotide-detection-methods)

### Disclaimer & Data Validity:

The information provided in this document is for Research Use Only (RUO) and is strictly not intended for diagnostic or therapeutic procedures. While BenchChem strives to provide accurate protocols, we make no warranties, express or implied, regarding the fitness of this product for every specific experimental setup.

**Technical Support:** The protocols provided are for reference purposes. Unsure if this reagent suits your experiment?

**Need Industrial/Bulk Grade?** [Request Custom Synthesis Quote](#)

## BenchChem

Our mission is to be the trusted global source of essential and advanced chemicals, empowering scientists and researchers to drive progress in science and industry.

### Contact

Address: 3281 E Guasti Rd  
Ontario, CA 91761, United States  
Phone: (601) 213-4426  
Email: [info@benchchem.com](mailto:info@benchchem.com)

[Contact our Ph.D. Support Team for a compatibility check](#)