

# Application Note: Avibactam Sodium Hydrate for Antimicrobial Susceptibility Testing (AST)

**Author:** BenchChem Technical Support Team. **Date:** April 2026

## Compound of Interest

Compound Name: Avibactam sodium hydrate

Cat. No.: B1574185

[Get Quote](#)

## Abstract

**Avibactam sodium hydrate** is a diazabicyclooctane (DBO) non-lactam

-lactamase inhibitor (BLI) that restores the activity of partner cephalosporins (e.g., ceftazidime) and monobactams against multidrug-resistant (MDR) Gram-negative bacteria. Unlike traditional BLIs (e.g., clavulanic acid), avibactam functions via a reversible covalent mechanism, inhibiting Class A, Class C, and specific Class D (e.g., OXA-48) enzymes.[1] This guide details the standardized protocols for handling **avibactam sodium hydrate** in Antimicrobial Susceptibility Testing (AST), specifically focusing on Broth Microdilution (BMD) methodologies where avibactam is maintained at a fixed concentration.

## Mechanistic Foundation[2]

To optimize AST protocols, researchers must understand the kinetic behavior of avibactam. Unlike "suicide inhibitors" that are permanently inactivated after binding, avibactam recycles itself.

## Mechanism of Action (MoA)

Avibactam covalently acylates the active-site serine of the

-lactamase. This reaction is reversible; the carbamoyl-enzyme complex eventually deacylates to release the intact inhibitor, allowing it to bind another enzyme molecule. This "recycling" capability is what drives its high potency against high-volume enzymes like KPC and AmpC.

## Pathway Visualization

The following diagram illustrates the reversible acylation cycle of Avibactam compared to the hydrolysis of a

-lactam antibiotic.

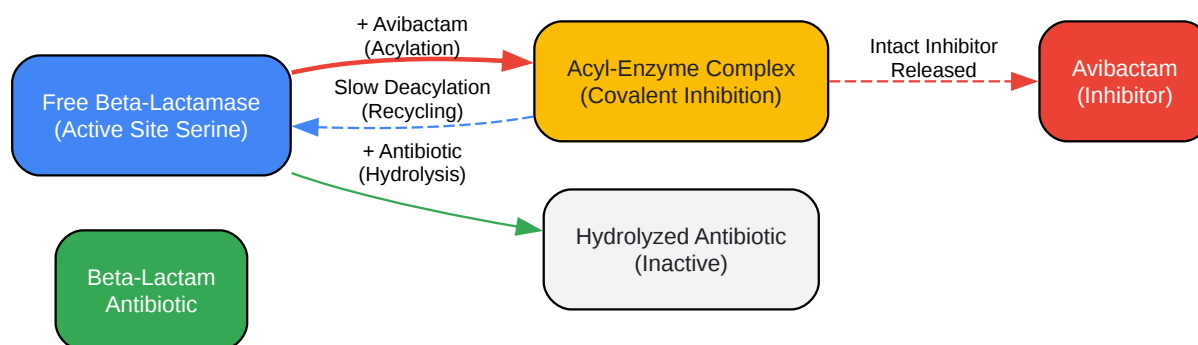

[Click to download full resolution via product page](#)

Figure 1: Kinetic cycle showing Avibactam's reversible inhibition versus antibiotic hydrolysis.

## Material Handling & Pre-Analytical Preparation[3][4]

The physical form of Avibactam is typically **Avibactam Sodium Hydrate**. Errors in stock preparation are the most common cause of AST failure.

## Chemical Properties

- Active Moiety: Avibactam (Free Acid)[2][3]
- Supplied Form: Sodium Salt, Hydrate
- Solubility: Highly soluble in water (>10 mg/mL); soluble in DMSO.

- **Stability:** Powder is stable at -20°C. Aqueous solutions are labile; prepare fresh or freeze immediately at -80°C.

## Calculation of Potency (Critical)

You must correct for the sodium ion and water content (hydrate) to determine the weight of the active moiety. Do not use the generic Molecular Weight (MW) from the bottle. Use the Potency provided on the specific Certificate of Analysis (CoA).

Formula:

If Potency is not listed, calculate it using the purity and MW ratio:

## Storage Protocol

State	Condition	Shelf Life
Powder	-20°C or -80°C, Desiccated	2 Years (Check CoA)
Stock Solution (>1 mg/mL)	-80°C	3-6 Months (Avoid Freeze-Thaw)
Working Solution	2-8°C	< 12 Hours (Discard after use)

## Experimental Protocol: Broth Microdilution (BMD)

Objective: Determine the MIC of a partner drug (e.g., Ceftazidime) in the presence of a fixed concentration of Avibactam. Standard: CLSI M07 / ISO 20776-1. Fixed Concentration: 4 µg/mL (Standard for Ceftazidime-Avibactam).<sup>[4][5][6]</sup>

## Reagents

- Cation-Adjusted Mueller-Hinton Broth (CAMHB): pH 7.2–7.4.
- Avibactam Stock: Prepared at 40x or 100x the final fixed concentration.
- Partner Drug (e.g., Ceftazidime): Prepared in serial dilutions.

## Workflow: The "Fixed Concentration" Method

Unlike standard MIC plates where the drug is diluted across the plate, Avibactam must remain constant in every well (except growth control).

#### Step-by-Step Procedure:

- Prepare Avibactam Working Solution:
  - Target Final Concentration: 4 µg/mL.
  - Prepare a 4x working solution: 16 µg/mL in CAMHB.
- Prepare Partner Drug Series (2x):
  - Prepare serial two-fold dilutions of Ceftazidime at 2x the desired final concentrations (e.g., 256 µg/mL down to 0.06 µg/mL).
- Plate Assembly (96-well plate):
  - Add 50 µL of 2x Partner Drug to columns 1–11.
  - Add 25 µL of 4x Avibactam (16 µg/mL) to columns 1–11.
  - Note: At this stage, volume is 75 µL.
- Inoculum Addition:
  - Prepare bacterial suspension to 0.5 McFarland.<sup>[4][7]</sup>
  - Dilute to reach  
CFU/mL (final well concentration).
  - Add 25 µL of Inoculum to all wells.
  - Final Volume: 100 µL.
  - Final Avibactam Conc:

## Workflow Diagram

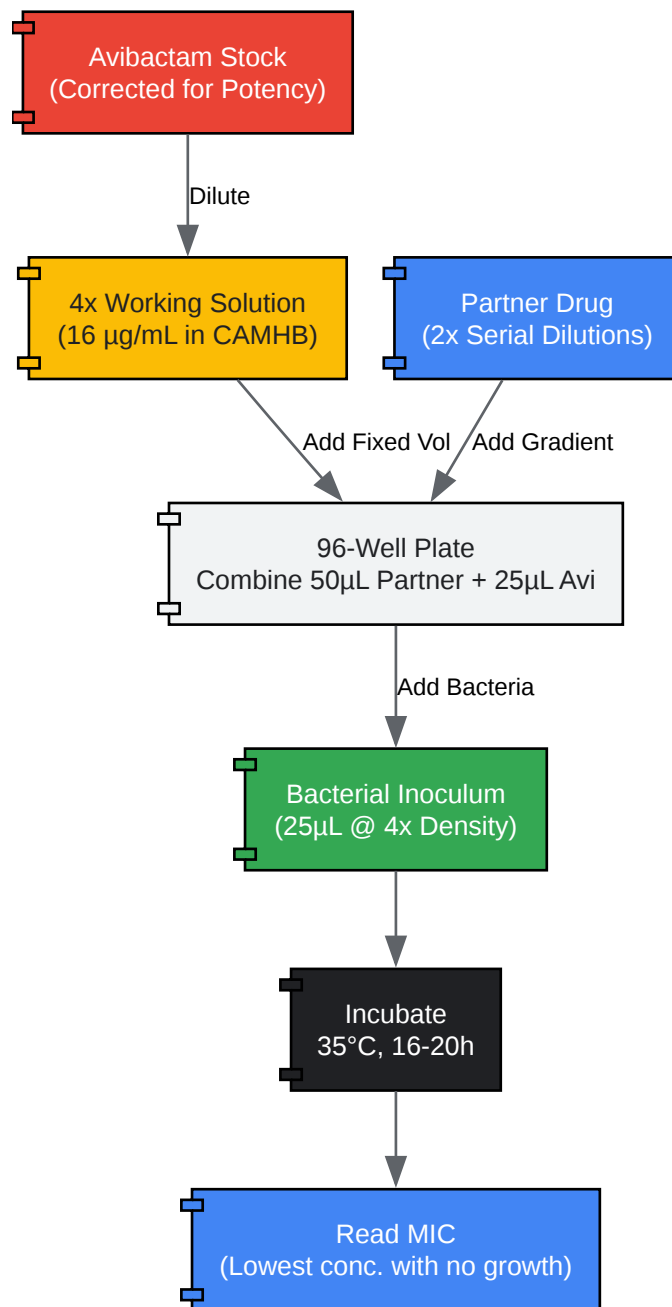

[Click to download full resolution via product page](#)

Figure 2: Step-by-step plate assembly for fixed-concentration inhibitor testing.

## Data Interpretation & Quality Control

Trustworthiness in AST data relies heavily on Quality Control (QC) strains. You must verify that the Avibactam is actually inhibiting

-lactamases.

## Quality Control Strains (CLSI M100)

For Ceftazidime-Avibactam (CZA), use the following controls. *K. pneumoniae* ATCC 700603 is the critical strain to verify Avibactam activity, as it produces an SHV-18 ESBL that confers resistance to Ceftazidime alone but is susceptible to the combination.

Organism	ATCC Strain	Resistance Mechanism	Ceftazidime MIC (µg/mL)	Ceftazidime-Avibactam MIC (µg/mL)
<i>K. pneumoniae</i>	700603	ESBL (SHV-18)	> 16 (R)	0.25 – 2.0
<i>E. coli</i>	25922	None (Susceptible)	0.06 – 0.5	0.06 – 0.5
<i>P. aeruginosa</i>	27853	Inducible AmpC	1 – 4	0.5 – 4.0
<i>K. pneumoniae</i>	BAA-1705	KPC-2 (Carbapenemase )	> 64	0.5 – 2.0

Note: All ranges assume Avibactam fixed at 4 µg/mL. [\[4\]](#)[\[5\]](#)[\[6\]](#)[\[8\]](#)

## Breakpoints (FDA/CLSI)

For Enterobacterales and *P. aeruginosa*:

- Susceptible (S):

8/4 µg/mL [\[9\]](#)[\[10\]](#)

- Resistant (R):

16/4 µg/mL [\[10\]](#)

## Troubleshooting & Optimization

Issue	Probable Cause	Corrective Action
QC Strain 700603 is Resistant	Avibactam degradation or omission.	Prepare fresh Avibactam stock. Ensure -80°C storage. Verify calculation (hydrate correction).
Skipped Wells	Pipetting error or contamination.	Check pipette calibration. Ensure sterile technique. Repeat assay.
Trailing Growth	Inoculum too high.	Verify 0.5 McFarland and subsequent dilution steps. Final well conc must be CFU/mL.
Unexpected Resistance in MBLs	Mechanism mismatch.	Avibactam does not inhibit Metallo- -lactamases (NDM, VIM, IMP). Confirm genotype.

## References

- Clinical and Laboratory Standards Institute (CLSI). (2023).[11] M100: Performance Standards for Antimicrobial Susceptibility Testing. 33rd Edition.[9][11]
- European Committee on Antimicrobial Susceptibility Testing (EUCAST). (2023).[11] Breakpoint tables for interpretation of MICs and zone diameters. Version 13.0.
- Ehmann, D. E., et al. (2012).[12] "Avibactam is a covalent, reversible, non- $\beta$ -lactamase inhibitor." [1][12][13][14][15] Proceedings of the National Academy of Sciences, 109(29), 11663-11668.
- Nichols, W. W., et al. (2016). "Avibactam Pharmacokinetic/Pharmacodynamic Targets." Antimicrobial Agents and Chemotherapy, 60(10).

- PubChem. (2023). **Avibactam Sodium Hydrate** Compound Summary. National Library of Medicine.

### Need Custom Synthesis?

BenchChem offers custom synthesis for rare earth carbides and specific isotopic labeling.

Email: [info@benchchem.com](mailto:info@benchchem.com) or [Request Quote Online](#).

## Sources

- [1. taylorandfrancis.com](https://taylorandfrancis.com) [[taylorandfrancis.com](https://taylorandfrancis.com)]
- [2. acs.org](https://acs.org) [[acs.org](https://acs.org)]
- [3. AvibactaM | 1192500-31-4](https://chemicalbook.com) [[chemicalbook.com](https://chemicalbook.com)]
- [4. liofilchem.net](https://liofilchem.net) [[liofilchem.net](https://liofilchem.net)]
- [5. journals.asm.org](https://journals.asm.org) [[journals.asm.org](https://journals.asm.org)]
- [6. A Systematic Approach to the Selection of the Appropriate Avibactam Concentration for Use with Ceftazidime in Broth Microdilution Susceptibility Testing - PMC](https://pubmed.ncbi.nlm.nih.gov/36888888/) [[pmc.ncbi.nlm.nih.gov](https://pubmed.ncbi.nlm.nih.gov/36888888/)]
- [7. fwdamr-reflabcap.eu](https://www.fwdamr-reflabcap.eu) [[fwdamr-reflabcap.eu](https://www.fwdamr-reflabcap.eu)]
- [8. accessdata.fda.gov](https://accessdata.fda.gov) [[accessdata.fda.gov](https://accessdata.fda.gov)]
- [9. Antimicrobial Susceptibility of Ceftazidime-Avibactam in Clinical Isolates of Carbapenemase-Producing Enterobacterales - PMC](https://pubmed.ncbi.nlm.nih.gov/36888888/) [[pmc.ncbi.nlm.nih.gov](https://pubmed.ncbi.nlm.nih.gov/36888888/)]
- [10. clsi.org](https://clsi.org) [[clsi.org](https://clsi.org)]
- [11. szu.gov.cz](https://szu.gov.cz) [[szu.gov.cz](https://szu.gov.cz)]
- [12. Frontiers | Biochemical exploration of  \$\beta\$ -lactamase inhibitors](https://frontiersin.org) [[frontiersin.org](https://frontiersin.org)]
- [13. journals.asm.org](https://journals.asm.org) [[journals.asm.org](https://journals.asm.org)]
- [14. Avibactam is a covalent, reversible, non- \$\beta\$ -lactam  \$\beta\$ -lactamase inhibitor - PMC](https://pubmed.ncbi.nlm.nih.gov/36888888/) [[pmc.ncbi.nlm.nih.gov](https://pubmed.ncbi.nlm.nih.gov/36888888/)]
- [15. Avibactam and Class C  \$\beta\$ -Lactamases: Mechanism of Inhibition, Conservation of the Binding Pocket, and Implications for Resistance - PMC](https://pubmed.ncbi.nlm.nih.gov/36888888/) [[pmc.ncbi.nlm.nih.gov](https://pubmed.ncbi.nlm.nih.gov/36888888/)]
- To cite this document: BenchChem. [Application Note: Avibactam Sodium Hydrate for Antimicrobial Susceptibility Testing (AST)]. BenchChem, [2026]. [Online PDF]. Available at:

[<https://www.benchchem.com/product/b1574185/docs#application-note-avibactam-sodium-hydrate-for-antimicrobial-susceptibility-testing-ast>]

### Disclaimer & Data Validity:

The information provided in this document is for Research Use Only (RUO) and is strictly not intended for diagnostic or therapeutic procedures. While BenchChem strives to provide accurate protocols, we make no warranties, express or implied, regarding the fitness of this product for every specific experimental setup.

**Technical Support:** The protocols provided are for reference purposes. Unsure if this reagent suits your experiment?

**Need Industrial/Bulk Grade?** [Request Custom Synthesis Quote](#)

## BenchChem

Our mission is to be the trusted global source of essential and advanced chemicals, empowering scientists and researchers to drive progress in science and industry.

### Contact

Address: 3281 E Guasti Rd  
Ontario, CA 91761, United States  
Phone: (601) 213-4426  
Email: [info@benchchem.com](mailto:info@benchchem.com)

[Contact our Ph.D. Support Team for a compatibility check](#)