

A Comparative Analysis of SU11657 and Crizotinib in Lung Cancer Cells

Author: BenchChem Technical Support Team. **Date:** December 2025

Compound of Interest

Compound Name: SU11657

Cat. No.: B1574702

[Get Quote](#)

For Immediate Publication

[City, State] – [Date] – In the landscape of targeted therapies for non-small cell lung cancer (NSCLC), a detailed understanding of the comparative efficacy and mechanisms of action of various inhibitors is crucial for advancing drug development and clinical application. This report provides a comprehensive comparison of two notable tyrosine kinase inhibitors, **SU11657** and crizotinib, with a focus on their performance in lung cancer cell lines.

Introduction to the Inhibitors

SU11657 (also known as SU11274) is a selective inhibitor of the c-Met receptor tyrosine kinase.[1] The c-Met pathway, when aberrantly activated, plays a significant role in tumor growth, invasion, and metastasis. Crizotinib, on the other hand, is a multi-targeted tyrosine kinase inhibitor that acts on anaplastic lymphoma kinase (ALK), ROS1, and c-Met.[2][3] It is an FDA-approved therapeutic for patients with ALK-positive NSCLC.[2]

Mechanism of Action and Cellular Effects

SU11657 primarily exerts its anti-cancer effects by selectively targeting the c-Met receptor. In cell-free assays, it demonstrates a potent inhibitory concentration (IC50) of 10 nM against c-Met.[1] In c-Met-expressing NSCLC cells, **SU11657** has been shown to inhibit cell viability with IC50 values ranging from 0.8 to 4.4 μ M.[1] Mechanistically, it abrogates hepatocyte growth factor (HGF)-induced phosphorylation of c-Met and its downstream signaling pathways.[1][4] This inhibition leads to significant cellular consequences, including G1 phase cell cycle arrest

and the induction of caspase-dependent apoptosis.[1] Furthermore, studies have indicated that **SU11657**'s therapeutic effect in lung cancer cells with wild-type p53 is mediated through the p53-dependent apoptotic pathway, involving the regulation of PUMA, Bax, and Bcl-2, and the activation of caspases.[5]

Crizotinib's primary mechanism in ALK-positive NSCLC involves the inhibition of ALK expression, which in turn leads to a decrease in cell proliferation and an increase in apoptosis. [2] As a multi-targeted inhibitor, it also demonstrates activity against the c-Met receptor. This dual inhibition is significant as the c-Met signaling pathway can be a mechanism of resistance to other targeted therapies. While specific IC50 values for crizotinib's anti-proliferative effects in a wide range of NSCLC cell lines are not readily available in a single comprehensive source, its clinical efficacy in ALK-positive NSCLC is well-established, with high response rates observed in clinical trials.[3] Resistance to crizotinib can develop through secondary mutations in the ALK kinase domain or the activation of alternative signaling pathways.[3]

Quantitative Data Summary

The following table summarizes the available quantitative data for **SU11657** and crizotinib, providing a comparative overview of their inhibitory concentrations.

Inhibitor	Target	Assay Type	Cell Line(s)	IC50 Value	Reference(s)
SU11657	c-Met	Cell-free	-	10 nM	[1]
Cell Viability	c-Met-expressing NSCLC	Multiple	0.8 - 4.4 μ M	[1]	
HGF-induced cell growth	H69 (SCLC)	SCLC	3.4 μ M	[1]	
HGF-induced cell growth	H345 (SCLC)	SCLC	6.5 μ M	[1]	
Crizotinib	ALK, ROS1, c-Met	Clinical Trials	ALK-positive NSCLC	N/A (Clinical Efficacy)	[2][3]

Signaling Pathway Diagrams

To visualize the mechanisms of action, the following diagrams illustrate the signaling pathways affected by **SU11657** and crizotinib.

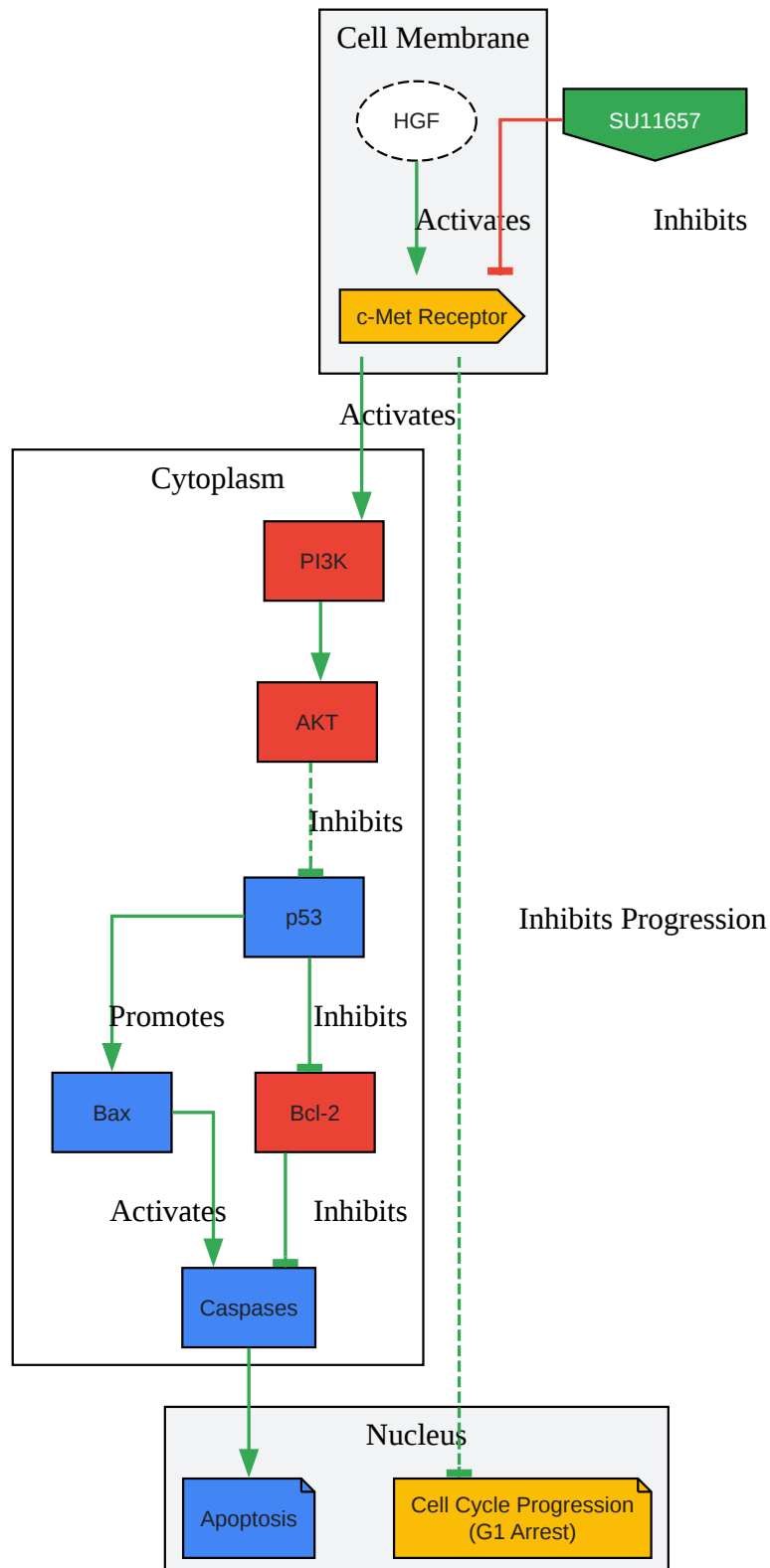

[Click to download full resolution via product page](#)

Caption: **SU11657** inhibits c-Met signaling, leading to G1 cell cycle arrest and p53-mediated apoptosis.

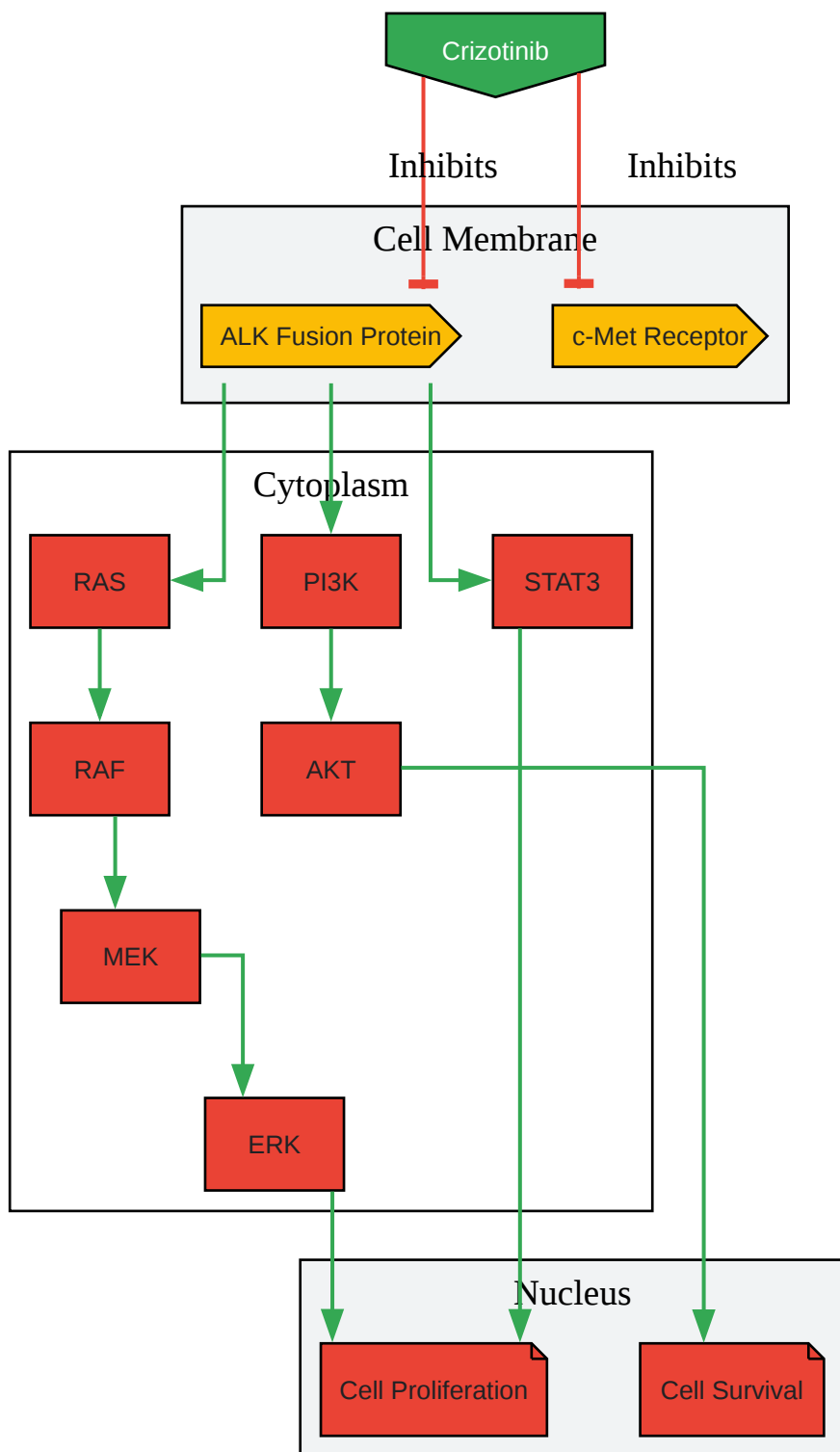

[Click to download full resolution via product page](#)

Caption: Crizotinib inhibits the ALK fusion protein and c-Met, blocking downstream proliferative and survival pathways.

Experimental Protocols

Detailed methodologies for key experiments are provided below to ensure reproducibility and aid in the design of future studies.

Cell Viability Assay (MTT Assay)

Objective: To determine the cytotoxic effects of **SU11657** and crizotinib on lung cancer cell lines.

Materials:

- Lung cancer cell lines (e.g., A549, H1975, H460)
- Complete growth medium (e.g., RPMI-1640 with 10% FBS)
- 96-well plates
- **SU11657** and Crizotinib stock solutions (dissolved in DMSO)
- MTT (3-(4,5-dimethylthiazol-2-yl)-2,5-diphenyltetrazolium bromide) solution (5 mg/mL in PBS)
- Solubilization solution (e.g., DMSO or 0.01 M HCl in 10% SDS)
- Microplate reader

Procedure:

- Cell Seeding: Seed lung cancer cells into 96-well plates at a density of 5,000-10,000 cells per well in 100 μ L of complete growth medium. Incubate overnight at 37°C in a humidified 5% CO₂ incubator to allow for cell attachment.
- Drug Treatment: Prepare serial dilutions of **SU11657** and crizotinib in complete growth medium. Remove the medium from the wells and add 100 μ L of the drug dilutions. Include a

vehicle control (medium with DMSO at the same concentration as the highest drug concentration).

- Incubation: Incubate the plates for 48-72 hours at 37°C and 5% CO₂.
- MTT Addition: After the incubation period, add 20 µL of MTT solution to each well and incubate for an additional 2-4 hours at 37°C.
- Solubilization: Carefully remove the medium containing MTT. Add 150 µL of the solubilization solution to each well to dissolve the formazan crystals.
- Absorbance Measurement: Measure the absorbance at 570 nm using a microplate reader.
- Data Analysis: Calculate the percentage of cell viability relative to the vehicle control. The IC₅₀ value, the concentration of the drug that inhibits cell growth by 50%, can be determined by plotting the percentage of viability against the drug concentration and fitting the data to a dose-response curve.

Western Blotting

Objective: To analyze the effect of **SU11657** and crizotinib on the phosphorylation status and expression levels of key proteins in relevant signaling pathways.

Materials:

- Lung cancer cell lines
- **SU11657** and Crizotinib
- Lysis buffer (e.g., RIPA buffer) with protease and phosphatase inhibitors
- Protein assay kit (e.g., BCA assay)
- SDS-PAGE gels
- Transfer apparatus and membranes (e.g., PVDF or nitrocellulose)
- Blocking buffer (e.g., 5% non-fat milk or BSA in TBST)

- Primary antibodies (e.g., anti-p-Met, anti-Met, anti-p-AKT, anti-AKT, anti-p-ERK, anti-ERK, anti-p53, anti-Bax, anti-Bcl-2, anti-GAPDH)
- HRP-conjugated secondary antibodies
- Chemiluminescent substrate
- Imaging system

Procedure:

- Cell Treatment and Lysis: Plate cells and treat with **SU11657** or crizotinib at the desired concentrations and for the specified time. After treatment, wash the cells with ice-cold PBS and lyse them with lysis buffer.
- Protein Quantification: Determine the protein concentration of the cell lysates using a protein assay kit.
- SDS-PAGE and Transfer: Denature equal amounts of protein from each sample by boiling in Laemmli buffer. Separate the proteins by SDS-PAGE and transfer them to a membrane.
- Blocking and Antibody Incubation: Block the membrane with blocking buffer for 1 hour at room temperature. Incubate the membrane with the primary antibody overnight at 4°C.
- Secondary Antibody and Detection: Wash the membrane with TBST and incubate with the appropriate HRP-conjugated secondary antibody for 1 hour at room temperature. After further washes, add the chemiluminescent substrate and visualize the protein bands using an imaging system.
- Analysis: Quantify the band intensities and normalize to a loading control (e.g., GAPDH) to determine the relative changes in protein expression and phosphorylation.

Conclusion

This comparative guide provides a foundational overview of **SU11657** and crizotinib in the context of lung cancer cells. **SU11657** emerges as a potent and selective c-Met inhibitor with clear mechanisms of inducing cell cycle arrest and apoptosis. Crizotinib, a clinically validated drug, demonstrates broader activity by targeting multiple kinases, including ALK and c-Met. The

provided data and protocols offer a valuable resource for researchers in the field, facilitating further investigation into the therapeutic potential of these and other targeted inhibitors in the fight against lung cancer.

Need Custom Synthesis?

BenchChem offers custom synthesis for rare earth carbides and specific isotopic labeling.

Email: info@benchchem.com or [Request Quote Online](#).

References

- 1. selleckchem.com [selleckchem.com]
- 2. go.drugbank.com [go.drugbank.com]
- 3. m.youtube.com [m.youtube.com]
- 4. aacrjournals.org [aacrjournals.org]
- 5. The Blocking of c-Met Signaling Induces Apoptosis through the Increase of p53 Protein in Lung Cancer [e-crt.org]
- To cite this document: BenchChem. [A Comparative Analysis of SU11657 and Crizotinib in Lung Cancer Cells]. BenchChem, [2025]. [Online PDF]. Available at: [https://www.benchchem.com/product/b1574702#su11657-vs-crizotinib-in-lung-cancer-cells]

Disclaimer & Data Validity:

The information provided in this document is for Research Use Only (RUO) and is strictly not intended for diagnostic or therapeutic procedures. While BenchChem strives to provide accurate protocols, we make no warranties, express or implied, regarding the fitness of this product for every specific experimental setup.

Technical Support: The protocols provided are for reference purposes. Unsure if this reagent suits your experiment? [[Contact our Ph.D. Support Team for a compatibility check](#)]

Need Industrial/Bulk Grade? [Request Custom Synthesis Quote](#)

BenchChem

Our mission is to be the trusted global source of essential and advanced chemicals, empowering scientists and researchers to drive progress in science and industry.

Contact

Address: 3281 E Guasti Rd

Ontario, CA 91761, United States

Phone: (601) 213-4426

Email: info@benchchem.com