

Application and Protocol Guide for the Quantification of Neodymium Trinitrate

Author: BenchChem Technical Support Team. **Date:** May 2026

Compound of Interest

Compound Name: Neodymium trinitrate

CAS No.: 10045-95-1

Cat. No.: B157462

[Get Quote](#)

Abstract

This comprehensive guide provides detailed application notes and validated protocols for the accurate quantification of Neodymium (III) Trinitrate, a compound of significant interest in materials science, catalysis, and various high-technology sectors. Addressing the distinct analytical requirements for both the neodymium cation and the nitrate anion, this document outlines several robust analytical techniques. For the determination of neodymium, methodologies including Inductively Coupled Plasma - Optical Emission Spectrometry (ICP-OES), Inductively Coupled Plasma - Mass Spectrometry (ICP-MS), UV-Visible (UV-Vis) Spectroscopy, and Complexometric Titration are presented. For the quantification of the nitrate counter-ion, Ion Chromatography (IC) is detailed. Each protocol is designed to be a self-validating system, with an emphasis on the scientific rationale behind experimental choices to ensure data integrity and reproducibility. This guide is intended for researchers, scientists, and professionals in drug development and quality control who require precise and reliable methods for the characterization of neodymium-containing compounds.

Introduction: The Analytical Imperative for Neodymium Trinitrate

Neodymium, a member of the lanthanide series of rare earth elements, is a critical component in numerous advanced technologies, including high-strength permanent magnets, lasers, and specialized glass manufacturing.[1] **Neodymium trinitrate**, often in its hexahydrate form $[\text{Nd}(\text{NO}_3)_3 \cdot 6\text{H}_2\text{O}]$, serves as a common precursor for the synthesis of neodymium oxide and other neodymium-containing materials.[2][3][4] The precise quantification of both neodymium and nitrate in this salt is paramount for stoichiometric control in synthesis, quality assurance of starting materials, and for understanding the behavior of these species in various chemical and biological systems.

This guide provides a selection of validated analytical techniques, ranging from high-throughput spectrometric methods to classical titrimetry, to offer a versatile toolkit for the comprehensive analysis of **neodymium trinitrate**. The choice of method will depend on factors such as the required sensitivity, sample matrix complexity, available instrumentation, and the desired analytical throughput.

Quantification of Neodymium (Nd^{3+}) Inductively Coupled Plasma - Optical Emission Spectrometry (ICP-OES)

Principle of Operation: ICP-OES is a powerful technique for the determination of elemental composition.[5] A liquid sample is introduced into a high-temperature argon plasma (typically 6,000-10,000 K), which desolvates, atomizes, and excites the neodymium atoms. As the excited atoms relax to their ground state, they emit photons at characteristic wavelengths. The intensity of this emitted light is directly proportional to the concentration of neodymium in the sample. High-resolution optical systems are crucial for resolving the emission lines of neodymium from potential spectral interferences, especially from other rare earth elements.[6] [7]

Advantages:

- High sensitivity and a wide linear dynamic range.

- Robustness and high matrix tolerance.[6]
- Relatively fast analysis time.

Limitations:

- Potential for spectral interferences from other elements in complex matrices.[6]
- Requires sample dissolution into a liquid form.
- Sample Preparation:
 - Accurately weigh a sample of **neodymium trinitrate** and dissolve it in a known volume of 1-2% nitric acid (HNO₃) in deionized water. The final concentration should be within the linear range of the instrument. A typical working range for neodymium is 0.1 to 10 mg/L.[6][8]
- Instrumentation and Parameters:
 - Instrument: A high-resolution ICP-OES system is recommended.[6][7]
 - Plasma Conditions: Optimize the plasma gas flow, auxiliary gas flow, and nebulizer gas flow to ensure stable plasma and efficient sample introduction.
 - Wavelength Selection: Monitor the following interference-free emission wavelengths for neodymium: 401.225 nm, 410.946 nm, and 430.367 nm.[9]
- Calibration:
 - Prepare a series of calibration standards (e.g., 0.1, 0.5, 1.0, 5.0, and 10.0 mg/L) by diluting a certified neodymium standard solution in the same 1-2% HNO₃ matrix as the samples.
 - Generate a calibration curve by plotting the emission intensity versus the concentration of the standards. A linear regression with a correlation coefficient (r^2) > 0.999 is desirable.
- Analysis and Data Processing:

- Aspirate the prepared sample solution into the ICP-OES.
- The instrument software will automatically calculate the neodymium concentration in the sample based on the calibration curve.
- Report the final concentration, taking into account the initial sample weight and dilution factor.

Data Presentation:

Parameter	Typical Value
Wavelengths	401.225 nm, 410.946 nm[9]
Detection Limit	sub- μ g/L to low mg/L
Linearity (r^2)	> 0.999
Precision (RSD)	< 2%[8]

Experimental Workflow:

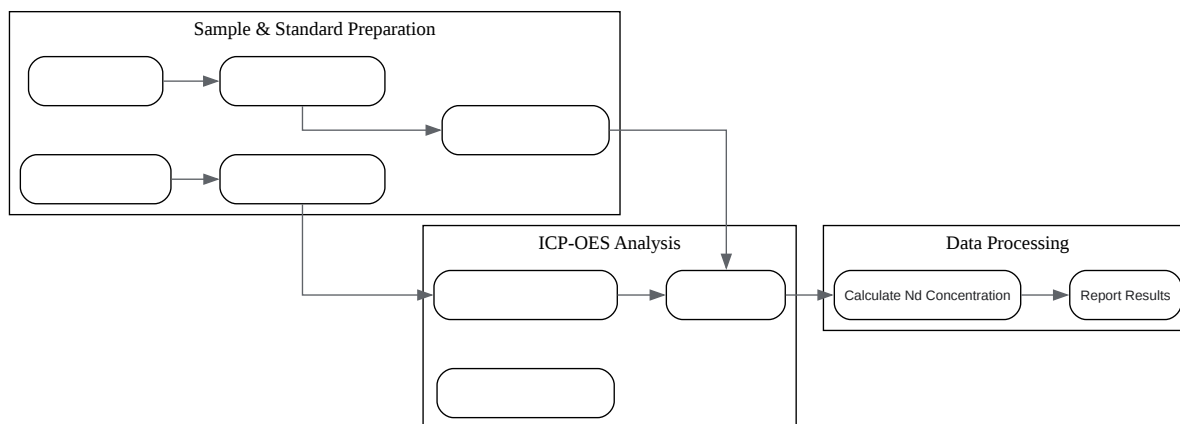

[Click to download full resolution via product page](#)

Caption: Workflow for Neodymium quantification by ICP-OES.

Inductively Coupled Plasma - Mass Spectrometry (ICP-MS)

Principle of Operation: ICP-MS offers even lower detection limits than ICP-OES by using a mass spectrometer to detect the ions produced in the argon plasma.^[10] The ions are extracted from the plasma and guided through a series of lenses into a mass analyzer (e.g., a quadrupole), which separates them based on their mass-to-charge ratio (m/z). ICP-MS is particularly well-suited for trace and ultra-trace analysis of rare earth elements.^{[6][11][12]} However, it is susceptible to polyatomic and isobaric interferences, which can be mitigated using collision/reaction cell technology.^{[6][10]}

Advantages:

- Extremely high sensitivity, with detection limits in the ng/L (ppt) to pg/L (ppq) range.^{[6][10]}

- Isotopic analysis capabilities.

Limitations:

- More susceptible to matrix effects than ICP-OES.[6]
- Higher operational costs and complexity.
- Potential for isobaric and polyatomic interferences.[6][10]
- Sample Preparation:
 - Follow the same dissolution procedure as for ICP-OES, but dilute the sample to a much lower concentration, typically in the $\mu\text{g/L}$ (ppb) range. The use of an internal standard (e.g., Rhodium) is highly recommended to correct for instrumental drift and matrix effects. [11]
- Instrumentation and Parameters:
 - Instrument: An ICP-MS system, preferably equipped with a collision/reaction cell.
 - Monitored Isotopes: ^{142}Nd , ^{143}Nd , ^{144}Nd , ^{145}Nd , ^{146}Nd .
 - Collision/Reaction Gas: Helium or hydrogen can be used to reduce polyatomic interferences.[8]
- Calibration:
 - Prepare calibration standards in the range of 0.1 to 100 $\mu\text{g/L}$ by diluting a certified neodymium standard solution in 1-2% HNO_3 . Ensure the internal standard is added to all standards and samples at a constant concentration.
- Analysis and Data Processing:
 - Introduce the samples and standards into the ICP-MS.
 - The concentration of neodymium is determined by comparing the signal intensity of the neodymium isotopes in the sample to the calibration curve, after normalization with the

internal standard.

Data Presentation:

Parameter	Typical Value
Monitored Isotopes	^{143}Nd , ^{145}Nd , ^{146}Nd
Detection Limit	ng/L (ppt) or lower[10]
Linearity (r^2)	> 0.999
Precision (RSD)	< 3%

Experimental Workflow:

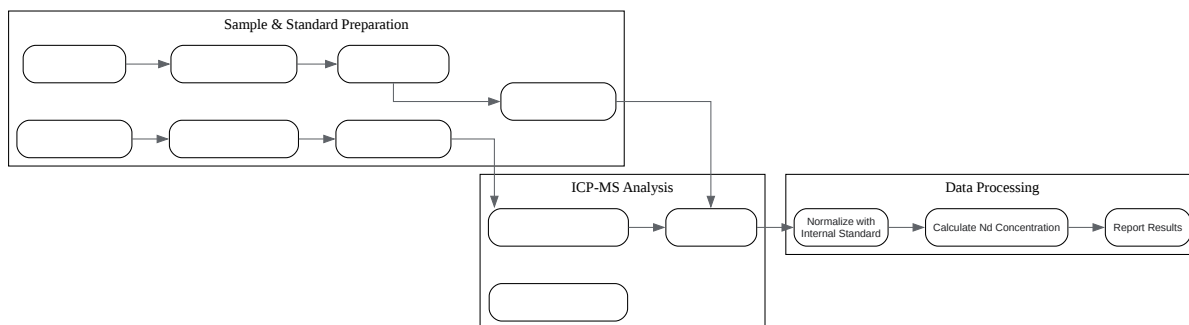

[Click to download full resolution via product page](#)

Caption: Workflow for Neodymium quantification by ICP-MS.

UV-Visible (UV-Vis) Spectroscopy

Principle of Operation: Neodymium ions (Nd^{3+}) in solution exhibit characteristic sharp absorption bands in the visible and near-infrared regions of the electromagnetic spectrum due to f-f electronic transitions.[13][14] According to the Beer-Lambert Law, the absorbance at a specific wavelength is directly proportional to the concentration of the absorbing species. This technique is less sensitive than ICP methods but is simple, cost-effective, and non-destructive. [15]

Advantages:

- Simple and rapid analysis.[15]
- Cost-effective instrumentation.[15]
- Non-destructive.[15]

Limitations:

- Lower sensitivity compared to ICP techniques.
- Potential for interference from other colored ions or complexing agents.[14]
- Sample Preparation:
 - Dissolve a precisely weighed amount of **neodymium trinitrate** in deionized water or a dilute acid solution (e.g., 0.1 M HClO_4) to a known volume. The concentration should be high enough to produce a measurable absorbance, typically in the g/L range.
- Instrumentation and Parameters:
 - Instrument: A double-beam UV-Vis spectrophotometer.
 - Wavelength Range: Scan from 300 nm to 900 nm to observe the characteristic absorption spectrum of Nd^{3+} .
 - Analytical Wavelengths: The absorption bands at 521 nm, 575 nm, 740 nm, and 798 nm are suitable for quantification.[13]

- Calibration:
 - Prepare a series of standards of known **neodymium trinitrate** concentration in the same solvent as the sample.
 - Measure the absorbance of each standard at the chosen analytical wavelength.
 - Construct a calibration curve by plotting absorbance versus concentration.
- Analysis and Data Processing:
 - Measure the absorbance of the sample solution at the same wavelength.
 - Determine the concentration of neodymium in the sample from the calibration curve.

Data Presentation:

Parameter	Typical Value
Analytical Wavelengths	521 nm, 575 nm, 798 nm ^[13]
Detection Limit	~0.5 mg ^[13]
Linearity (r^2)	> 0.99
Precision (RSD)	< 5%

Logical Relationship Diagram:

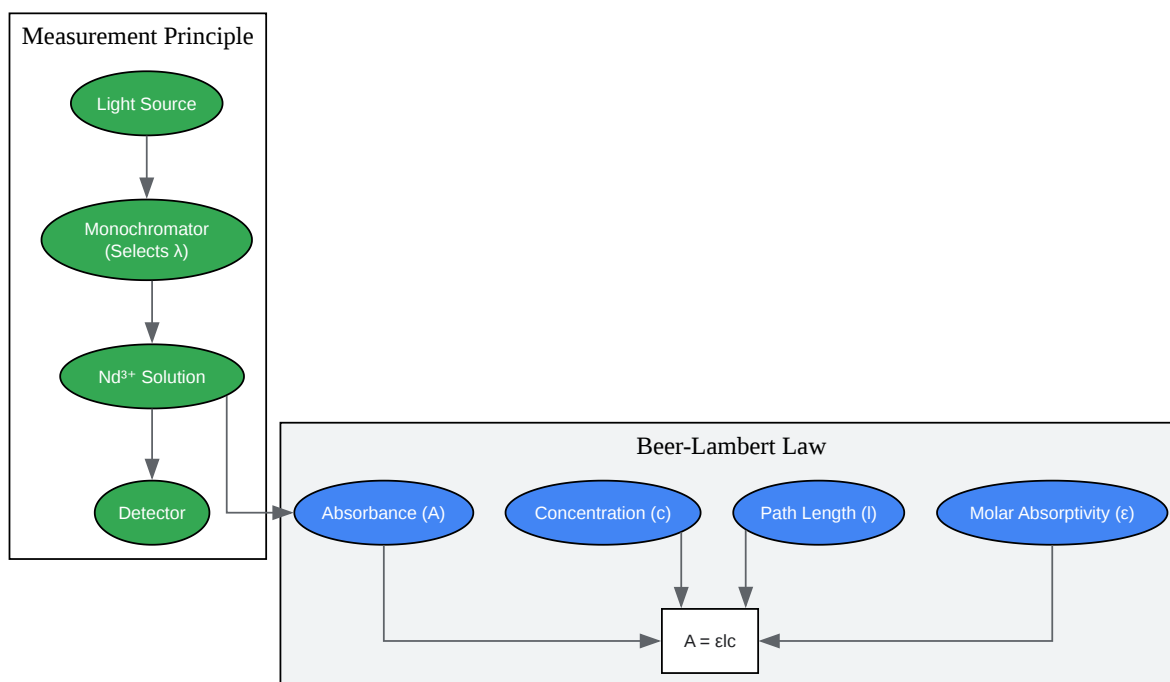

[Click to download full resolution via product page](#)

Caption: Principle of UV-Vis quantification based on the Beer-Lambert Law.

Complexometric Titration

Principle of Operation: This classical analytical method involves the titration of Nd³⁺ with a standard solution of a complexing agent, most commonly ethylenediaminetetraacetic acid (EDTA).^{[16][17]} EDTA forms a stable 1:1 complex with neodymium ions. The endpoint of the titration is detected using a metallochromic indicator, which changes color when it is displaced from the metal ion by EDTA. The pH of the solution must be carefully controlled to ensure the quantitative formation of the Nd-EDTA complex.

Advantages:

- High precision and accuracy when performed correctly.
- Low cost of instrumentation.

Limitations:

- Less sensitive than instrumental methods.
- Can be time-consuming.
- Lack of selectivity; other metal ions that form stable EDTA complexes will interfere.[18][19]
- Reagent Preparation:
 - Standard EDTA Solution (0.05 M): Dissolve a known mass of disodium EDTA dihydrate in deionized water. Standardize this solution against a primary standard calcium carbonate or zinc solution.
 - Buffer Solution (pH 5.5): Prepare an acetate buffer or use hexamethylenetetramine.
 - Indicator: Xylenol Orange indicator solution.
- Sample Preparation:
 - Accurately weigh a sample of **neodymium trinitrate**, dissolve it in deionized water, and dilute to a known volume.
- Titration Procedure:
 - Pipette a known aliquot of the sample solution into an Erlenmeyer flask.
 - Add the buffer solution to adjust the pH to approximately 5.5.
 - Add a few drops of Xylenol Orange indicator. The solution should turn red or violet.
 - Titrate with the standardized EDTA solution until the color changes from red/violet to a clear yellow at the endpoint.
- Calculation:

- Calculate the moles of EDTA used to reach the endpoint.
- Since the stoichiometry of the Nd-EDTA complex is 1:1, the moles of EDTA are equal to the moles of neodymium in the aliquot.
- From this, calculate the concentration and purity of the original **neodymium trinitrate** sample.

Logical Relationship Diagram:

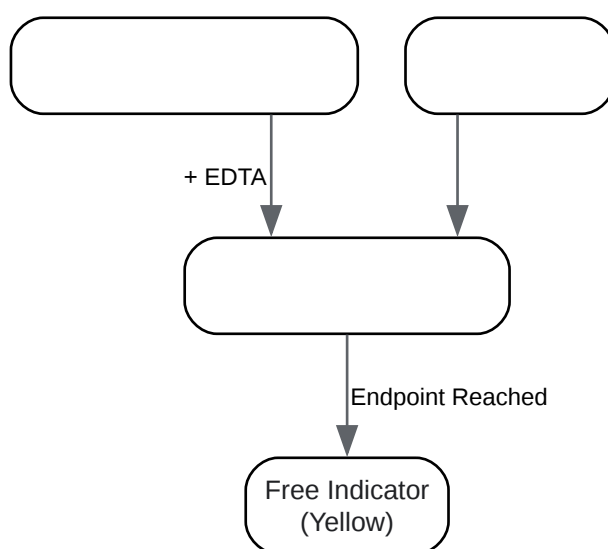

[Click to download full resolution via product page](#)

Caption: Principle of complexometric titration of Neodymium with EDTA.

Quantification of Nitrate (NO_3^-) Ion Chromatography (IC)

Principle of Operation: Ion chromatography is a form of liquid chromatography used for the separation and quantification of ionic species.[20] A liquid sample is injected into a stream of eluent (mobile phase) and passed through a column packed with an ion-exchange resin (stationary phase). The nitrate anions are separated from other anions based on their affinity for the stationary phase. A suppressor is typically used to reduce the background conductivity of the eluent, thereby increasing the sensitivity of detection by a conductivity detector. UV detection is also a viable option for nitrate.[21][22]

Advantages:

- High selectivity for different anions.
- Simultaneous determination of multiple anions.[23]
- Good sensitivity and precision.

Limitations:

- Requires specialized instrumentation.
- High concentrations of other anions (e.g., chloride) can interfere with the separation.
- Sample Preparation:
 - Accurately weigh a sample of **neodymium trinitrate** and dissolve it in a known volume of deionized water.
 - Dilute the sample to a concentration within the working range of the instrument (typically low mg/L for nitrate).
 - Filter the sample through a 0.45 µm syringe filter before injection.
- Instrumentation and Parameters:
 - Instrument: An ion chromatograph equipped with a guard column, an anion-exchange analytical column, a suppressor, and a conductivity detector.
 - Eluent: A carbonate/bicarbonate buffer is commonly used.
 - Flow Rate: Typically 1.0-1.5 mL/min.
- Calibration:
 - Prepare a series of calibration standards (e.g., 1, 5, 10, 20, 50 mg/L) from a certified nitrate standard solution.

- Generate a calibration curve by plotting the peak area versus the concentration of the standards.
- Analysis and Data Processing:
 - Inject the prepared sample into the IC system.
 - Identify the nitrate peak based on its retention time compared to the standards.
 - Quantify the nitrate concentration in the sample using the calibration curve.

Data Presentation:

Parameter	Typical Value
Column	Anion-exchange (e.g., Dionex IonPac AS11-HC) [20]
Detector	Suppressed Conductivity
Detection Limit	µg/L to low mg/L
Linearity (r^2)	> 0.999
Precision (RSD)	< 2%

Experimental Workflow:

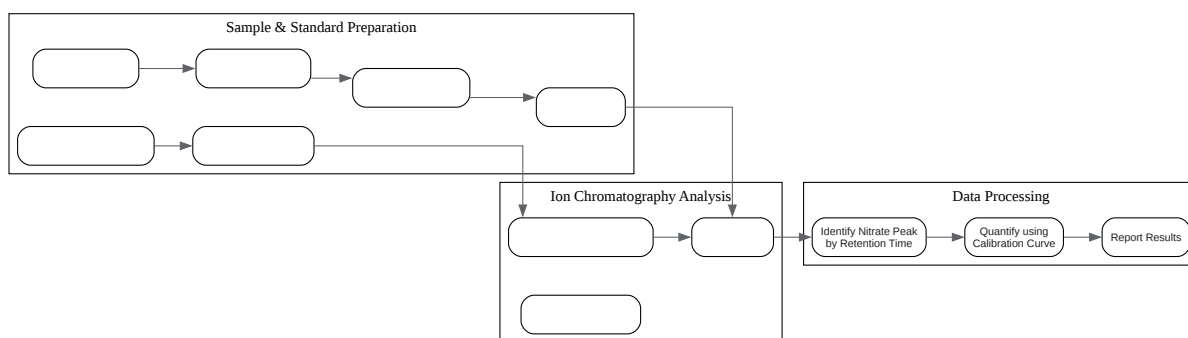

[Click to download full resolution via product page](#)

Caption: Workflow for Nitrate quantification by Ion Chromatography.

Method Validation and Quality Control

For all the described analytical methods, a proper validation is essential to ensure the reliability of the results.[24] Key validation parameters to be assessed include:

- **Specificity/Selectivity:** The ability of the method to accurately measure the analyte in the presence of other components in the sample matrix.
- **Linearity and Range:** The concentration range over which the method provides results that are directly proportional to the concentration of the analyte.
- **Accuracy:** The closeness of the measured value to the true value, often assessed by analyzing a certified reference material (CRM) or by spike recovery experiments.

- Precision: The degree of agreement among individual test results when the procedure is applied repeatedly to multiple samplings of a homogeneous sample. This is typically expressed as the relative standard deviation (RSD).
- Limit of Detection (LOD) and Limit of Quantitation (LOQ): The lowest concentration of the analyte that can be reliably detected and quantified, respectively.

Regular analysis of quality control (QC) samples, including blanks, calibration verification standards, and spiked samples, should be integrated into the analytical workflow to monitor the performance of the method over time.

Conclusion

The quantification of **neodymium trinitrate** can be effectively achieved through a variety of analytical techniques. For neodymium, ICP-OES and ICP-MS offer high sensitivity and are ideal for trace analysis, while UV-Vis spectroscopy and complexometric titration provide cost-effective alternatives for the analysis of higher concentrations. For the nitrate anion, ion chromatography stands out as a robust and selective method. The selection of the most appropriate technique should be based on the specific analytical requirements of the user, including sensitivity, sample throughput, and available resources. Adherence to the detailed protocols and proper method validation will ensure the generation of accurate and defensible data.

References

- Analytik Jena. (n.d.). Analysis of Rare Earth Elements by ICP-OES and ICP-MS – Potentials and Limitations. Analytik Jena.
- U.S. Department of Energy. (2016, April 14). Analysis of Rare Earth Elements in Geologic Samples using Inductively Coupled Plasma Mass Spectrometry. U.S. Department of Energy.
- Technology Networks. (n.d.). Analysis of Rare Earth Elements by ICP-OES and ICP-MS – Potentials and Limitations. Technology Networks.
- Lichte, F. E., Meier, A. L., & Crock, J. G. (2002). Determination of the rare-earth elements in geological materials by inductively coupled plasma mass spectrometry. USGS Publications Warehouse.
- Zheng, L., et al. (2022). Determination of Rare Earth Elements by Inductively Coupled Plasma–Tandem Quadrupole Mass Spectrometry With Nitrous Oxide as the Reaction Gas. *Frontiers in Chemistry*, 10, 889311.

- Prohaska, T., et al. (n.d.). Operating conditions of the ICP-OES instrument for Nd measurements. ResearchGate.
- University of North Carolina at Chapel Hill. (n.d.). Neodymium Isotope Geochemistry. University of North Carolina at Chapel Hill.
- Sari, P. P., et al. (2024). Validation of The Gravimetry Method for Determining Rare Earth Elements Oxides. AIP Conference Proceedings.
- Sari, P. P., et al. (2024). Validation of The Gravimetry Method for Determining Rare Earth Elements Oxides. Eksplorium.
- PACE Technologies. (n.d.). Metallography for Neodymium rare earth magnets. PACE Technologies.
- Spectroscopy Online. (n.d.). High-Resolution ICP-OES for the Determination of Trace Elements in a Rare Earth Element Matrix and in NdFeB Magnetic Materials. Spectroscopy Online.
- Rodden, C. J. (n.d.). Spectrophotometric determination of praseodymium, neodymium, and samarium. NIST Technical Series Publications.
- Jones, A. M., et al. (n.d.). Measuring Nd(III) Solution Concentration in the Presence of Interfering Er(III) and Cu(II) Ions: A Partial Least Squares Analysis of Ultraviolet–Visible Spectra. OSTI.GOV.
- Verma, S. P. (n.d.). Statistical Evaluation of Analytical Methods for the Determination of Rare-Earth Elements in Geological Materials and Implications for Detection Limits. ResearchGate.
- Isobar Science. (2022, March 8). Sample Preparation for Sr-Nd-Hf-Pb Isotope Analysis. YouTube.
- Verma, S. P. (n.d.). Statistical Evaluation of Analytical Methods for the Determination of Rare-Earth Elements in Geological Materials and Implications for Detection Limits. Scilit.
- Verma, S. P. (n.d.). STATISTICAL EVALUATION OF ANALYTICAL METHODS FOR THE DETERMINATION OF RARE-EARTH ELEMENTS IN GEOLOGICAL MATERIALS AND IMPLICATIONS FOR DETECTION LIMITS. DSpace Home.
- Unknown. (n.d.). Complexometric Titrations.
- Gold Refining & Metal Extraction Forum. (2017, July 8). [Help]Titration complexon rare earth - EDTA. Gold Refining & Metal Extraction Forum.
- Bendola Publishing. (n.d.). Synthesis and Characterization of Nd O Nanoparticles Using Urea As Precipitation Agent. Bendola Publishing.
- ResearchGate. (n.d.). spectra of standard solutions of rare earth elements by using a UV-Visible spectrophotometer. ResearchGate.
- AZoM. (2023, December 7). Analyzing Rare Earth Elements by ICP-OES. AZoM.
- da Silva, C. G., et al. (2015). Preparation of High Purity Neodymium Oxide from Brazilian Monazite by Ion Exchange. Materials Research, 18(Suppl. 2), 2-7.

- Bakker, E. (2016). Complexometric titrations: new reagents and concepts to overcome old limitations. *Analyst*, 141(14), 4252-4261.
- ResearchGate. (n.d.). Development and Validation Method for the Determination of Rare Earth Impurities in High Purity Neodymium Oxide by ICP-MS. ResearchGate.
- Unknown. (n.d.). CHE-HC-4014: INORGANIC CHEMISTRY-III Topic: Theory of complexometric titrations.
- Agilent. (n.d.). What is UV-Visible/UV-Vis Spectroscopy? Principles Overview. Agilent.
- YouTube. (2024, September 29). COMPLEXOMETRIC or EDTA TITRATION PRINCIPLE METAL IONS HARDNESS Estimation CHELATOMETRY Stability. YouTube.
- Li, Y., et al. (2024). Quantitative study on hepatic genotoxicity of neodymium and its molecular mechanisms based on Benchmark Dose method. *Frontiers in Pharmacology*, 15, 1339673.
- Higgins, C. E., & Baldwin, W. H. (n.d.). Liquid-liquid extraction of neodymium and samarium nitrates. OSTI.GOV.
- Ali, R., et al. (2024). Analytical Techniques for Detecting Rare Earth Elements in Geological Ores: Laser-Induced Breakdown Spectroscopy (LIBS), MFA-LIBS, Thermal LIBS, Laser Ablation Time-of-Flight Mass Spectrometry, Energy-Dispersive X-ray Spectroscopy, Energy-Dispersive X-ray Fluorescence Spectrometer, and Inductively Coupled Plasma Optical Emission Spectroscopy. *Molecules*, 29(20), 4683.
- Ito, K., et al. (2005). Ion chromatography for determination of nitrite and nitrate in seawater using monolithic ODS columns. *Journal of Chromatography A*, 1083(1-2), 63-67.
- Technology Networks. (2023, December 18). UV-Vis Spectroscopy: Principle, Strengths and Limitations and Applications. Technology Networks.
- Shimadzu. (n.d.). Determination of Nitrite, Bromide and Nitrate in Seawater Using Ion Chromatography. Shimadzu.
- Melnikov, P., et al. (2019). Thermoanalytical behavior of neodymium nitrate hexahydrate $\text{Nd}(\text{NO}_3)_3 \cdot 6\text{H}_2\text{O}$. *Journal of Thermal Analysis and Calorimetry*, 138, 3493-3497.
- Thermo Fisher Scientific. (n.d.). Simultaneous Determination of Nitrate and Nitrite in Spinach and Meat by Ion Chromatography. Thermo Fisher Scientific.
- MDPI. (n.d.). Emerging Analytical Techniques for Rare Earth Element Study: Basic Principles and Cutting-Edge Developments. MDPI.
- Wu, L., et al. (n.d.). Ion Chromatographic Determination of Nitrite and Nitrate in Tobacco Leaf.
- Melnikov, P., et al. (2019). Thermoanalytical behavior of neodymium nitrate hexahydrate $\text{Nd}(\text{NO}_3)_3 \cdot 6\text{H}_2\text{O}$. OUCI.

Need Custom Synthesis?

BenchChem offers custom synthesis for rare earth carbides and specific isotopic labeling.

Email: info@benchchem.com or [Request Quote Online](#).

Sources

- [1. Metallography for Neodymium rare earth magnets \[metallographic.com\]](#)
- [2. bendola.com \[bendola.com\]](#)
- [3. semanticscholar.org \[semanticscholar.org\]](#)
- [4. ouci.dntb.gov.ua \[ouci.dntb.gov.ua\]](#)
- [5. selectscience.net \[selectscience.net\]](#)
- [6. analytik-jena.ru \[analytik-jena.ru\]](#)
- [7. spectroscopyonline.com \[spectroscopyonline.com\]](#)
- [8. azom.com \[azom.com\]](#)
- [9. researchgate.net \[researchgate.net\]](#)
- [10. Determination of Rare Earth Elements by Inductively Coupled Plasma–Tandem Quadrupole Mass Spectrometry With Nitrous Oxide as the Reaction Gas - PMC \[pmc.ncbi.nlm.nih.gov\]](#)
- [11. netl.doe.gov \[netl.doe.gov\]](#)
- [12. Determination of the rare-earth elements in geological materials by inductively coupled plasma mass spectrometry \[pubs.usgs.gov\]](#)
- [13. nvlpubs.nist.gov \[nvlpubs.nist.gov\]](#)
- [14. osti.gov \[osti.gov\]](#)
- [15. agilent.com \[agilent.com\]](#)
- [16. acikders.ankara.edu.tr \[acikders.ankara.edu.tr\]](#)
- [17. nowgonggirlscollege.co.in \[nowgonggirlscollege.co.in\]](#)
- [18. goldrefiningforum.com \[goldrefiningforum.com\]](#)
- [19. Complexometric titrations: new reagents and concepts to overcome old limitations - PubMed \[pubmed.ncbi.nlm.nih.gov\]](#)

- [20. documents.thermofisher.com](https://documents.thermofisher.com) [documents.thermofisher.com]
- [21. Ion chromatography for determination of nitrite and nitrate in seawater using monolithic ODS columns - PubMed](https://pubmed.ncbi.nlm.nih.gov) [pubmed.ncbi.nlm.nih.gov]
- [22. chromatographytoday.com](https://chromatographytoday.com) [chromatographytoday.com]
- [23. asianpubs.org](https://asianpubs.org) [asianpubs.org]
- [24. ejournal.brin.go.id](https://ejournal.brin.go.id) [ejournal.brin.go.id]
- To cite this document: BenchChem. [Application and Protocol Guide for the Quantification of Neodymium Trinitrate]. BenchChem, [2026]. [Online PDF]. Available at: [<https://www.benchchem.com/product/b157462/docs#application-and-protocol-guide-for-the-quantification-of-neodymium-trinitrate>]

Disclaimer & Data Validity:

The information provided in this document is for Research Use Only (RUO) and is strictly not intended for diagnostic or therapeutic procedures. While BenchChem strives to provide accurate protocols, we make no warranties, express or implied, regarding the fitness of this product for every specific experimental setup.

Technical Support: The protocols provided are for reference purposes. Unsure if this reagent suits your experiment?

Need Industrial/Bulk Grade? [Request Custom Synthesis Quote](#)

BenchChem

Our mission is to be the trusted global source of essential and advanced chemicals, empowering scientists and researchers to drive progress in science and industry.

Contact

Address: 3281 E Guasti Rd
Ontario, CA 91761, United States
Phone: (601) 213-4426
Email: info@benchchem.com

Contact our Ph.D. Support Team for a compatibility check