

Technical Support Center: Validating QO 58 Activity

Author: BenchChem Technical Support Team. **Date:** December 2025

Compound of Interest

Compound Name: QO 58

Cat. No.: B15623911

[Get Quote](#)

This technical support center provides troubleshooting guidance and frequently asked questions (FAQs) for researchers, scientists, and drug development professionals working with the Kv7 channel opener, **QO 58**.

Frequently Asked Questions (FAQs)

Q1: What is **QO 58** and what is its primary mechanism of action?

A1: **QO 58** is a potent, small molecule modulator that functions as an opener for the Kv7 (KCNQ) family of voltage-gated potassium channels.[1][2] Its primary mechanism of action involves directly interacting with the voltage-sensing domain (VSD) of the Kv7.2 channel subunit.[3] This interaction stabilizes the open state of the channel, leading to a hyperpolarizing shift in the voltage-dependence of activation and a slowing of the deactivation kinetics.[2][3] By enhancing the M-type potassium current (IKM), **QO 58** effectively reduces neuronal excitability.[2][3]

Q2: In which cell lines can I validate **QO 58** activity?

A2: **QO 58** activity is commonly validated in mammalian cell lines that do not endogenously express Kv7 channels, making them suitable for heterologous expression of the desired channel subtypes. The most frequently used cell lines are Chinese Hamster Ovary (CHO) cells and Human Embryonic Kidney (HEK293) cells.[3][4] Additionally, studies have been conducted in pituitary tumor (GH3) cells, which endogenously express some relevant ion channels.[5][6]

Q3: What is the selectivity profile of **QO 58** across different Kv7 channel subtypes?

A3: **QO 58** exhibits selectivity among the Kv7 channel subtypes. It is most potent on Kv7.2, Kv7.4, and heteromeric Kv7.2/Kv7.3 channels.[1][7][8] It shows moderate activity on Kv7.1 and Kv7.3/Kv7.5 channels and has minimal effect on homomeric Kv7.3 channels.[1][7][8]

Q4: Are there any known off-target effects of **QO 58**?

A4: Yes, researchers should be aware of potential off-target effects. One study has reported that **QO 58** can act as a positive allosteric modulator of nicotinic acetylcholine receptors (nAChRs), potentiating nicotine-induced currents independently of its action on Kv7 channels. [8][9] Another study in GH3 cells showed that **QO 58** can also increase the amplitude of Ca²⁺-activated K⁺ current (IK(Ca)) and enhance the activity of large-conductance Ca²⁺-activated K⁺ (BKCa) channels.[5][6]

Q5: What is the difference between **QO 58** and QO58-lysine?

A5: QO58-lysine is a salt form of **QO 58**, synthesized to improve its solubility and bioavailability for in vivo studies.[10] Electrophysiological studies have confirmed that QO58-lysine activates Kv7.2/Kv7.3 channels in the same manner as the original **QO 58** compound.[10]

Troubleshooting Guide

Issue 1: No observable effect of **QO 58** on whole-cell currents.

- Possible Cause 1: Poor Compound Solubility.
 - Solution: **QO 58** has low aqueous solubility. Ensure it is completely dissolved in a suitable solvent like DMSO at a high stock concentration before diluting to the final working concentration in the external recording solution.[11] Sonicate or vortex the stock solution if necessary. A lysine salt version, QO58-lysine, has improved solubility.[10]
- Possible Cause 2: Incorrect Cell Line or Channel Expression.
 - Solution: Confirm that the cell line used (e.g., HEK293, CHO) has been successfully transfected with the Kv7 channel subtype(s) of interest.[4] Verify transfection efficiency

using a reporter gene (e.g., GFP) or by performing control experiments with a known Kv7 channel activator, such as retigabine.

- Possible Cause 3: Inappropriate Voltage Protocol.
 - Solution: The effect of **QO 58** is voltage-dependent. Ensure your voltage-clamp protocol is designed to open Kv7 channels. A typical protocol involves holding the cell at a negative potential (e.g., -80 mV) and then applying depolarizing steps to potentials where the channels activate (e.g., -40 mV).[7]

Issue 2: High variability in **QO 58** potency (EC50) between experiments.

- Possible Cause 1: Inconsistent Drug Application.
 - Solution: Use a rapid and reliable perfusion system to ensure consistent and complete exchange of the external solution containing **QO 58**.^[4] Incomplete washout between applications can also affect subsequent measurements.
- Possible Cause 2: Fluctuation in Intracellular Environment.
 - Solution: The perforated patch-clamp technique is often recommended to preserve the intracellular signaling environment, which can influence channel activity.^{[3][7]} If using the whole-cell configuration, be mindful of potential rundown of the current over time.
- Possible Cause 3: Differences in Cell Passage Number or Health.
 - Solution: Use cells from a consistent and low passage number range. Ensure cells are healthy and not overly confluent at the time of recording, as this can impact channel expression and overall cellular physiology.

Issue 3: Observed effects do not match the expected Kv7 channel activity profile.

- Possible Cause 1: Off-Target Effects.
 - Solution: Be aware of **QO 58**'s known off-target activities on nAChRs and BKCa channels. ^{[5][6][8][9]} To isolate the effect on Kv7 channels, consider using specific blockers. For instance, the Kv7 channel blocker XE991 can be used to confirm that the observed current

is mediated by Kv7 channels.[10] To rule out effects on BKCa channels, experiments can be performed in Ca²⁺-free external solution.

- Possible Cause 2: Presence of Endogenous Channels.
 - Solution: While HEK293 and CHO cells have low endogenous channel expression, it's crucial to characterize the baseline currents in untransfected cells to ensure there is no confounding endogenous activity.

Quantitative Data Summary

Table 1: Potency (EC₅₀) of **QO 58** on Various Kv7 Channel Subtypes

Channel Subtype	Cell Line	EC ₅₀ (μM)	Reference
Kv7.1	-	7.0	
Kv7.2	-	1.0	
Kv7.2/Kv7.3	CHO	2.3 ± 0.8	[7]
Kv7.2/Kv7.3 (QO58-lysine)	HEK293	1.2 ± 0.2	[10]
Kv7.3/Kv7.5	-	5.2	
Kv7.4	-	0.6	

Table 2: Effects of **QO 58** on M-type (IK(M)) and Ca²⁺-activated (IK(Ca)) K⁺ Currents in GH3 Cells

Current Type	EC ₅₀ (μM)	Effect	Reference
IK(M)	3.1	Increased current amplitude, leftward shift in activation curve	[5][6]
IK(Ca)	4.2	Increased current amplitude	[5][6]

Experimental Protocols

Protocol 1: Whole-Cell Patch-Clamp Electrophysiology for **QO 58** Activity

This protocol is a standard method for measuring the activity of **QO 58** on heterologously expressed Kv7 channels.[4]

- Cell Culture and Transfection:
 - Culture mammalian cells (e.g., HEK293 or CHO) in standard conditions.
 - Transiently or stably transfect the cells with plasmids containing the cDNA for the specific human Kv7 channel subtype(s) of interest.
- Electrophysiological Recording:
 - Use a glass micropipette to form a high-resistance seal with the membrane of a single transfected cell.
 - Rupture the membrane patch under the pipette tip to establish the "whole-cell" configuration, or use the perforated patch technique with an agent like amphotericin B in the pipette solution.[3][9]
 - Internal Solution (Example): 70 mM CsCl, 80 mM cesium methanesulfonate, 10 mM HEPES, adjusted to pH 7.3.[9]
 - External Solution (Example): 150 mM NaCl, 2.5 mM KCl, 1 mM MgCl₂, 2 mM CaCl₂, 10 mM HEPES, 10 mM glucose, adjusted to pH 7.4.[9]
- Voltage Clamp Protocol:
 - Clamp the cell membrane potential at a holding potential of -80 mV, where Kv7 channels are predominantly closed.
 - Apply a series of depolarizing voltage steps (e.g., in 10 mV increments from -130 to +30 mV) to activate the channels and elicit outward potassium currents.[7]
- Compound Application:

- Prepare a stock solution of **QO 58** in DMSO (e.g., 10-20 mM).[9][11]
- Apply **QO 58** to the cell at various concentrations via a perfusion system.
- Record the effect of the compound on the Kv7 currents. An increase in current amplitude and/or a leftward shift in the voltage-dependence of activation indicates channel opening activity.
- Data Analysis:
 - Analyze the recorded currents to determine the concentration-response relationship for **QO 58**.
 - Calculate the EC50 value by fitting the data to a logistic equation.

Visualizations

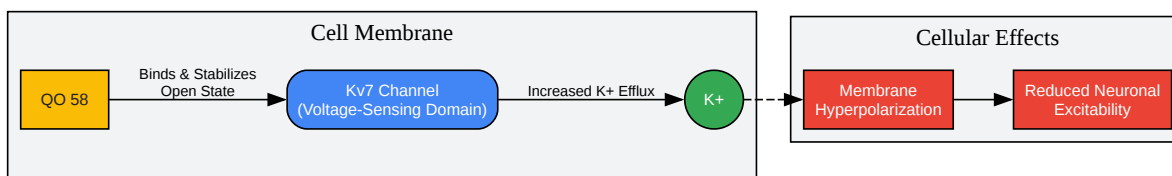

[Click to download full resolution via product page](#)

Caption: Signaling pathway of **QO 58** action on Kv7 channels.

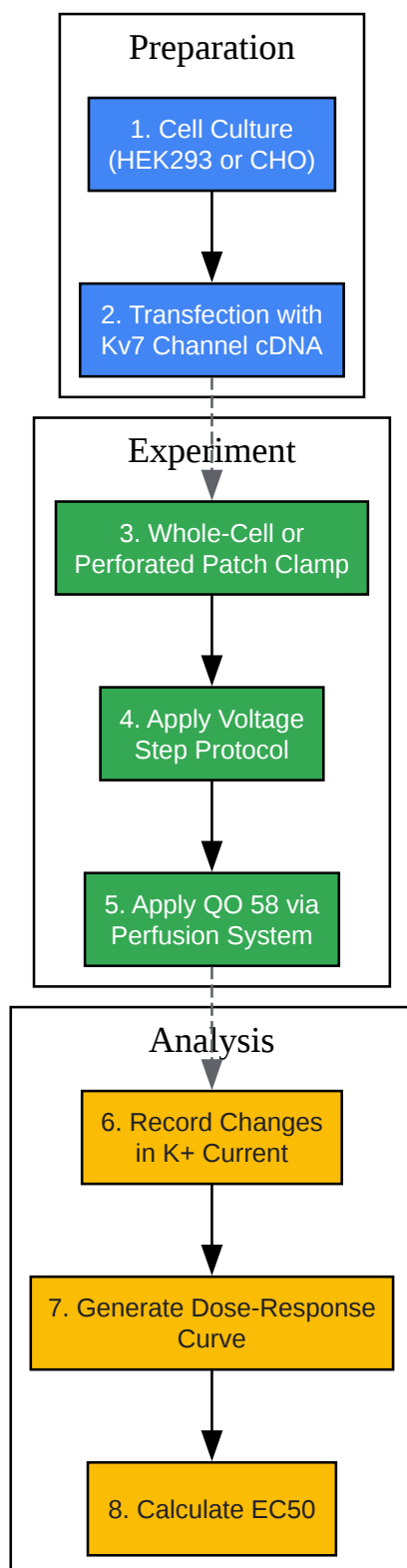

[Click to download full resolution via product page](#)

Caption: Experimental workflow for validating **QO 58** activity.

Need Custom Synthesis?

BenchChem offers custom synthesis for rare earth carbides and specific isotopic labeling.

Email: info@benchchem.com or [Request Quote Online](#).

References

- 1. Modulation of K(v)7 potassium channels by a novel opener pyrazolo[1,5-a]pyrimidin-7(4H)-one compound QO-58 - PubMed [pubmed.ncbi.nlm.nih.gov]
- 2. benchchem.com [benchchem.com]
- 3. benchchem.com [benchchem.com]
- 4. benchchem.com [benchchem.com]
- 5. mdpi.com [mdpi.com]
- 6. Evidence for Dual Activation of IK(M) and IK(Ca) Caused by QO-58 (5-(2,6-Dichloro-5-fluoropyridin-3-yl)-3-phenyl-2-(trifluoromethyl)-1H-pyrazolo[1,5-a]pyrimidin-7-one) - PMC [pmc.ncbi.nlm.nih.gov]
- 7. Modulation of Kv7 potassium channels by a novel opener pyrazolo[1,5-a]pyrimidin-7(4H)-one compound QO-58 - PMC [pmc.ncbi.nlm.nih.gov]
- 8. benchchem.com [benchchem.com]
- 9. Potentiation of Nicotine-Induced Currents by QO58, a Kv7 Channel Opener, in Intracardiac Ganglion Neurons of Rats [jstage.jst.go.jp]
- 10. Activation of neuronal Kv7/KCNQ/M-channels by the opener QO58-lysine and its anti-nociceptive effects on inflammatory pain in rodents - PMC [pmc.ncbi.nlm.nih.gov]
- 11. medchemexpress.com [medchemexpress.com]
- To cite this document: BenchChem. [Technical Support Center: Validating QO 58 Activity]. BenchChem, [2025]. [Online PDF]. Available at: [https://www.benchchem.com/product/b15623911#validating-qo-58-activity-in-different-cell-lines]

Disclaimer & Data Validity:

The information provided in this document is for Research Use Only (RUO) and is strictly not intended for diagnostic or therapeutic procedures. While BenchChem strives to provide

accurate protocols, we make no warranties, express or implied, regarding the fitness of this product for every specific experimental setup.

Technical Support: The protocols provided are for reference purposes. Unsure if this reagent suits your experiment? [[Contact our Ph.D. Support Team for a compatibility check](#)]

Need Industrial/Bulk Grade? [Request Custom Synthesis Quote](#)

BenchChem

Our mission is to be the trusted global source of essential and advanced chemicals, empowering scientists and researchers to drive progress in science and industry.

Contact

Address: 3281 E Guasti Rd

Ontario, CA 91761, United States

Phone: (601) 213-4426

Email: info@benchchem.com