

# Technical Support Center: Control Experiments for SAHM1 Functional Studies

**Author:** BenchChem Technical Support Team. **Date:** April 2026

## Compound of Interest

Compound Name: SAHM1  
Cat. No.: B15623454

[Get Quote](#)

This guide provides troubleshooting advice and frequently asked questions (FAQs) for researchers using **SAHM1**, a stapled peptide inhibitor of the Notch signaling pathway.<sup>[1]</sup> Proper control experiments are critical for interpreting data generated with this novel therapeutic agent.

## Frequently Asked Questions (FAQs)

Q1: What is **SAHM1** and what is its mechanism of action?

**SAHM1** is a synthetic, cell-permeable, hydrocarbon-stapled alpha-helical peptide. It is designed to mimic the Mastermind-like 1 (MAML1) protein and directly target the NOTCH transactivation complex.<sup>[2][3]</sup> By binding to the NOTCH intracellular domain (NICD) and CSL (CBF1/Su(H)/Lag-1) complex, **SAHM1** prevents the recruitment of MAML1, thereby inhibiting the transcription of NOTCH target genes such as HES1, MYC, and DTX1.<sup>[2][4]</sup>

Q2: What are the essential negative controls for an experiment using **SAHM1**?

It is crucial to include multiple negative controls to ensure the observed effects are specific to **SAHM1**'s inhibition of the NOTCH pathway.

- **Vehicle Control:** This is the solvent used to dissolve the **SAHM1** peptide (e.g., sterile water or PBS).[5] This control accounts for any effects of the vehicle on the experimental system.
- **Inactive Control Peptide:** An ideal negative control is a scrambled or structurally related but inactive version of the **SAHM1** peptide.[1] This helps to control for off-target effects related to the peptide's chemical nature.[2] Some studies have used **SAHM1-D1**, an inactive diastereomer of **SAHM1**. [2]
- **Cell Lines Insensitive to NOTCH Inhibition:** Using cell lines that are not dependent on NOTCH signaling for their growth or the phenotype being studied can help confirm the specificity of **SAHM1**. [2] For example, K562 (erythroleukemia) or JURKAT/MOLT-4 (T-ALL lines with PTEN loss) have shown insensitivity to **SAHM1**. [2]

Q3: What positive controls should I use to confirm **SAHM1** is working as expected?

- **Gamma-Secretase Inhibitors (GSIs):** GSIs, such as DAPT, are well-characterized inhibitors of the NOTCH pathway that act upstream of **SAHM1** by preventing the cleavage and release of the NICD. [2][4][5] Comparing the effects of **SAHM1** to a GSI can help validate that the observed phenotype is due to NOTCH pathway inhibition. [2]
- **NOTCH-Dependent Cell Lines:** Use cell lines known to be sensitive to NOTCH inhibition, such as T-ALL cell lines with activating NOTCH1 mutations (e.g., KOPT-K1, HPB-ALL). [2][4] A reduction in proliferation or induction of apoptosis in these cells following **SAHM1** treatment would indicate the peptide is active. [2]
- **Monitoring Downstream Target Genes:** Measure the mRNA or protein levels of known NOTCH target genes (HES1, MYC, DTX1) via qRT-PCR or Western blotting. [4] A significant decrease in the expression of these genes upon **SAHM1** treatment serves as a direct measure of its on-target activity. [2][4]

Q4: I'm observing high variability or unexpected toxicity in my cell-based assays. What could be the cause?

Several factors related to the nature of synthetic peptides can contribute to these issues:

- **Peptide Solubility:** **SAHM1** is soluble in water up to 1 mg/ml. However, improper dissolution can lead to aggregation and inconsistent results. [6] It is recommended to freshly prepare

solutions and, if necessary, use sonication to aid dissolution.[6]

- Counter-ion Contamination: Trifluoroacetic acid (TFA) is often used in peptide synthesis and purification. Residual TFA can be toxic to cells, leading to erratic cell growth or death.[7][8] If you suspect TFA toxicity, consider using TFA-removed peptides.[8]
- Improper Storage: Peptides should be stored lyophilized at -20°C and protected from light.[7] Avoid repeated freeze-thaw cycles, which can lead to degradation.[7]
- Endotoxin Contamination: Endotoxins (lipopolysaccharides) from bacteria can cause unwanted immune responses in cell culture, especially in immunological assays.[7] Using peptides with guaranteed low endotoxin levels is recommended for such experiments.[7]

## Troubleshooting Guide

Problem	Potential Cause(s)	Recommended Solution(s)
No effect of SAHM1 on NOTCH target gene expression.	<ul style="list-style-type: none"> <li>- Inactive peptide due to improper storage or handling.</li> <li>- Incorrect dosage.</li> <li>- Cell line is not responsive to NOTCH inhibition.</li> </ul>	<ul style="list-style-type: none"> <li>- Use a fresh aliquot of SAHM1.</li> <li>- Perform a dose-response experiment to determine the optimal concentration (IC50 for reporter assays is ~6.5 <math>\mu</math>M).[4]</li> <li>- Confirm NOTCH pathway activity in your cell line using a positive control (e.g., a known NOTCH ligand).</li> </ul>
High background in reporter assays.	<ul style="list-style-type: none"> <li>- "Leaky" reporter construct.</li> <li>- Off-target effects of the peptide.</li> </ul>	<ul style="list-style-type: none"> <li>- Use a reporter construct with a minimal promoter.</li> <li>- Include an inactive control peptide to assess non-specific effects.[1]</li> </ul>
Inconsistent results between experiments.	<ul style="list-style-type: none"> <li>- Peptide aggregation or degradation.</li> <li>- Variability in cell passage number or density.</li> </ul>	<ul style="list-style-type: none"> <li>- Prepare fresh peptide solutions for each experiment.</li> <li>- Standardize cell culture conditions, including passage number and seeding density.</li> </ul>
SAHM1 shows toxicity in a NOTCH-independent cell line.	<ul style="list-style-type: none"> <li>- Off-target effects of the peptide.</li> <li>- Contaminants in the peptide preparation (e.g., TFA, endotoxins).[7]</li> </ul>	<ul style="list-style-type: none"> <li>- Test an inactive control peptide to see if it recapitulates the toxicity.[1]</li> <li>- Consider using a higher purity or TFA-removed peptide preparation.[7][8]</li> </ul>

## Experimental Protocols & Data

### Quantitative Data Summary

Parameter	Value	Cell Line/System	Reference
IC50 (Reporter Assay)	6.5 ± 1.6 μM	NOTCH1-dependent luciferase reporter	[4]
Binding Affinity (Kd)	0.12 ± 0.02 μM	to NICD:CSL complex in vitro	[3]
Effective Concentration (in vivo)	1-3 μg per treatment	Murine model of allergic asthma	[5]

## Detailed Methodologies

### 1. NOTCH1-Dependent Luciferase Reporter Assay

- Objective: To quantify the inhibitory effect of **SAHM1** on NOTCH1 transcriptional activity.
- Protocol:
  - Co-transfect cells (e.g., HEK293T) with a NOTCH1-responsive firefly luciferase reporter plasmid and a constitutively active Renilla luciferase plasmid (for normalization).
  - After 24 hours, treat the cells with a range of **SAHM1** concentrations (e.g., 0.5 μM to 50 μM), a vehicle control, and a positive control (e.g., 15 μM DAPT).[2]
  - Incubate for an additional 24-48 hours.
  - Lyse the cells and measure firefly and Renilla luciferase activity using a dual-luciferase assay system.
  - Normalize the firefly luciferase signal to the Renilla luciferase signal.
  - Plot the normalized data against the **SAHM1** concentration to determine the IC50 value.[4]

### 2. qRT-PCR for NOTCH Target Gene Expression

- Objective: To measure the effect of **SAHM1** on the mRNA levels of endogenous NOTCH target genes.

- Protocol:
  - Plate a NOTCH-dependent cell line (e.g., KOPT-K1) and allow the cells to adhere or recover.[4]
  - Treat the cells with **SAHM1** (e.g., 20  $\mu$ M), an inactive control peptide, and a vehicle control for 24 hours.[4]
  - Isolate total RNA from the cells using a standard RNA extraction kit.
  - Synthesize cDNA using a reverse transcription kit.
  - Perform quantitative real-time PCR (qRT-PCR) using primers specific for NOTCH target genes (HES1, MYC, DTX1) and a housekeeping gene (e.g., GAPDH, ACTB) for normalization.
  - Calculate the relative fold change in gene expression using the  $\Delta\Delta$ Ct method.

## Visualizations

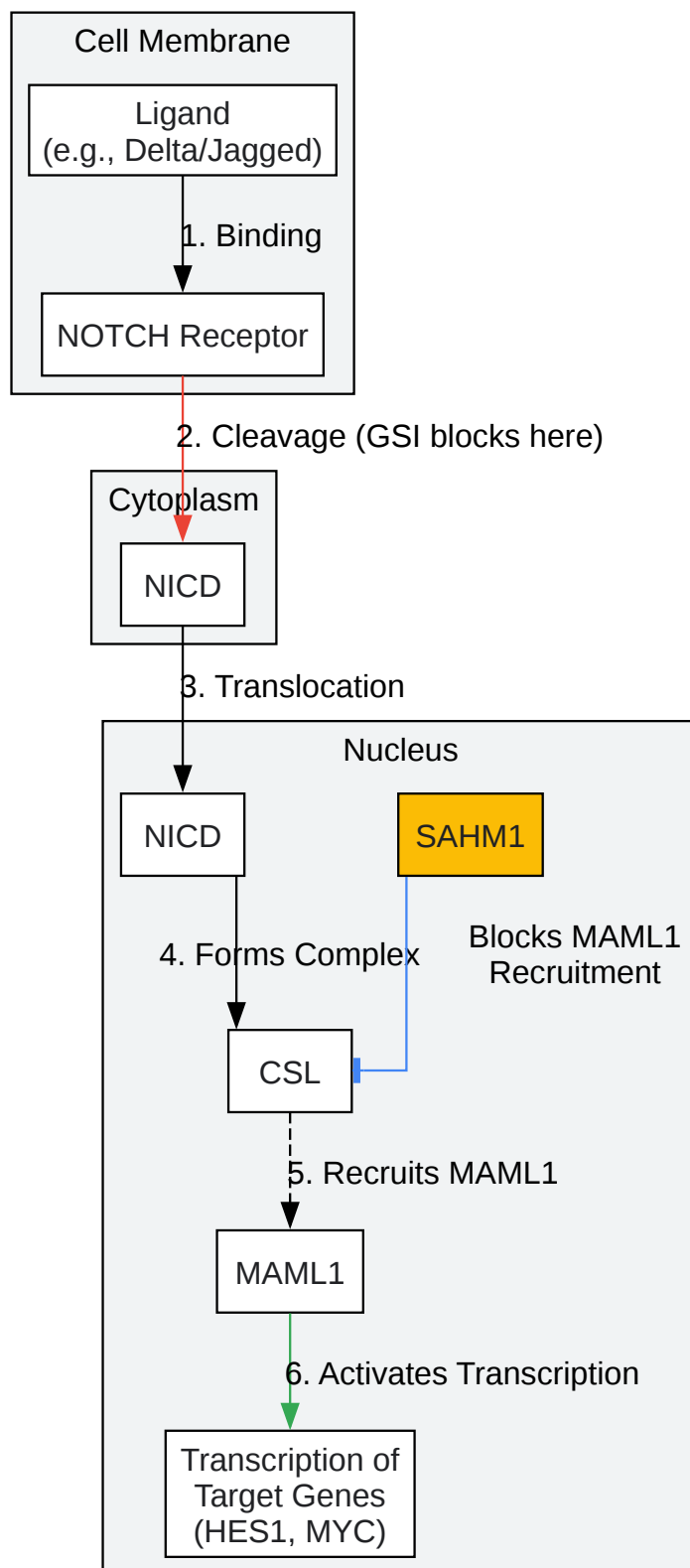

[Click to download full resolution via product page](#)

Caption: Mechanism of **SAHM1** in the NOTCH signaling pathway.

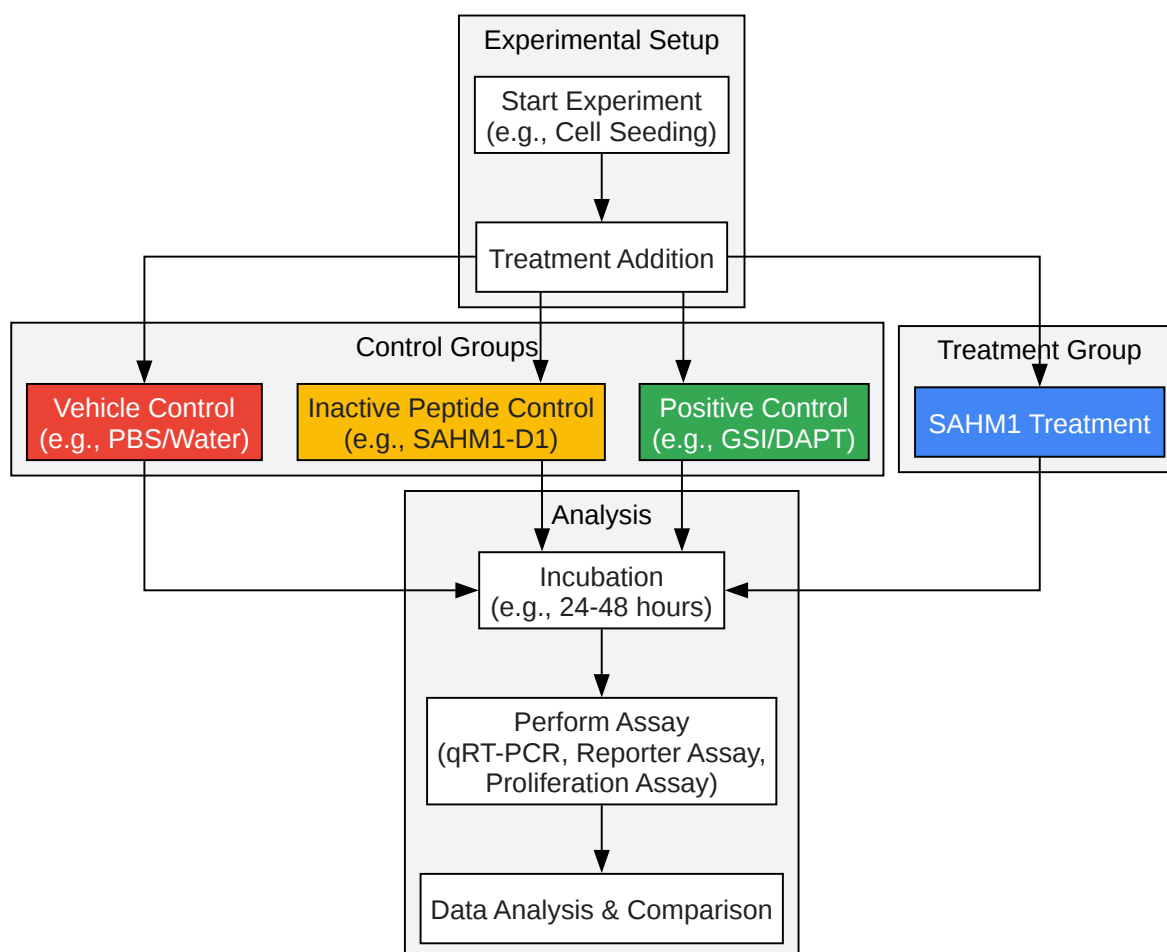

[Click to download full resolution via product page](#)

Caption: Workflow for **SAHM1** functional studies with controls.

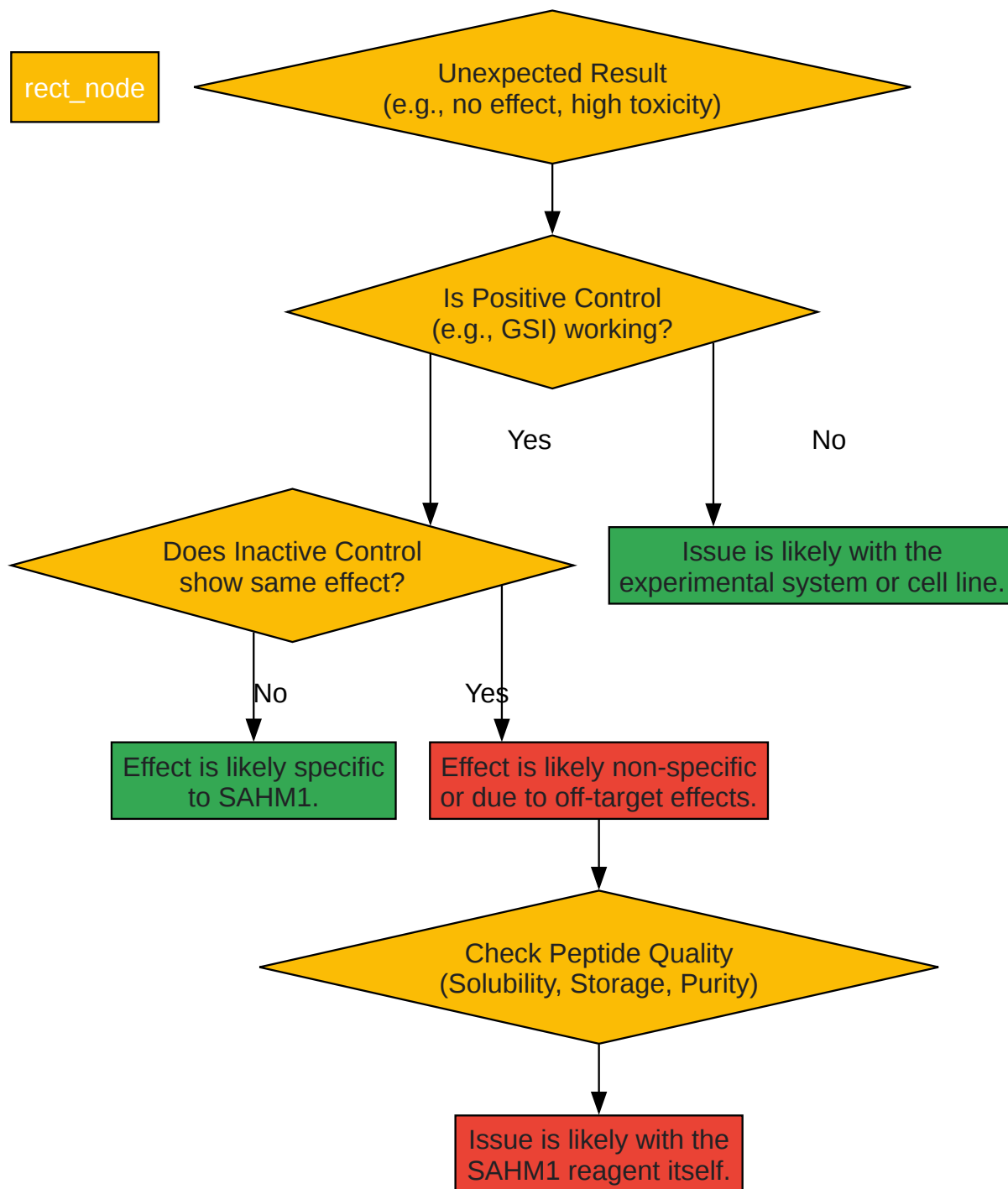

[Click to download full resolution via product page](#)

Caption: Troubleshooting decision tree for **SAHM1** experiments.

### Need Custom Synthesis?

BenchChem offers custom synthesis for rare earth carbides and specific isotopic labeling.

Email: [info@benchchem.com](mailto:info@benchchem.com) or [Request Quote Online](#).

## References

- 1. The Notch pathway inhibitor stapled  $\alpha$ -helical peptide derived from mastermind-like 1 (SAHM1) abrogates the hallmarks of allergic asthma - PubMed [[pubmed.ncbi.nlm.nih.gov](https://pubmed.ncbi.nlm.nih.gov)]
- 2. Direct inhibition of the NOTCH transcription factor complex - PMC [[pmc.ncbi.nlm.nih.gov](https://pmc.ncbi.nlm.nih.gov)]
- 3. Outsmarting a Mastermind - PMC [[pmc.ncbi.nlm.nih.gov](https://pmc.ncbi.nlm.nih.gov)]
- 4. [researchgate.net](https://researchgate.net) [[researchgate.net](https://researchgate.net)]
- 5. The Notch pathway inhibitor stapled  $\alpha$ -helical peptide derived from mastermind-like 1 (SAHM1) abrogates the hallmarks of allergic asthma - PMC [[pmc.ncbi.nlm.nih.gov](https://pmc.ncbi.nlm.nih.gov)]
- 6. [benchchem.com](https://benchchem.com) [[benchchem.com](https://benchchem.com)]
- 7. [genscript.com](https://genscript.com) [[genscript.com](https://genscript.com)]
- 8. [genscript.com](https://genscript.com) [[genscript.com](https://genscript.com)]
- To cite this document: BenchChem. [Technical Support Center: Control Experiments for SAHM1 Functional Studies]. BenchChem, [2026]. [Online PDF]. Available at: [<https://www.benchchem.com/product/b15623454/docs#technical-support-center-control-experiments-for-sahm1-functional-studies>]

---

### Disclaimer & Data Validity:

The information provided in this document is for Research Use Only (RUO) and is strictly not intended for diagnostic or therapeutic procedures. While BenchChem strives to provide accurate protocols, we make no warranties, express or implied, regarding the fitness of this product for every specific experimental setup.

**Technical Support:** The protocols provided are for reference purposes. Unsure if this reagent suits your experiment?

**Need Industrial/Bulk Grade?** [Request Custom Synthesis Quote](#)

# BenchChem

Our mission is to be the trusted global source of essential and advanced chemicals, empowering scientists and researchers to drive progress in science and industry.

## Contact

Address: 3281 E Guasti Rd

Ontario, CA 91761, United States

Phone: (601) 213-4426

Email: [info@benchchem.com](mailto:info@benchchem.com)

[Contact our Ph.D. Support Team for a compatibility check](#)