

High-Throughput Screening Using Thalidomide-5-propargyl: Application Notes and Protocols

Author: BenchChem Technical Support Team. **Date:** April 2026

Compound of Interest

Compound Name: *Thalidomide-5-propargyl*

CAS No.: 2226303-74-6

Cat. No.: B15623514

[Get Quote](#)

For Researchers, Scientists, and Drug Development Professionals

Introduction

Thalidomide and its analogues, known as immunomodulatory drugs (IMiDs), have seen a resurgence in therapeutic applications, most notably in the treatment of multiple myeloma.[1] Their mechanism of action involves binding to the Cereblon (CRBN) protein, a substrate receptor of the CUL4-RBX1-DDB1-CRBN (CRL4-CRBN) E3 ubiquitin ligase complex.[2] This binding event modulates the substrate specificity of the E3 ligase, leading to the ubiquitination and subsequent proteasomal degradation of specific "neosubstrates" such as Ikaros (IKZF1) and Aiolos (IKZF3).[3]

This application note focuses on **Thalidomide-5-propargyl**, a derivative of thalidomide functionalized with a propargyl group. This terminal alkyne moiety serves as a versatile chemical handle for "click chemistry," enabling its use as a powerful tool in high-throughput screening (HTS) campaigns for the discovery of novel CRBN ligands, interacting proteins, and modulators of the CRL4-CRBN pathway.

Mechanism of Action: Thalidomide-Induced Protein Degradation

Thalidomide and its derivatives act as "molecular glues" by inducing an interaction between CRBN and proteins that are not its natural substrates. This induced proximity leads to the polyubiquitination of the neosubstrate by the E3 ligase complex, marking it for degradation by the proteasome.

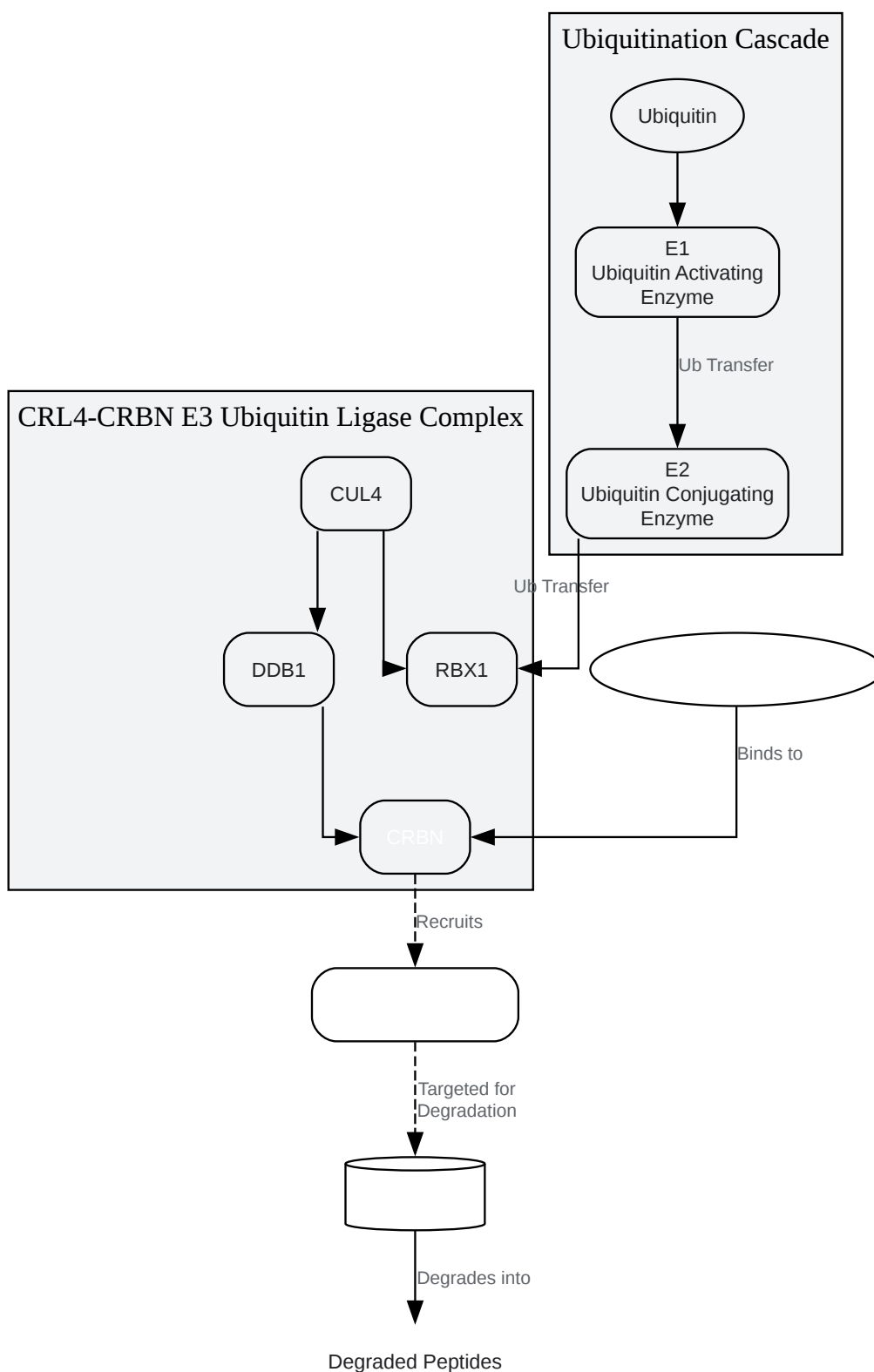

[Click to download full resolution via product page](#)

Caption: Mechanism of Thalidomide-induced protein degradation.

Quantitative Data: Binding Affinities of Thalidomide Derivatives to CRBN

While the precise binding affinity of **Thalidomide-5-propargyl** to CRBN is not extensively documented in publicly available literature, it is expected to be in a similar range to that of thalidomide. The following table summarizes the reported binding affinities for thalidomide and its well-characterized analogues, providing a benchmark for HTS assay development.

Compound	Binding Affinity (Kd or IC50) to CRBN	Assay Method	Reference
Thalidomide	~250 nM (Kd)	Fluorescence Polarization	[4]
Lenalidomide	~3 μ M (IC50)	Competitive Binding Assay	[5]
Pomalidomide	~3 μ M (IC50)	Competitive Binding Assay	[5]
(S)-Thalidomide	6- to 10-fold stronger than (R)-enantiomer	Competitive Elution Assay	[1]

High-Throughput Screening (HTS) Experimental Protocols

Thalidomide-5-propargyl can be employed in various HTS formats to either identify novel CRBN binders or to discover other proteins that interact with the thalidomide pharmacophore. Below are detailed protocols for three distinct HTS applications.

Competitive Fluorescence Polarization (FP) Assay for Novel CRBN Binders

This assay is designed to identify compounds that compete with a fluorescently labeled thalidomide derivative for binding to CRBN.

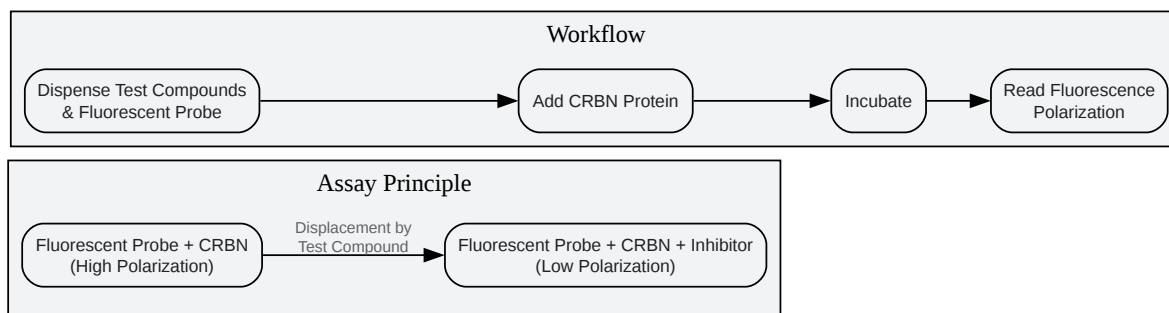

[Click to download full resolution via product page](#)

Caption: Workflow for a competitive Fluorescence Polarization HTS assay.

Protocol:

- Reagent Preparation:
 - Assay Buffer: Phosphate-buffered saline (PBS), pH 7.4, with 0.01% Tween-20.
 - CRBN Protein: Purified recombinant human CRBN (or the thalidomide-binding domain) diluted in Assay Buffer to a final concentration of 20 nM.
 - Fluorescent Tracer: A fluorescently labeled thalidomide derivative (e.g., Cy5-thalidomide) diluted in Assay Buffer to a final concentration of 5 nM.[6]
 - Test Compounds: Serially diluted in DMSO and then in Assay Buffer. **Thalidomide-5-propargyl** can be used as a positive control.
- Assay Procedure (384-well format):
 - Dispense 5 μ L of serially diluted test compounds or vehicle (DMSO) into the wells of a black, low-binding microplate.
 - Add 5 μ L of the fluorescent thalidomide tracer to all wells.

- Initiate the reaction by adding 10 μ L of the purified CRBN protein solution to all wells.
- Incubate the plate for 60 minutes at room temperature, protected from light.
- Measure the fluorescence polarization (in millipolarization units, mP) of each well using a suitable plate reader.
- Data Analysis:
 - Plot the mP values against the logarithm of the test compound concentration.
 - Fit the data using a sigmoidal dose-response curve to determine the IC₅₀ value for each compound. Hits are identified as compounds that cause a significant decrease in fluorescence polarization.

Cellular Thermal Shift Assay (CETSA) for Target Engagement

CETSA is a powerful method to confirm target engagement in a cellular context. Ligand binding stabilizes the target protein, resulting in a higher melting temperature. This protocol is adapted for a high-throughput format.[\[7\]](#)[\[8\]](#)

Protocol:

- Cell Culture and Treatment:
 - Seed cells (e.g., HEK293T) in 384-well PCR plates and culture overnight.
 - Treat the cells with a library of compounds at a single high concentration (e.g., 10 μ M) for 1 hour at 37°C. Include a DMSO vehicle control.
- Thermal Shift and Lysis:
 - Heat the plates in a thermal cycler for 3 minutes at a predetermined optimal temperature (e.g., 52°C), followed by a 3-minute cooling step at 25°C.
 - Lyse the cells by adding a lysis buffer containing a mild detergent and protease inhibitors.

- Detection of Soluble CRBN:
 - Centrifuge the plates at a low speed (e.g., 2000 x g) to pellet the aggregated, denatured proteins.
 - Transfer the supernatant containing the soluble protein fraction to a new 384-well plate.
 - Detect the amount of soluble CRBN using a suitable high-throughput method such as an AlphaLISA or a reverse-phase protein array (RPPA).[7]
- Data Analysis:
 - Normalize the signal for each well to the DMSO control.
 - Hits are identified as compounds that result in a significant increase in the amount of soluble CRBN compared to the vehicle control, indicating thermal stabilization.

In Situ Click Chemistry HTS for Novel Interacting Proteins

This novel HTS approach utilizes the propargyl group of **Thalidomide-5-propargyl** to identify proteins that bind to the thalidomide scaffold in a cellular lysate. The principle is that the target protein acts as a template, bringing the alkyne-functionalized probe and an azide-functionalized reporter into close proximity, thereby accelerating the "click" reaction.[9][10]

Protocol:

- Reagent Preparation:
 - Cell Lysate: Prepare a cell lysate from a relevant cell line (e.g., a multiple myeloma cell line) in a non-reducing buffer.
 - **Thalidomide-5-propargyl** Probe: A stock solution in DMSO.
 - Azide-Reporter: An azide-functionalized reporter molecule (e.g., azide-biotin or a fluorescent azide) in DMSO.

- Click Chemistry Reagents: Copper(II) sulfate (CuSO₄), a reducing agent (e.g., sodium ascorbate), and a copper-chelating ligand (e.g., THPTA).[11]
- Assay Procedure (384-well format):
 - Dispense the cell lysate into the wells of a 384-well plate.
 - Add **Thalidomide-5-propargyl** to a final concentration of 1-10 μM.
 - Add the azide-reporter to the wells.
 - Initiate the click reaction by adding the pre-mixed copper catalyst solution (CuSO₄, sodium ascorbate, and THPTA).
 - Incubate the plate at room temperature with gentle shaking for 1-2 hours.
- Detection and Hit Identification:
 - For Azide-Biotin Reporter: Transfer the reaction mixture to a streptavidin-coated plate. After washing, detect the captured protein-probe complexes using an antibody against a suspected interacting protein (e.g., CRBN as a positive control) or perform on-plate digestion followed by mass spectrometry for unbiased identification of "clicked" proteins.
 - For Fluorescent Azide Reporter: Analyze the plate using a fluorescence plate reader. An increase in fluorescence in specific wells (after removal of unbound fluorescent azide) indicates a protein-templated click reaction. Alternatively, the lysate can be run on an SDS-PAGE gel and imaged for fluorescently labeled proteins.
- Data Analysis:
 - For the biotin-based approach, hits are identified by a significant signal over background in the detection step. For the fluorescence-based approach, hits are identified by a significant increase in fluorescence intensity.

Concluding Remarks

Thalidomide-5-propargyl is a valuable chemical tool for the exploration of the CRL4-CRBN E3 ligase pathway. The HTS protocols detailed in this application note provide robust

methodologies for the identification of novel CRBN ligands and interacting partners. The competitive FP and CETSA protocols offer established methods for screening compound libraries for CRBN engagement, while the in situ click chemistry approach presents a novel strategy for target identification and validation. These high-throughput methods can significantly accelerate the discovery and development of new therapeutics targeting this important pathway.

Need Custom Synthesis?

BenchChem offers custom synthesis for rare earth carbides and specific isotopic labeling.

Email: info@benchchem.com or [Request Quote Online](#).

References

- [1. Molecular mechanisms of thalidomide and its derivatives - PMC \[pmc.ncbi.nlm.nih.gov\]](#)
- [2. Discovery of Highly Potent CRBN Ligands and Insight into Their Binding Mode through Molecular Docking and Molecular Dynamics Simulations - PubMed \[pubmed.ncbi.nlm.nih.gov\]](#)
- [3. Patterns of substrate affinity, competition, and degradation kinetics underlie biological activity of thalidomide analogs - PMC \[pmc.ncbi.nlm.nih.gov\]](#)
- [4. medchemexpress.com \[medchemexpress.com\]](#)
- [5. Cereblon is a direct protein target for immunomodulatory and antiproliferative activities of lenalidomide and pomalidomide - PMC \[pmc.ncbi.nlm.nih.gov\]](#)
- [6. bpsbioscience.com \[bpsbioscience.com\]](#)
- [7. pubs.acs.org \[pubs.acs.org\]](#)
- [8. High-Throughput Detection of Ligand-Protein Binding Using a SplitLuc Cellular Thermal Shift Assay | Springer Nature Experiments \[experiments.springernature.com\]](#)
- [9. benchchem.com \[benchchem.com\]](#)
- [10. In situ click chemistry: probing the binding landscapes of biological molecules - Chemical Society Reviews \(RSC Publishing\) \[pubs.rsc.org\]](#)
- [11. broadpharm.com \[broadpharm.com\]](#)
- To cite this document: BenchChem. [High-Throughput Screening Using Thalidomide-5-propargyl: Application Notes and Protocols]. BenchChem, [2026]. [Online PDF]. Available at:

[\[https://www.benchchem.com/product/b15623514/docs#high-throughput-screening-using-thalidomide-5-propargyl-application-notes-and-protocols\]](https://www.benchchem.com/product/b15623514/docs#high-throughput-screening-using-thalidomide-5-propargyl-application-notes-and-protocols)

Disclaimer & Data Validity:

The information provided in this document is for Research Use Only (RUO) and is strictly not intended for diagnostic or therapeutic procedures. While BenchChem strives to provide accurate protocols, we make no warranties, express or implied, regarding the fitness of this product for every specific experimental setup.

Technical Support: The protocols provided are for reference purposes. Unsure if this reagent suits your experiment?

Need Industrial/Bulk Grade? [Request Custom Synthesis Quote](#)

BenchChem

Our mission is to be the trusted global source of essential and advanced chemicals, empowering scientists and researchers to drive progress in science and industry.

Contact

Address: 3281 E Guasti Rd
Ontario, CA 91761, United States
Phone: (601) 213-4426
Email: info@benchchem.com

[Contact our Ph.D. Support Team for a compatibility check](#)