

GPR55 Signaling Pathways Under the Influence of ML-193: A Technical Guide

Author: BenchChem Technical Support Team. **Date:** April 2026

Compound of Interest

Compound Name: ML-193
Cat. No.: B15623253

[Get Quote](#)

For Researchers, Scientists, and Drug Development Professionals

Introduction

G protein-coupled receptor 55 (GPR55) has emerged as a novel and compelling therapeutic target implicated in a myriad of physiological and pathological processes, including pain perception, inflammation, bone density regulation, and cancer progression.[1][2][3] Initially explored as a potential cannabinoid receptor, GPR55 exhibits a distinct pharmacological profile and activates unique intracellular signaling cascades.[4] This technical guide provides an in-depth exploration of the signaling pathways governed by GPR55 and the inhibitory effects exerted by **ML-193**, a potent and selective antagonist.[5][6] The information presented herein is intended to equip researchers, scientists, and drug development professionals with the foundational knowledge required to investigate GPR55-mediated signaling and to design and execute experiments utilizing **ML-193** as a chemical probe.

GPR55: An Overview of its Signaling Mechanisms

GPR55 is a class A G protein-coupled receptor (GPCR) that, upon activation by its endogenous ligand, lysophosphatidylinositol (LPI), and other agonists, initiates a cascade of intracellular events.[1][7] Unlike the canonical cannabinoid receptors CB1 and CB2, which primarily couple

to Gi/o proteins, GPR55 signaling is predominantly mediated through Gαq, Gα12, and Gα13 subunits.[8][9][10][11]

Activation of these G proteins triggers several key downstream signaling pathways:

- **RhoA/ROCK Pathway:** GPR55 activation, particularly through Gα12/13, leads to the stimulation of the small GTPase RhoA and its downstream effector, Rho-associated kinase (ROCK).[3][4][8][12] This pathway is crucial for cytoskeleton rearrangement, including stress fiber formation, and plays a role in cell migration and proliferation.[7][12]
- **Phospholipase C (PLC) and Intracellular Calcium Mobilization:** Coupling to Gαq activates phospholipase C (PLC), which in turn hydrolyzes phosphatidylinositol 4,5-bisphosphate (PIP2) into inositol 1,4,5-trisphosphate (IP3) and diacylglycerol (DAG).[4][8] IP3 binds to its receptors on the endoplasmic reticulum, leading to the release of stored calcium (Ca²⁺) into the cytoplasm.[8][13] This increase in intracellular calcium is a critical signaling event that influences a wide range of cellular processes.[8][10]
- **Extracellular Signal-Regulated Kinase (ERK) Pathway:** GPR55 activation has been consistently shown to induce the phosphorylation and activation of the extracellular signal-regulated kinases 1 and 2 (ERK1/2).[2][14][6][15] The activation of the ERK pathway, a key component of the mitogen-activated protein kinase (MAPK) cascade, is often linked to cell proliferation, differentiation, and survival.[3][15] The upstream activators of ERK in the GPR55 pathway can include both the RhoA/ROCK and PLC/PKC axes.[12][16]
- **Transcription Factor Activation:** Downstream of these primary signaling events, GPR55 activation can modulate the activity of various transcription factors, including the nuclear factor of activated T-cells (NFAT), nuclear factor-kappa B (NF-κB), and cAMP response element-binding protein (CREB).[7][15][17] This highlights the receptor's role in regulating gene expression and eliciting long-term cellular changes.

ML-193: A Selective Antagonist of GPR55

ML-193 is a potent and selective small-molecule antagonist of GPR55.[14][5][6] It has been instrumental in elucidating the physiological and pathological roles of GPR55. **ML-193** exhibits high selectivity for GPR55 over other related receptors such as GPR35, CB1, and CB2, making it a valuable tool for in vitro and in vivo studies.[14][5][18]

Quantitative Effects of ML-193 on GPR55 Signaling

The inhibitory potency of **ML-193** on various GPR55-mediated signaling events has been quantified in several studies. The following tables summarize the key inhibitory concentration (IC50) values.

Assay	Agonist	Cell Line	IC50 of ML-193	Reference
β -arrestin Trafficking	L- α -lysophosphatidylinositol (LPI) (10 μ M)	U2OS	0.22 μ M (220 nM)	[1][14]
β -arrestin Trafficking	ML186 (1 μ M)	U2OS	0.12 μ M (120 nM)	[2][14]
ERK1/2 Phosphorylation	L- α -lysophosphatidylinositol (LPI)	U2OS	0.2 μ M (200 nM)	[2][14]
GPR55-dependent ERK Phosphorylation	-	-	65 nM	[6]
GPR55 Antagonism	-	-	221 nM	[14][5][6]

Experimental Protocols

Detailed methodologies are crucial for the reproducible investigation of GPR55 signaling and its modulation by **ML-193**. Below are representative protocols for key experiments.

Intracellular Calcium Mobilization Assay

This assay measures the ability of GPR55 agonists to induce the release of intracellular calcium and the inhibitory effect of **ML-193**.

1. Cell Culture and Preparation:

- HEK293 cells transiently or stably expressing human GPR55 are commonly used.[8]

- Cells are plated in black, clear-bottom 96-well plates and allowed to adhere overnight.

2. Dye Loading:

- The cell culture medium is removed, and cells are incubated with a calcium-sensitive fluorescent dye (e.g., Fura-2 AM or Fluo-4 AM) in a buffered salt solution (e.g., Hanks' Balanced Salt Solution with 20 mM HEPES) for 30-60 minutes at 37°C.

3. Compound Treatment:

- For antagonist studies, cells are pre-incubated with varying concentrations of **ML-193** for 15-30 minutes prior to agonist addition.[\[14\]](#)
- A GPR55 agonist, such as LPI (typically at a concentration that elicits a submaximal response, e.g., EC80), is then added.

4. Data Acquisition:

- Fluorescence intensity is measured over time using a fluorescence plate reader. An initial baseline reading is taken before the addition of the agonist.
- The change in fluorescence upon agonist addition reflects the increase in intracellular calcium concentration.

5. Data Analysis:

- The peak fluorescence response is calculated for each well.
- For **ML-193** inhibition studies, the data is normalized to the response of the agonist alone, and IC50 curves are generated.

ERK1/2 Phosphorylation Assay (Western Blotting)

This method is used to determine the effect of **ML-193** on GPR55-mediated activation of the ERK1/2 signaling pathway.

1. Cell Culture and Treatment:

- U2OS or HEK293 cells expressing GPR55 are seeded in multi-well plates.[\[2\]](#)[\[14\]](#)
- Cells are typically serum-starved for several hours to reduce basal ERK phosphorylation.
- Cells are pre-treated with different concentrations of **ML-193** for 30 minutes.[\[2\]](#)[\[14\]](#)

- Subsequently, cells are stimulated with a GPR55 agonist like LPI for a predetermined time (e.g., 5-30 minutes).

2. Cell Lysis:

- The medium is removed, and cells are washed with ice-cold phosphate-buffered saline (PBS).
- Cells are lysed on ice using a radioimmunoprecipitation assay (RIPA) buffer supplemented with protease and phosphatase inhibitors.

3. Protein Quantification:

- The total protein concentration in each lysate is determined using a standard protein assay (e.g., BCA assay).

4. Western Blotting:

- Equal amounts of protein from each sample are separated by SDS-PAGE and transferred to a nitrocellulose or PVDF membrane.
- The membrane is blocked with a blocking buffer (e.g., 5% non-fat milk or bovine serum albumin in Tris-buffered saline with Tween 20) for 1 hour at room temperature.
- The membrane is incubated overnight at 4°C with a primary antibody specific for phosphorylated ERK1/2 (p-ERK1/2).
- After washing, the membrane is incubated with a horseradish peroxidase (HRP)-conjugated secondary antibody for 1 hour at room temperature.
- The signal is detected using an enhanced chemiluminescence (ECL) substrate and imaged.
- To ensure equal protein loading, the membrane is subsequently stripped and re-probed with an antibody against total ERK1/2.

5. Data Analysis:

- The band intensities for p-ERK1/2 and total ERK1/2 are quantified using densitometry software.
- The ratio of p-ERK1/2 to total ERK1/2 is calculated for each sample.
- The inhibitory effect of **ML-193** is determined by comparing the p-ERK/total ERK ratio in treated cells to that in cells treated with the agonist alone.

Signaling Pathway Diagrams

The following diagrams, generated using Graphviz (DOT language), illustrate the key GPR55 signaling pathways and the point of inhibition by **ML-193**.

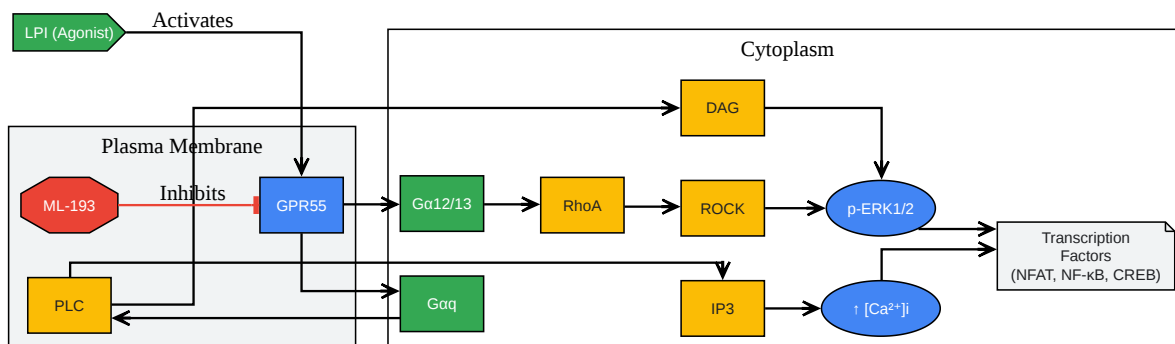

[Click to download full resolution via product page](#)

Caption: GPR55 signaling pathways and **ML-193** inhibition.

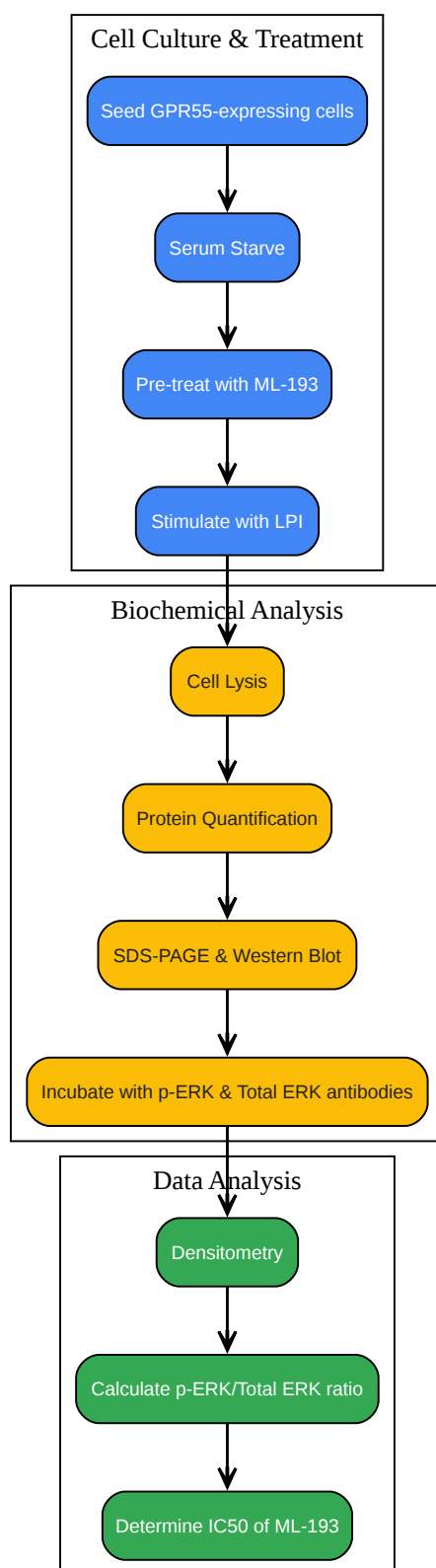

[Click to download full resolution via product page](#)

Caption: Workflow for ERK1/2 phosphorylation assay.

Conclusion

GPR55 represents a significant target for therapeutic intervention in a range of diseases. A thorough understanding of its complex signaling pathways is paramount for the development of novel modulators. **ML-193** serves as an indispensable pharmacological tool for dissecting the roles of GPR55 in cellular and organismal physiology. The data and protocols presented in this guide offer a comprehensive resource for researchers aiming to investigate this intriguing receptor and the consequences of its inhibition.

Need Custom Synthesis?

BenchChem offers custom synthesis for rare earth carbides and specific isotopic labeling.

Email: info@benchchem.com or [Request Quote Online](#).

References

- [1. apexbt.com \[apexbt.com\]](#)
- [2. IDENTIFICATION OF THE GPR55 ANTAGONIST BINDING SITE USING A NOVEL SET OF HIGH POTENCY GPR55 SELECTIVE LIGANDS - PMC \[pmc.ncbi.nlm.nih.gov\]](#)
- [3. Effects of a Novel GPR55 Antagonist on the Arachidonic Acid Cascade in LPS-Activated Primary Microglial Cells - PMC \[pmc.ncbi.nlm.nih.gov\]](#)
- [4. GPR55 - Wikipedia \[en.wikipedia.org\]](#)
- [5. rndsystems.com \[rndsystems.com\]](#)
- [6. caymanchem.com \[caymanchem.com\]](#)
- [7. GPR55: signaling pathways and functions - PMC \[pmc.ncbi.nlm.nih.gov\]](#)
- [8. GPR55 is a cannabinoid receptor that increases intracellular calcium and inhibits M current - PMC \[pmc.ncbi.nlm.nih.gov\]](#)
- [9. GPR55 ligands promote receptor coupling to multiple signalling pathways - PMC \[pmc.ncbi.nlm.nih.gov\]](#)
- [10. Advances in the Physiology of GPR55 in the Central Nervous System - PMC \[pmc.ncbi.nlm.nih.gov\]](#)
- [11. The Mechanisms of GPR55 Receptor Functional Selectivity during Apoptosis and Proliferation Regulation in Cancer Cells - PMC \[pmc.ncbi.nlm.nih.gov\]](#)

- [12. researchgate.net \[researchgate.net\]](#)
- [13. pnas.org \[pnas.org\]](#)
- [14. medchemexpress.com \[medchemexpress.com\]](#)
- [15. Activation of GPR55 increases neural stem cell proliferation and promotes early adult hippocampal neurogenesis - PMC \[pmc.ncbi.nlm.nih.gov\]](#)
- [16. Elucidation of GPR55-Associated Signaling behind THC and LPI Reducing Effects on Ki67-Immunoreactive Nuclei in Patient-Derived Glioblastoma Cells - PMC \[pmc.ncbi.nlm.nih.gov\]](#)
- [17. The GPR55 ligand L-alpha-lysophosphatidylinositol promotes RhoA-dependent Ca²⁺ signaling and NFAT activation - PubMed \[pubmed.ncbi.nlm.nih.gov\]](#)
- [18. Screening for Selective Ligands for GPR55 - Antagonists - Probe Reports from the NIH Molecular Libraries Program - NCBI Bookshelf \[ncbi.nlm.nih.gov\]](#)
- To cite this document: BenchChem. [GPR55 Signaling Pathways Under the Influence of ML-193: A Technical Guide]. BenchChem, [2026]. [Online PDF]. Available at: [\[https://www.benchchem.com/product/b15623253/docs#gpr55-signaling-pathways-under-the-influence-of-ml-193-a-technical-guide\]](https://www.benchchem.com/product/b15623253/docs#gpr55-signaling-pathways-under-the-influence-of-ml-193-a-technical-guide)

Disclaimer & Data Validity:

The information provided in this document is for Research Use Only (RUO) and is strictly not intended for diagnostic or therapeutic procedures. While BenchChem strives to provide accurate protocols, we make no warranties, express or implied, regarding the fitness of this product for every specific experimental setup.

Technical Support: The protocols provided are for reference purposes. Unsure if this reagent suits your experiment?

Need Industrial/Bulk Grade? [Request Custom Synthesis Quote](#)

BenchChem

Our mission is to be the trusted global source of essential and advanced chemicals, empowering scientists and researchers to drive progress in science and industry.

Contact

Address: 3281 E Guasti Rd

Ontario, CA 91761, United States

Phone: (601) 213-4426

Email: info@benchchem.com

[Contact our Ph.D. Support Team for a compatibility check](#)