

# Comparing the efficacy of Thalidomide-5-propargyl with lenalidomide-based PROTACs

**Author:** BenchChem Technical Support Team. **Date:** April 2026

## Compound of Interest

Compound Name: *Thalidomide-5-propargyl*

CAS No.: 2226303-74-6

Cat. No.: B15623514

[Get Quote](#)

## A Comparative Efficacy Analysis of Thalidomide- and Lenalidomide-Based PROTACs

In the rapidly advancing field of targeted protein degradation, Proteolysis Targeting Chimeras (PROTACs) have emerged as a powerful therapeutic modality. These heterobifunctional molecules leverage the cell's own ubiquitin-proteasome system to selectively eliminate disease-causing proteins. A critical component of many successful PROTACs is the E3 ligase-recruiting ligand, with derivatives of thalidomide and its analogue lenalidomide being widely employed to engage the Cereblon (CRBN) E3 ligase. This guide provides a detailed comparison of the efficacy of PROTACs constructed with thalidomide-based linkers, such as the readily available **Thalidomide-5-propargyl**, and those utilizing lenalidomide-based scaffolds.

## Performance Comparison: Degradation Efficiency

The central measure of a PROTAC's efficacy lies in its ability to induce the degradation of the target protein. This is typically quantified by the half-maximal degradation concentration (DC50) and the maximum level of degradation (Dmax). Comparative studies targeting the epigenetic

reader protein BRD4 have demonstrated that while both thalidomide and lenalidomide-based PROTACs can achieve potent degradation, lenalidomide-based degraders often exhibit superior potency.

PROTAC ID	E3 Ligase Ligand	Target Protein	DC50 (nM)	Dmax (%)	Reference
PROTAC 3	Thalidomide	BRD4	0.1 - 0.3	>90	[1]
PROTAC 4	Lenalidomide	BRD4	pM range	>90	[1]
PROTAC 5	Lenalidomide	BRD4	Not specified	>90	[1]

As indicated in the table, lenalidomide-based PROTACs can achieve picomolar (pM) potency in degrading BRD4, suggesting a potential efficacy advantage over thalidomide-based counterparts which demonstrate nanomolar (nM) activity.[1] It is important to note that the specific linker connecting the E3 ligase ligand to the target-binding moiety can significantly influence PROTAC performance.

Beyond potency, lenalidomide-based PROTACs may also possess more favorable physicochemical properties. The structural difference, specifically the absence of one of the phthalimide carbonyl groups in lenalidomide, can contribute to improved metabolic and chemical stability, which are critical factors for the overall in vivo performance of a PROTAC.[1]

## Signaling and Experimental Workflow Diagrams

To visually represent the underlying biological processes and experimental procedures, the following diagrams have been generated using the Graphviz DOT language.

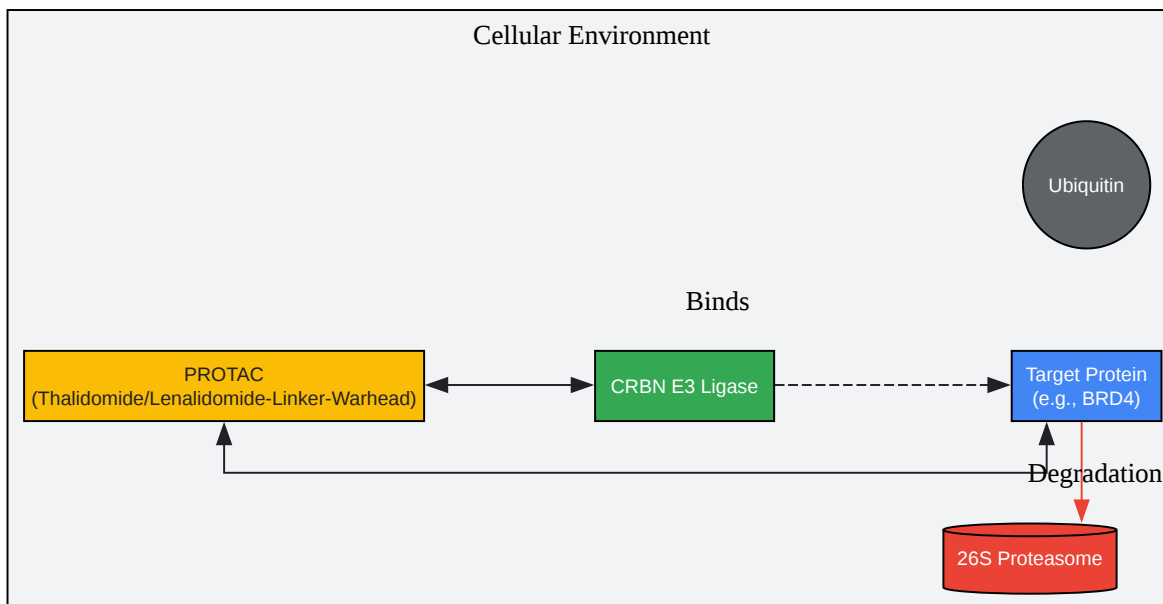

[Click to download full resolution via product page](#)

Caption: Mechanism of action of a CRBN-recruiting PROTAC.

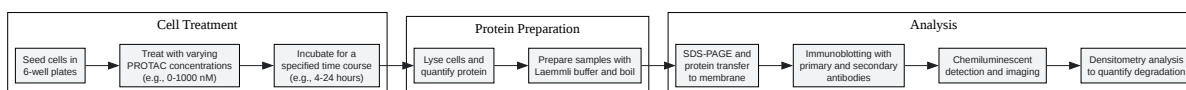

[Click to download full resolution via product page](#)

Caption: Experimental workflow for Western Blot analysis of PROTAC-mediated degradation.

## Experimental Protocols

Detailed methodologies are crucial for the accurate assessment and comparison of PROTAC efficacy. Below are protocols for key experiments.

## Western Blot Analysis of Protein Degradation

This protocol outlines the steps to quantify the degradation of a target protein, such as BRD4, in cultured cells following PROTAC treatment.[1]

### Materials and Reagents:

- Cell Line: A human cancer cell line expressing the target protein (e.g., THP-1, MDA-MB-231 for BRD4).
- PROTACs: Stock solutions of thalidomide- and lenalidomide-based PROTACs in DMSO.
- Controls: DMSO (vehicle control), and a non-degrading inhibitor of the target protein as a negative control.
- Cell Culture Medium: Appropriate medium for the chosen cell line (e.g., RPMI-1640).
- Lysis Buffer: RIPA buffer supplemented with protease and phosphatase inhibitors.
- Antibodies: Primary antibodies for the target protein (e.g., anti-BRD4) and a loading control (e.g., anti-GAPDH or anti- $\alpha$ -Tubulin), and a corresponding HRP-conjugated secondary antibody.
- Detection Reagent: Enhanced chemiluminescence (ECL) substrate.

### Procedure:

- Cell Seeding and Treatment:
  - Seed cells in 6-well plates to achieve 70-80% confluency at the time of harvest.
  - Allow cells to adhere overnight.
  - Treat cells with a range of PROTAC concentrations (e.g., 0, 10, 50, 100, 500, 1000 nM) for a predetermined time course (e.g., 4, 8, 16, 24 hours).[2] Include vehicle and negative

controls.

- Cell Lysis and Protein Quantification:
  - After treatment, wash cells with ice-cold PBS.
  - Add 100-200  $\mu$ L of ice-cold lysis buffer to each well and scrape the cells.
  - Incubate the lysate on ice for 30 minutes.
  - Centrifuge at 14,000 x g for 15 minutes at 4°C and collect the supernatant.
  - Determine the protein concentration using a BCA or Bradford assay.
- Sample Preparation and SDS-PAGE:
  - Normalize the protein concentration of all samples.
  - Add Laemmli sample buffer and boil at 95°C for 5-10 minutes.
  - Load equal amounts of protein (20-30  $\mu$ g) onto an SDS-PAGE gel.
- Protein Transfer and Immunoblotting:
  - Transfer proteins to a PVDF or nitrocellulose membrane.
  - Block the membrane with 5% non-fat dry milk or BSA in TBST for 1 hour.
  - Incubate with the primary antibody overnight at 4°C.
  - Wash the membrane with TBST and incubate with the HRP-conjugated secondary antibody for 1 hour at room temperature.
- Detection and Analysis:
  - Wash the membrane with TBST and add ECL substrate.
  - Capture the chemiluminescent signal.

- Quantify band intensities using densitometry software and normalize to the loading control. Calculate the percentage of protein degradation relative to the vehicle control to determine DC50 and Dmax values.

## Time-Resolved Fluorescence Energy Transfer (TR-FRET) Assay for Ternary Complex Formation

This assay is used to characterize the formation of the Target-PROTAC-E3 ligase ternary complex.[3]

### Materials and Reagents:

- Recombinant Proteins: GST-tagged target protein (e.g., GST-BRD2(BD1)) and His-tagged CRBN complex (e.g., His-CRBN(DDB1)).
- Detection Reagents: Terbium (Tb)-conjugated anti-GST antibody (donor) and AF488-conjugated anti-His antibody (acceptor).
- PROTACs and Ligands: Stock solutions of PROTACs and individual ligands (for target and E3 ligase) in DMSO.
- Assay Buffer: 50 mM Tris (pH 7.5), 0.01% Triton X-100, 0.01% BSA, 1 mM DTT.

### Procedure:

- Reagent Preparation:
  - Prepare dilutions of PROTACs and control ligands in assay buffer.
  - Prepare mixtures of the recombinant proteins and their corresponding labeled antibodies.
- Assay Plate Setup:
  - In a 384-well plate, add the PROTAC dilutions.
  - Dispense a mixture of the GST-tagged target protein and the Tb-anti-GST antibody.
  - Dispense a mixture of the His-tagged CRBN complex and the AF488-anti-His antibody.

- Final concentrations for a BRD2(BD1)/PROTAC/CRBN assay could be: 2 nM Tb-anti-GST, 2 nM GST-BRD2(BD1), 8 nM His-CRBN(DDB1), and 4 nM AF488-anti-His.[4]
- Incubation and Measurement:
  - Incubate the plate in the dark for a specified time (e.g., 180 minutes).
  - Measure the TR-FRET signal using a plate reader capable of time-resolved fluorescence measurements, with excitation at 340 nm and emission at 520 nm (acceptor) and 495 nm (donor).
- Data Analysis:
  - Calculate the TR-FRET ratio (Acceptor emission / Donor emission).
  - Plot the TR-FRET ratio against the PROTAC concentration. The resulting bell-shaped curve indicates ternary complex formation, with the peak representing the maximal efficacy concentration.

## Conclusion

Both thalidomide- and lenalidomide-based linkers are effective in recruiting the CRBN E3 ligase for targeted protein degradation. However, available data suggests that lenalidomide-based PROTACs may offer advantages in terms of degradation potency and potentially more favorable physicochemical properties.[1] The choice between these scaffolds will ultimately depend on the specific target protein, the desired properties of the final PROTAC molecule, and the synthetic strategy. The experimental protocols and comparative data presented in this guide provide a foundation for researchers to make informed decisions in the design and optimization of novel CRBN-recruiting degraders.

### *Need Custom Synthesis?*

*BenchChem offers custom synthesis for rare earth carbides and specific isotopic labeling.*

*Email: [info@benchchem.com](mailto:info@benchchem.com) or [Request Quote Online](#).*

## References

- [1. benchchem.com \[benchchem.com\]](https://www.benchchem.com)
- [2. researchgate.net \[researchgate.net\]](https://www.researchgate.net)
- [3. General Stepwise Approach to Optimize a TR-FRET Assay for Characterizing the BRD/PROTAC/CRBN Ternary Complex - PMC \[pmc.ncbi.nlm.nih.gov\]](https://pubmed.ncbi.nlm.nih.gov/36123514/)
- [4. pubs.acs.org \[pubs.acs.org\]](https://pubs.acs.org)
- To cite this document: BenchChem. [Comparing the efficacy of Thalidomide-5-propargyl with lenalidomide-based PROTACs]. BenchChem, [2026]. [Online PDF]. Available at: [<https://www.benchchem.com/product/b15623514/docs#comparing-the-efficacy-of-thalidomide-5-propargyl-with-lenalidomide-based-protacs>]

---

### Disclaimer & Data Validity:

The information provided in this document is for Research Use Only (RUO) and is strictly not intended for diagnostic or therapeutic procedures. While BenchChem strives to provide accurate protocols, we make no warranties, express or implied, regarding the fitness of this product for every specific experimental setup.

**Technical Support:** The protocols provided are for reference purposes. Unsure if this reagent suits your experiment?

**Need Industrial/Bulk Grade?** [Request Custom Synthesis Quote](#)

## BenchChem

Our mission is to be the trusted global source of essential and advanced chemicals, empowering scientists and researchers to drive progress in science and industry.

### Contact

Address: 3281 E Guasti Rd  
Ontario, CA 91761, United States  
Phone: (601) 213-4426  
Email: [info@benchchem.com](mailto:info@benchchem.com)

Contact our Ph.D. Support Team for a compatibility check