

# Application Notes and Protocols for Measuring MTHFD2 Inhibition in Intact Cells

**Author:** BenchChem Technical Support Team. **Date:** April 2026

## Compound of Interest

Compound Name: MTHFD2-IN-4

Cat. No.: B15623325

[Get Quote](#)

For Researchers, Scientists, and Drug Development Professionals

## Introduction

Methylenetetrahydrofolate dehydrogenase 2 (MTHFD2) is a mitochondrial enzyme crucial to one-carbon (1C) metabolism. It catalyzes the NAD<sup>+</sup>-dependent conversion of 5,10-methylenetetrahydrofolate to 10-formyltetrahydrofolate, a key step in providing one-carbon units for the synthesis of nucleotides (purines and thymidylate) and other essential biomolecules.[1] MTHFD2 is highly expressed in embryonic tissues and a wide array of cancer cells but is notably absent in most healthy adult tissues.[2][3] This differential expression makes MTHFD2 a compelling therapeutic target in oncology, as its inhibition could selectively disrupt the metabolic processes of rapidly proliferating cancer cells while sparing normal cells.[2][4]

Verifying that a potential inhibitor engages MTHFD2 within the complex environment of an intact cell is a critical step in drug development. This document provides detailed protocols for several established techniques to measure MTHFD2 inhibition and target engagement directly and indirectly in a cellular context.

## MTHFD2's Role in Mitochondrial One-Carbon Metabolism

MTHFD2 is a central enzyme in the mitochondrial folate cycle. This pathway utilizes serine as the primary source of one-carbon units, which are transferred to tetrahydrofolate (THF) to form 5,10-methylene-THF. MTHFD2 then converts this intermediate into 10-formyl-THF, which can be used to produce formate. Formate is subsequently exported to the cytoplasm to participate in the de novo synthesis of purines.[5][6] Inhibition of MTHFD2 disrupts this flow, leading to nucleotide depletion, replication stress, and ultimately, cancer cell death.[7]

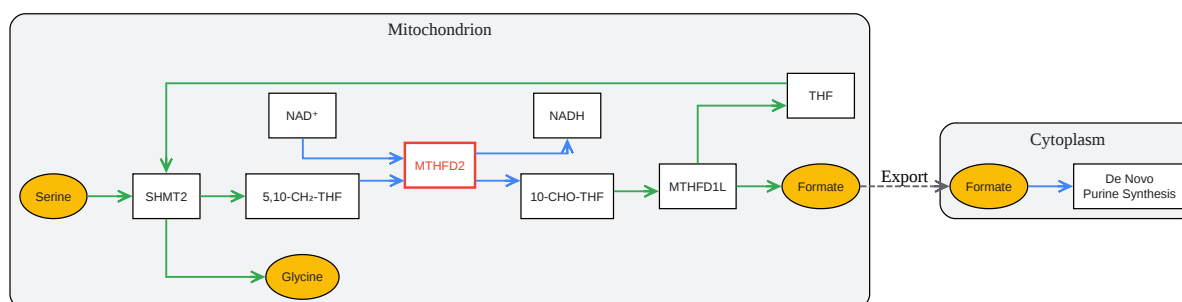

[Click to download full resolution via product page](#)

**Figure 1:** Simplified MTHFD2 metabolic pathway in the mitochondrion.

## Technique 1: Cellular Thermal Shift Assay (CETSA)

**Application Note:** The Cellular Thermal Shift Assay (CETSA) is a powerful method to directly verify target engagement in intact cells.[8] The principle is based on ligand-induced thermal stabilization of the target protein.[9] When a compound binds to its protein target, the resulting complex is often more resistant to thermal denaturation. In a CETSA experiment, cells treated with a compound are heated across a range of temperatures. The amount of soluble (non-

denatured) MTHFD2 remaining at each temperature is quantified, typically by Western blot. A positive target engagement is indicated by a shift in the melting curve to higher temperatures for the compound-treated cells compared to the vehicle control.[10][11]

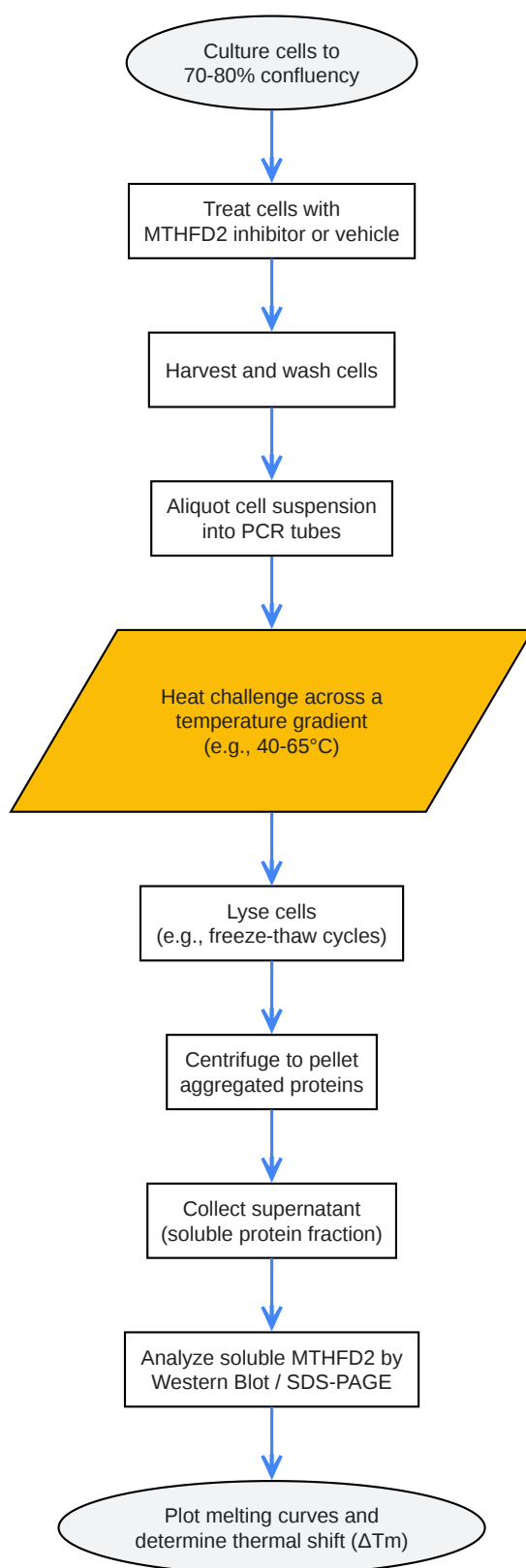

[Click to download full resolution via product page](#)

**Figure 2:** Experimental workflow for the Cellular Thermal Shift Assay (CETSA).

## Detailed Protocol:

- Cell Culture and Treatment:
  - Culture an appropriate cancer cell line known to express MTHFD2 (e.g., MOLM-14, MDA-MB-231) to 70-80% confluency.
  - Treat cells with the desired concentration of the MTHFD2 inhibitor or vehicle control (e.g., DMSO) for a specified time (e.g., 1-2 hours) at 37°C.[10]
- Cell Harvesting:
  - Harvest cells by trypsinization or scraping.
  - Wash the cells twice with ice-cold PBS and pellet by centrifugation (e.g., 300 x g for 5 minutes).
  - Resuspend the cell pellet in PBS containing protease inhibitors to a final concentration of  $\sim 1-2 \times 10^7$  cells/mL.[12]
- Heat Challenge:
  - Aliquot 50-100  $\mu$ L of the cell suspension into individual PCR tubes for each temperature point.
  - Place the PCR tubes in a thermal cycler and heat for 3 minutes at a range of temperatures (e.g., from 40°C to 65°C in 2-3°C increments). Include an unheated control sample (room temperature or 37°C).[9]
  - After the heating step, cool the samples to 4°C for 3 minutes.[9]
- Cell Lysis and Protein Fractionation:
  - Lyse the cells by performing 3-5 rapid freeze-thaw cycles using liquid nitrogen and a 37°C water bath.
  - Clarify the lysates by centrifugation at high speed (e.g., 20,000 x g) for 20 minutes at 4°C to pellet the aggregated proteins.[10]

- Carefully collect the supernatant, which contains the soluble protein fraction.
- Analysis:
  - Determine the protein concentration of the soluble fractions (e.g., using a BCA assay).
  - Normalize the protein concentrations for all samples.
  - Prepare samples for SDS-PAGE by adding Laemmli buffer and boiling.
  - Load equal amounts of protein onto an SDS-polyacrylamide gel and perform electrophoresis.
  - Transfer the proteins to a PVDF membrane and perform a Western blot using a primary antibody specific for MTHFD2 and a loading control (e.g., GAPDH,  $\beta$ -actin).[10]
  - Quantify the band intensities for MTHFD2 and the loading control.
- Data Presentation:
  - For each temperature point, calculate the fraction of soluble MTHFD2 relative to the unheated control.
  - Plot the fraction of soluble MTHFD2 against the temperature for both the vehicle- and compound-treated samples to generate melting curves. The shift in the midpoint of the curve ( $T_m$ ) indicates target stabilization.

## Technique 2: Metabolite Quantification Assays

Application Note: Measuring changes in the levels of metabolites upstream or downstream of MTHFD2 provides a functional readout of enzyme inhibition in intact cells. A direct consequence of MTHFD2 inhibition is a reduction in the production of mitochondrial formate.[5] [13] This can be measured using commercially available colorimetric assay kits. Alternatively, more sophisticated stable isotope tracing methods using labeled serine can quantify the flux through the entire mitochondrial 1C pathway.[14][15] Inhibition of MTHFD2 is expected to decrease the incorporation of the label into downstream products like purines or thymidine.

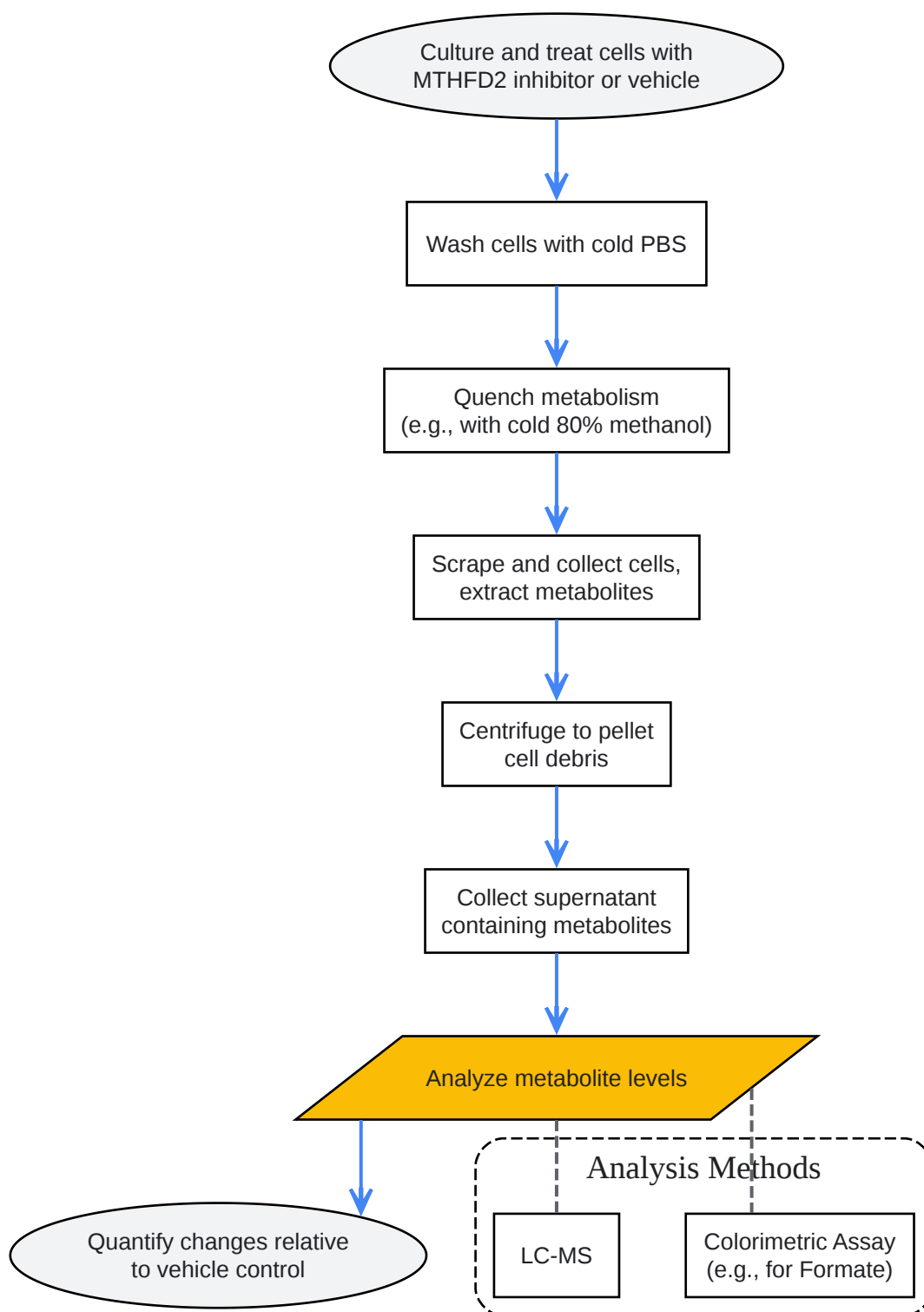

[Click to download full resolution via product page](#)

**Figure 3:** General workflow for metabolite extraction and analysis.

#### Detailed Protocol (Formate Assay):

- Cell Culture and Treatment:
  - Seed cells (e.g.,  $1-2 \times 10^6$  cells) in appropriate culture plates and allow them to adhere.
  - Treat cells with the MTHFD2 inhibitor or vehicle for the desired duration (e.g., 24-48 hours).
- Sample Preparation:
  - Harvest the cells and wash them with cold PBS.
  - Homogenize or lyse the cell pellet ( $\sim 1 \times 10^6$  cells) in 100  $\mu$ L of the assay buffer provided with a commercial formate assay kit (e.g., BioVision K653-100).[16]
  - Centrifuge the samples at high speed for 10 minutes to remove insoluble components.[16]
- Formate Measurement:
  - Transfer 50  $\mu$ L of the soluble fraction to a 96-well plate.
  - Add 50  $\mu$ L of the reaction buffer/mix from the kit to each well.
  - Incubate for 60 minutes at 37°C as per the manufacturer's instructions.[16]
  - Measure the absorbance or fluorescence using a microplate reader at the specified wavelength.
- Data Analysis:
  - Calculate the formate concentration in each sample based on a standard curve.
  - Normalize the formate concentration to the total protein content or cell number for each sample.
  - Compare the formate levels in inhibitor-treated cells to the vehicle-treated control.

## Technique 3: Cell Viability and Proliferation Assays

Application Note: Cell viability assays provide an indirect but essential measure of the functional consequences of MTHFD2 inhibition. Since MTHFD2 is critical for producing the building blocks required for rapid cell division, its inhibition is expected to reduce cancer cell proliferation and viability.<sup>[17]</sup> Standard methods like the MTT (3-(4,5-dimethylthiazol-2-yl)-2,5-diphenyltetrazolium bromide) assay, which measures metabolic activity, can be used to generate dose-response curves and determine the GI<sub>50</sub> (concentration for 50% growth inhibition) or IC<sub>50</sub> (concentration for 50% inhibition of viability) for a given compound.<sup>[18]</sup>

Detailed Protocol (MTT Assay):

- Cell Seeding:
  - Seed cells in a 96-well plate at a predetermined optimal density (e.g., 2,000-10,000 cells/well) and allow them to attach overnight.
- Compound Treatment:
  - Prepare serial dilutions of the MTHFD2 inhibitor in culture medium.
  - Remove the old medium from the cells and add 100 µL of the medium containing the inhibitor or vehicle control to the appropriate wells.
  - Incubate the plate for a specified period (e.g., 72 hours) at 37°C.
- MTT Addition and Incubation:
  - Add 10-20 µL of MTT solution (e.g., 5 mg/mL in PBS) to each well.
  - Incubate the plate for 2-4 hours at 37°C, allowing viable cells to convert the yellow MTT into purple formazan crystals.
- Formazan Solubilization:
  - Carefully remove the medium from each well.

- Add 100  $\mu$ L of a solubilization solution (e.g., DMSO or an isopropanol/HCl solution) to each well to dissolve the formazan crystals.[18]
- Mix thoroughly on a plate shaker.
- Data Acquisition and Analysis:
  - Measure the absorbance at a wavelength of  $\sim$ 570 nm using a microplate reader.[18]
  - Calculate the percentage of cell viability for each concentration relative to the vehicle control.
  - Plot the dose-response curve and use a four-parameter logistic equation to determine the  $GI_{50}$  or  $IC_{50}$  value.

## Quantitative Data for MTHFD2 Inhibitors

The following table summarizes publicly available data for several MTHFD2 inhibitors, providing a benchmark for comparison.  $IC_{50}$  values typically refer to biochemical enzymatic assays, while  $GI_{50}/EC_{50}$  values are derived from cellular proliferation or viability assays.

Inhibitor	Target(s)	MTHFD2 IC <sub>50</sub>	MTHFD1 IC <sub>50</sub>	Cellular Potency (GI <sub>50</sub> /EC <sub>50</sub> )	Reference(s)
DS18561882	MTHFD2 > MTHFD1	6.3 nM	570 nM	140 nM (MDA-MB-231)	[18][19][20]
LY345899	MTHFD1 > MTHFD2	663 nM	96 nM	630 nM (MOLM-14)	[5][13][14][18]
TH9619	MTHFD2, MTHFD1	47 nM	Potent Inhibition	Low nM range (HL-60)	[18]
TH7299	MTHFD1/2/2L	254 nM	89 nM (DC domain)	Not specified	[21]
LY374571	MTHFD2 > MTHFD1	80 nM	630 nM	Not specified	[4]
Compound [I]	MTHFD2 >> MTHFD1	66 nM	1790 nM	720 nM (MOLM-14)	[22]
Compound 16e	MTHFD2 >> MTHFD1	22 nM	120 nM	Not specified	[4]

### Need Custom Synthesis?

BenchChem offers custom synthesis for rare earth carbides and specific isotopic labeling.

Email: [info@benchchem.com](mailto:info@benchchem.com) or [Request Quote Online](#).

## References

- 1. MTHFD2- a new twist? - PMC [[pmc.ncbi.nlm.nih.gov](https://pubmed.ncbi.nlm.nih.gov/)]
- 2. What are MTHFD2 inhibitors and how do they work? [[synapse.patsnap.com](https://synapse.patsnap.com/)]
- 3. Metabolic enzyme expression highlights a key role for MTHFD2 and the mitochondrial folate pathway in cancer - PMC [[pmc.ncbi.nlm.nih.gov](https://pubmed.ncbi.nlm.nih.gov/)]

- [4. pubs.acs.org \[pubs.acs.org\]](https://pubs.acs.org)
- [5. More Than a Metabolic Enzyme: MTHFD2 as a Novel Target for Anticancer Therapy? - PMC \[pmc.ncbi.nlm.nih.gov\]](https://pubmed.ncbi.nlm.nih.gov/)
- [6. aacrjournals.org \[aacrjournals.org\]](https://aacrjournals.org)
- [7. eprints.whiterose.ac.uk \[eprints.whiterose.ac.uk\]](https://eprints.whiterose.ac.uk)
- [8. Screening for Target Engagement using the Cellular Thermal Shift Assay - CETSA - Assay Guidance Manual - NCBI Bookshelf \[ncbi.nlm.nih.gov\]](https://pubmed.ncbi.nlm.nih.gov/)
- [9. benchchem.com \[benchchem.com\]](https://benchchem.com)
- [10. benchchem.com \[benchchem.com\]](https://benchchem.com)
- [11. news-medical.net \[news-medical.net\]](https://www.news-medical.net)
- [12. benchchem.com \[benchchem.com\]](https://benchchem.com)
- [13. aacrjournals.org \[aacrjournals.org\]](https://aacrjournals.org)
- [14. aacrjournals.org \[aacrjournals.org\]](https://aacrjournals.org)
- [15. eprints.whiterose.ac.uk \[eprints.whiterose.ac.uk\]](https://eprints.whiterose.ac.uk)
- [16. p53 deficiency induces MTHFD2 transcription to promote cell proliferation and restrain DNA damage - PMC \[pmc.ncbi.nlm.nih.gov\]](https://pubmed.ncbi.nlm.nih.gov/)
- [17. The folate-coupled enzyme MTHFD2 is a nuclear protein and promotes cell proliferation - PMC \[pmc.ncbi.nlm.nih.gov\]](https://pubmed.ncbi.nlm.nih.gov/)
- [18. benchchem.com \[benchchem.com\]](https://benchchem.com)
- [19. researchgate.net \[researchgate.net\]](https://www.researchgate.net)
- [20. medchemexpress.com \[medchemexpress.com\]](https://www.medchemexpress.com)
- [21. The First Structure of Human MTHFD2L and Its Implications for the Development of Isoform-Selective Inhibitors - PMC \[pmc.ncbi.nlm.nih.gov\]](https://pubmed.ncbi.nlm.nih.gov/)
- [22. Potent, selective MTHFD2 inhibitor shows favorable PK and antitumor efficacy in AML models | BioWorld \[bioworld.com\]](https://www.bioworld.com)
- To cite this document: BenchChem. [Application Notes and Protocols for Measuring MTHFD2 Inhibition in Intact Cells]. BenchChem, [2026]. [Online PDF]. Available at: [\[https://www.benchchem.com/product/b15623325/docs#application-notes-and-protocols-for-measuring-mthfd2-inhibition-in-intact-cells\]](https://www.benchchem.com/product/b15623325/docs#application-notes-and-protocols-for-measuring-mthfd2-inhibition-in-intact-cells)

---

**Disclaimer & Data Validity:**

The information provided in this document is for Research Use Only (RUO) and is strictly not intended for diagnostic or therapeutic procedures. While BenchChem strives to provide accurate protocols, we make no warranties, express or implied, regarding the fitness of this product for every specific experimental setup.

**Technical Support:** The protocols provided are for reference purposes. Unsure if this reagent suits your experiment?

**Need Industrial/Bulk Grade?** [Request Custom Synthesis Quote](#)

## BenchChem

Our mission is to be the trusted global source of essential and advanced chemicals, empowering scientists and researchers to drive progress in science and industry.

### Contact

Address: 3281 E Guasti Rd  
Ontario, CA 91761, United States  
Phone: (601) 213-4426  
Email: [info@benchchem.com](mailto:info@benchchem.com)

[Contact our Ph.D. Support Team for a compatibility check](#)