

Application Notes and Protocols for In Vitro Studies with Micropeptin 478A

Author: BenchChem Technical Support Team. **Date:** April 2026

Compound of Interest

Compound Name: *Micropeptin 478A*

Cat. No.: *B15623814*

[Get Quote](#)

For Researchers, Scientists, and Drug Development Professionals

Introduction

Micropeptin 478A is a cyclic depsipeptide isolated from the cyanobacterium *Microcystis aeruginosa* (NIES-478).[1] As a member of the micropeptin class of cyanobacterial peptides, it has garnered interest for its potent biological activities. This document provides detailed application notes and protocols for in vitro studies involving **Micropeptin 478A**, with a focus on its serine protease inhibitory activity and potential anti-inflammatory effects.

Micropeptin 478A has been identified as a potent inhibitor of plasmin, a crucial serine protease involved in fibrinolysis and the regulation of blood coagulation.[1] Its high specificity makes it a valuable tool for studying the physiological and pathological roles of plasmin. Furthermore, the inhibition of plasmin suggests potential therapeutic applications in conditions characterized by excessive fibrinolysis or inflammation.

Data Presentation

The inhibitory activity of **Micropeptin 478A** has been quantified against a panel of serine proteases. The following table summarizes the available data.

Enzyme	IC50 (µg/mL)	Notes
Plasmin	0.1	Potent inhibition observed.
Trypsin	> 10.0	No significant inhibition.
Thrombin	> 10.0	No significant inhibition.
Papain	> 10.0	No significant inhibition.
Chymotrypsin	> 10.0	No significant inhibition.
Elastase	> 10.0	No significant inhibition.

Table 1: Inhibitory activity of **Micropeptin 478A** against various proteases. Data sourced from Ishida et al., 1997.[1]

Experimental Protocols

Plasmin Inhibition Assay (Chromogenic Substrate Method)

This protocol describes a method to determine the inhibitory activity of **Micropeptin 478A** against human plasmin using a chromogenic substrate. The assay is based on the ability of plasmin to cleave the chromogenic substrate, releasing a colored product (p-nitroaniline), which can be quantified spectrophotometrically. The presence of an inhibitor will reduce the rate of color development.

Materials:

- Human Plasmin
- **Micropeptin 478A**
- Chromogenic Plasmin Substrate (e.g., S-2251: H-D-Val-Leu-Lys-p-Nitroanilide)[2][3][4][5]
- Tris-HCl buffer (e.g., 0.05 M, pH 7.4)
- 96-well microplate

- Microplate reader capable of measuring absorbance at 405 nm
- Dimethyl sulfoxide (DMSO) for dissolving **Micropeptin 478A**

Procedure:

- Preparation of Reagents:
 - Prepare a stock solution of Human Plasmin in Tris-HCl buffer. The final concentration in the assay will depend on the specific activity of the enzyme lot and should be optimized for a linear rate of substrate hydrolysis.
 - Prepare a stock solution of **Micropeptin 478A** in DMSO.
 - Prepare a series of dilutions of **Micropeptin 478A** in Tris-HCl buffer from the stock solution. Ensure the final DMSO concentration in the assay wells is low (e.g., <1%) to avoid solvent effects.
 - Prepare the chromogenic substrate solution in Tris-HCl buffer according to the manufacturer's instructions.
- Assay Protocol:
 - To each well of a 96-well microplate, add the following in the specified order:
 - Tris-HCl buffer
 - **Micropeptin 478A** solution at various concentrations (or buffer for the control)
 - Human Plasmin solution
 - Incubate the plate at 37°C for a pre-determined time (e.g., 10-15 minutes) to allow the inhibitor to interact with the enzyme.
 - Initiate the reaction by adding the chromogenic substrate solution to each well.
 - Immediately measure the absorbance at 405 nm in a kinetic mode for a set period (e.g., 5-10 minutes) at 37°C.

- Data Analysis:
 - Calculate the initial rate of reaction (V) for each concentration of the inhibitor by determining the slope of the linear portion of the absorbance versus time curve.
 - Plot the percentage of inhibition against the logarithm of the inhibitor concentration.
 - Determine the IC₅₀ value, which is the concentration of the inhibitor that causes 50% inhibition of the enzyme activity, by fitting the data to a suitable dose-response curve.

Signaling Pathway and Experimental Workflow Visualization

Experimental Workflow for Plasmin Inhibition Assay

The following diagram illustrates the key steps in the in vitro plasmin inhibition assay.

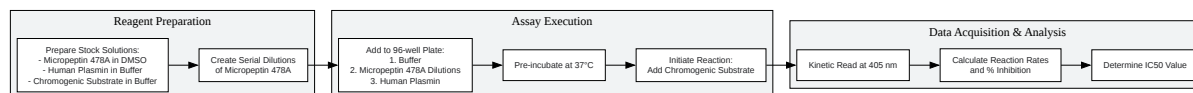

[Click to download full resolution via product page](#)

Caption: Workflow for determining the IC₅₀ of **Micropeptin 478A** against plasmin.

Postulated Anti-Inflammatory Signaling Pathway

The inhibition of plasmin by **Micropeptin 478A** may lead to anti-inflammatory effects by modulating downstream signaling pathways. Plasmin is known to activate various cellular responses that contribute to inflammation, in part through the activation of protease-activated receptors (PARs) and the subsequent activation of the NF- κ B signaling pathway.[6] By inhibiting plasmin, **Micropeptin 478A** could potentially suppress the activation of this pro-inflammatory cascade.

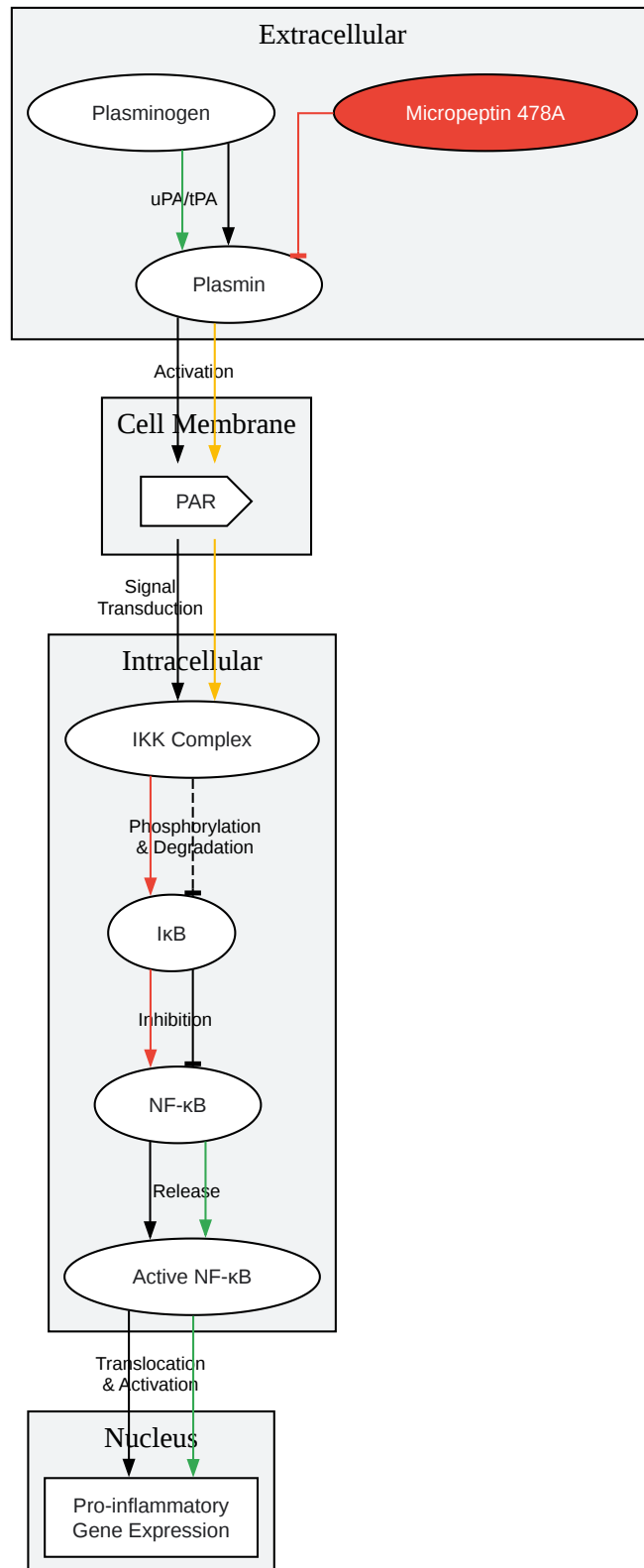

[Click to download full resolution via product page](#)

Caption: Proposed mechanism of anti-inflammatory action of **Micropeptin 478A** via plasmin inhibition.

Need Custom Synthesis?

BenchChem offers custom synthesis for rare earth carbides and specific isotopic labeling.

Email: info@benchchem.com or [Request Quote Online](#).

References

- [1. pubs.acs.org \[pubs.acs.org\]](https://pubs.acs.org)
- [2. endotell.ch \[endotell.ch\]](https://endotell.ch)
- [3. Modification of the immediate plasmin inhibition assay to secure linearity of the reference curve with the chromogenic substrate S-2251 - PubMed \[pubmed.ncbi.nlm.nih.gov\]](#)
- [4. endotell.ch \[endotell.ch\]](https://endotell.ch)
- [5. Use of chromogenic substrate S-2251 for determination of plasminogen activator in rat ovaries - PubMed \[pubmed.ncbi.nlm.nih.gov\]](#)
- [6. The multifaceted role of plasminogen in inflammation - PMC \[pmc.ncbi.nlm.nih.gov\]](#)
- To cite this document: BenchChem. [Application Notes and Protocols for In Vitro Studies with Micropeptin 478A]. BenchChem, [2026]. [Online PDF]. Available at: [\[https://www.benchchem.com/product/b15623814/docs#application-notes-and-protocols-for-in-vitro-studies-with-micropeptin-478a\]](https://www.benchchem.com/product/b15623814/docs#application-notes-and-protocols-for-in-vitro-studies-with-micropeptin-478a)

Disclaimer & Data Validity:

The information provided in this document is for Research Use Only (RUO) and is strictly not intended for diagnostic or therapeutic procedures. While BenchChem strives to provide accurate protocols, we make no warranties, express or implied, regarding the fitness of this product for every specific experimental setup.

Technical Support: The protocols provided are for reference purposes. Unsure if this reagent suits your experiment?

Need Industrial/Bulk Grade? [Request Custom Synthesis Quote](#)

BenchChem

Our mission is to be the trusted global source of essential and advanced chemicals, empowering scientists and researchers to drive progress in science and industry.

Contact

Address: 3281 E Guasti Rd
Ontario, CA 91761, United States
Phone: (601) 213-4426
Email: info@benchchem.com

[Contact our Ph.D. Support Team for a compatibility check](#)