

# how to reduce Mag-Fluo-4 AM background fluorescence

**Author:** BenchChem Technical Support Team. **Date:** April 2026

## Compound of Interest

Compound Name: *Mag-Fluo-4 AM*

Cat. No.: *B15622455*

[Get Quote](#)

## Technical Support Center: Mag-Fluo-4 AM

Welcome to the technical support center for **Mag-Fluo-4 AM**. This resource provides troubleshooting guides and frequently asked questions (FAQs) to help researchers, scientists, and drug development professionals optimize their experiments and overcome common challenges associated with this fluorescent indicator.

## Frequently Asked Questions (FAQs)

Q1: What are the main causes of high background fluorescence when using **Mag-Fluo-4 AM**?

High background fluorescence with **Mag-Fluo-4 AM** can stem from several factors:

- **Incomplete de-esterification:** The AM ester form of the dye is not fluorescent. However, incomplete cleavage of the AM groups by intracellular esterases can lead to partially de-esterified forms that have a lower affinity for  $\text{Ca}^{2+}$  and may contribute to background signal[1][2][3].
- **Dye leakage:** Once de-esterified, the negatively charged Mag-Fluo-4 can leak out of the cells. This extracellular dye can bind to calcium in the medium, contributing to a high

background signal[1][2]. Organic anion transporters can facilitate this leakage[1][4].

- Autofluorescence: Cells and culture medium components can exhibit natural fluorescence, which can add to the background noise[5].
- Subcellular compartmentalization: The dye may accumulate in organelles other than the intended target, leading to non-specific signals[6][7].
- Excess dye concentration: Using a higher-than-necessary concentration of **Mag-Fluo-4 AM** can result in residual, unwashed dye and increased background[7][8].
- Poor cell health: Damaged or dying cells may have elevated resting calcium levels, leading to a bright baseline fluorescence[5].

Q2: How can I reduce dye leakage from the cells?

To minimize the leakage of de-esterified Mag-Fluo-4, it is recommended to use an organic anion transporter (OAT) inhibitor, such as probenecid. Probenecid blocks the transporters responsible for extruding the negatively charged dye from the cytoplasm, thereby improving intracellular retention and reducing extracellular background fluorescence[4][9][10][11].

Q3: What is the role of Pluronic® F-127 in the loading protocol?

Pluronic® F-127 is a non-ionic surfactant that aids in the dispersion of the water-insoluble **Mag-Fluo-4 AM** in aqueous media. This helps to ensure a more uniform and efficient loading of the dye into the cells[1][8][9].

## Troubleshooting Guides

This section provides solutions to specific issues you may encounter during your experiments with **Mag-Fluo-4 AM**.

### Issue 1: High Background Fluorescence

High background fluorescence can obscure the specific signal from intracellular calcium changes. Here are some steps to troubleshoot this issue:

Potential Cause	Recommended Solution
Incomplete De-esterification	Optimize incubation time and temperature. Allow sufficient time (e.g., 30 minutes) after loading for complete de-esterification of the AM ester[7].
Dye Leakage	Include probenecid (typically 1-2.5 mM) in the incubation and imaging buffers to inhibit organic anion transporters[4][9][12].
Extracellular Dye Fluorescence	Wash cells thoroughly with fresh buffer after loading to remove excess extracellular dye[9][13]. Consider using a quenching antibody, like an anti-fluorescein antibody, to reduce the fluorescence of leaked indicator[1][2][3].
Excess Dye Concentration	Titrate the Mag-Fluo-4 AM concentration to the lowest effective level for your cell type (typically 2-5 $\mu$ M)[9][13].
Autofluorescence	Image a sample of unstained cells under the same conditions to determine the level of intrinsic autofluorescence. If significant, consider using a background subtraction algorithm.
Poor Cell Health	Ensure cells are healthy and not overgrown before starting the experiment. Minimize exposure to DMSO, which can be toxic to cells[14].

## Issue 2: Low or No Signal

A weak or absent fluorescent signal can be due to several factors related to dye loading and cell health.

Potential Cause	Recommended Solution
Inefficient Dye Loading	Optimize loading conditions, including Mag-Fluo-4 AM concentration (try a range of 2-20 $\mu\text{M}$ ), incubation time (30-60 minutes), and temperature (room temperature or 37°C)[9][15]. Ensure the use of a high-quality, anhydrous DMSO for preparing the stock solution[9][13]. Use Pluronic® F-127 (e.g., 0.02-0.04%) to improve dye solubility[1][9].
Cellular Esterase Activity	If esterase activity is low, you may need to increase the loading time or temperature to facilitate the cleavage of the AM esters.
Incorrect Filter Sets	Verify that you are using the appropriate excitation and emission filters for Mag-Fluo-4 (Ex/Em $\approx$ 490/525 nm)[9][13].
Cell Type Specificity	Some cell lines may be more difficult to load. Empirical optimization of loading parameters is crucial for each cell type[9][13].

## Experimental Protocols

### Key Experimental Methodologies

Below is a general protocol for loading cells with **Mag-Fluo-4 AM**. Note that optimal conditions may vary depending on the cell type and experimental setup.

#### 1. Preparation of Solutions:

- **Mag-Fluo-4 AM Stock Solution:** Prepare a 2 to 5 mM stock solution of **Mag-Fluo-4 AM** in high-quality, anhydrous DMSO[9][13].
- **Loading Buffer:** Prepare a working solution of 2-10  $\mu\text{M}$  **Mag-Fluo-4 AM** in a suitable buffer (e.g., Hanks' Balanced Salt Solution with HEPES - HHBS)[9][15]. For improved dye loading, 0.02-0.04% Pluronic® F-127 can be included[1][9]. To reduce dye leakage, 1-2.5 mM probenecid can also be added[9][12].

## 2. Cell Loading:

- Culture cells to the desired confluence on a suitable plate or coverslip.
- Remove the culture medium and wash the cells once with the loading buffer.
- Add the **Mag-Fluo-4 AM** working solution to the cells.
- Incubate for 30-60 minutes at 37°C or room temperature. The optimal time and temperature should be determined empirically[9][13].

## 3. Washing and De-esterification:

- After incubation, remove the loading solution and wash the cells 2-3 times with fresh, warm buffer (e.g., HHBS) to remove extracellular dye. The wash buffer can also be supplemented with probenecid[9].
- Incubate the cells in fresh buffer for an additional 30 minutes to allow for complete de-esterification of the dye within the cells[7].

## 4. Fluorescence Measurement:

- Measure fluorescence using a fluorescence microscope, plate reader, or flow cytometer with the appropriate filter set (Excitation ~490 nm, Emission ~525 nm)[9][13].

# Visualizations

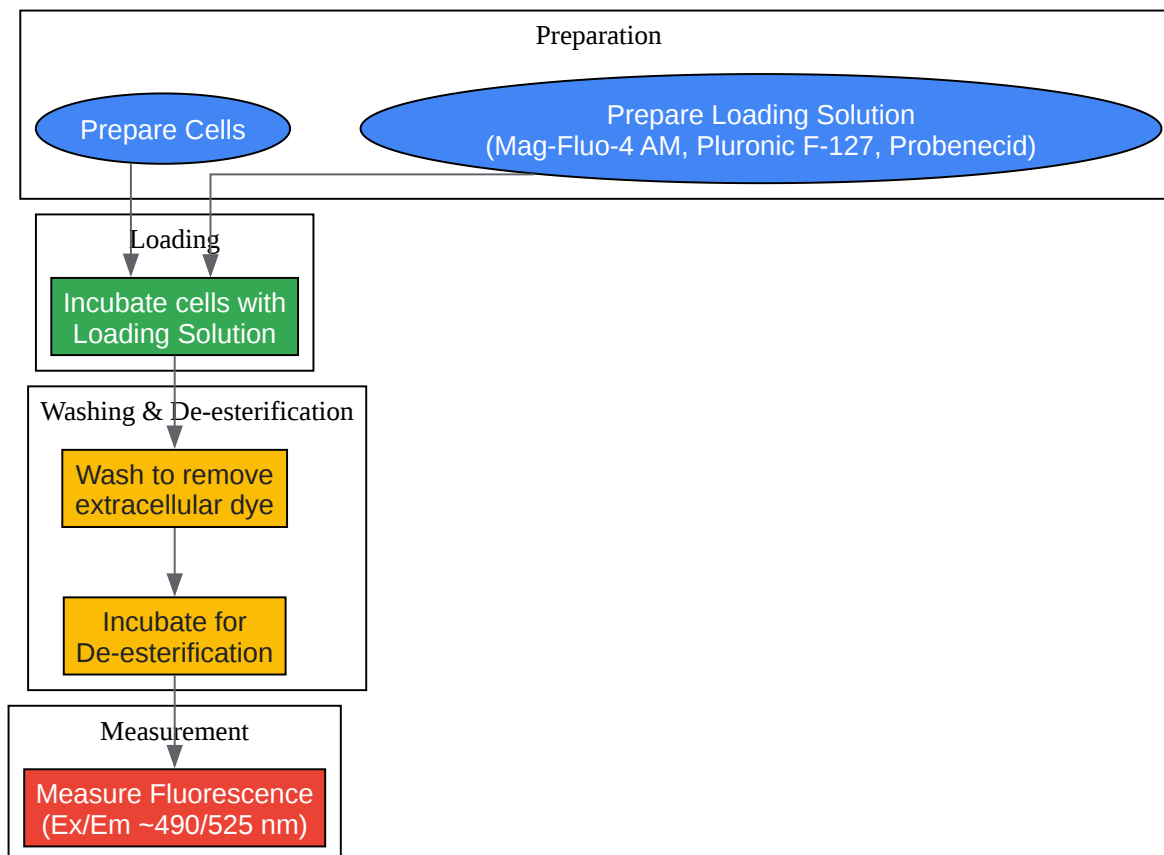

[Click to download full resolution via product page](#)

Caption: Experimental workflow for loading cells with **Mag-Fluo-4 AM**.

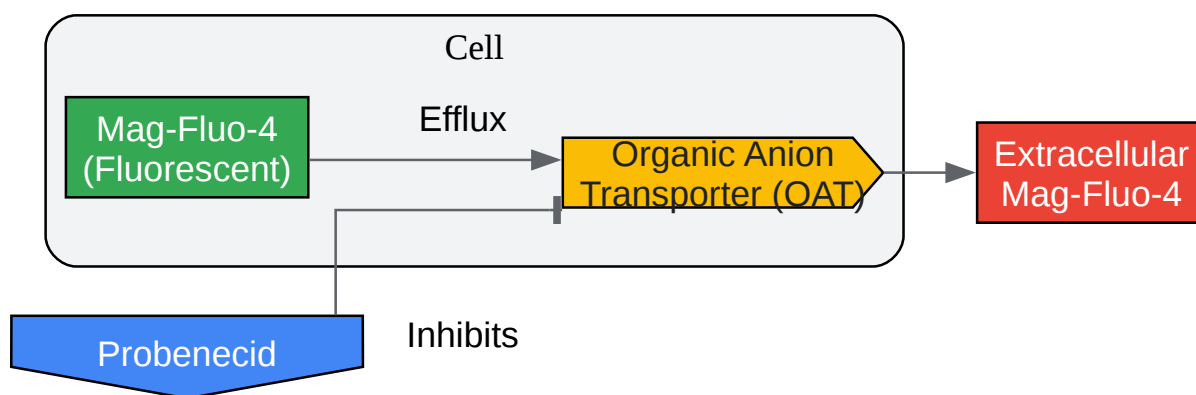

[Click to download full resolution via product page](#)

Caption: Mechanism of Probenecid in reducing Mag-Fluo-4 leakage.

### Need Custom Synthesis?

BenchChem offers custom synthesis for rare earth carbides and specific isotopic labeling.

Email: [info@benchchem.com](mailto:info@benchchem.com) or [Request Quote Online](#).

## References

- [1. Reliable measurement of free Ca<sup>2+</sup> concentrations in the ER lumen using Mag-Fluo-4 - PMC \[pmc.ncbi.nlm.nih.gov\]](#)
- [2. researchgate.net \[researchgate.net\]](#)
- [3. Reliable measurement of free Ca<sup>2+</sup> concentrations in the ER lumen using Mag-Fluo-4 - PubMed \[pubmed.ncbi.nlm.nih.gov\]](#)
- [4. researchgate.net \[researchgate.net\]](#)
- [5. researchgate.net \[researchgate.net\]](#)
- [6. researchgate.net \[researchgate.net\]](#)
- [7. interchim.fr \[interchim.fr\]](#)
- [8. apexbt.com \[apexbt.com\]](#)
- [9. docs.aatbio.com \[docs.aatbio.com\]](#)

- [10. A novel Ca<sup>2+</sup> indicator for long-term tracking of intracellular calcium flux - PubMed \[pubmed.ncbi.nlm.nih.gov\]](#)
- [11. researchgate.net \[researchgate.net\]](#)
- [12. api.repository.cam.ac.uk \[api.repository.cam.ac.uk\]](#)
- [13. docs.aatbio.com \[docs.aatbio.com\]](#)
- [14. How do I minimize cell damage during Fluo-4 AM loading? | AAT Bioquest \[aatbio.com\]](#)
- [15. medchemexpress.com \[medchemexpress.com\]](#)
- To cite this document: BenchChem. [how to reduce Mag-Fluo-4 AM background fluorescence]. BenchChem, [2026]. [Online PDF]. Available at: [\[https://www.benchchem.com/product/b15622455/docs#how-to-reduce-mag-fluo-4-am-background-fluorescence\]](https://www.benchchem.com/product/b15622455/docs#how-to-reduce-mag-fluo-4-am-background-fluorescence)

---

#### Disclaimer & Data Validity:

The information provided in this document is for Research Use Only (RUO) and is strictly not intended for diagnostic or therapeutic procedures. While BenchChem strives to provide accurate protocols, we make no warranties, express or implied, regarding the fitness of this product for every specific experimental setup.

**Technical Support:** The protocols provided are for reference purposes. Unsure if this reagent suits your experiment?

**Need Industrial/Bulk Grade?** [Request Custom Synthesis Quote](#)

## BenchChem

Our mission is to be the trusted global source of essential and advanced chemicals, empowering scientists and researchers to drive progress in science and industry.

#### Contact

Address: 3281 E Guasti Rd

Ontario, CA 91761, United States

Phone: (601) 213-4426

Email: [info@benchchem.com](mailto:info@benchchem.com)

Contact our Ph.D. Support Team for a compatibility check