

Technical Support Center: UCM05 Stability and Degradation

Author: BenchChem Technical Support Team. **Date:** April 2026

Compound of Interest

Compound Name: UCM05
Cat. No.: B15622751

[Get Quote](#)

This guide is intended for researchers, scientists, and drug development professionals using the investigational compound **UCM05**. It provides essential information regarding its long-term storage, potential degradation pathways, and analytical procedures to ensure the integrity of your experimental results.

Frequently Asked Questions (FAQs)

Q1: What are the recommended storage conditions for **UCM05**?

A1: To ensure long-term stability, solid **UCM05** should be stored at -20°C in a tightly sealed container, protected from light and moisture.^[1] Aliquoting stock solutions into single-use volumes is highly recommended to avoid repeated freeze-thaw cycles.^[1] For short-term storage (less than 72 hours), solutions may be kept at 4°C.

Q2: What are the primary causes and signs of **UCM05** degradation?

A2: **UCM05** contains an ester functional group, making it primarily susceptible to hydrolysis, which is the cleavage of chemical bonds by water.^{[2][3][4][5][6]} This process is accelerated by exposure to moisture, non-neutral pH, and elevated temperatures.^{[3][7][8][9]} Other potential

degradation pathways include oxidation and photolysis (degradation due to light exposure).[5][7][10][11]

Visual signs of degradation in solid **UCM05** can include a change in color or texture. For **UCM05** solutions, degradation may be indicated by cloudiness, precipitation, or a color change.[1] However, significant degradation can occur without any visible changes.

Q3: How can I verify the integrity of my **UCM05** sample?

A3: The most reliable method to assess the purity and integrity of **UCM05** is through analytical chromatography.[1] A stability-indicating High-Performance Liquid Chromatography (HPLC) method is recommended to separate and quantify **UCM05** from its potential degradation products.[10][12] Liquid Chromatography-Mass Spectrometry (LC-MS) can be used to confirm the identity of **UCM05** and its degradants by analyzing their mass-to-charge ratios.[12][13]

Q4: What are the known degradation products of **UCM05**?

A4: Based on forced degradation studies, the primary degradation pathway for **UCM05** is hydrolysis, yielding two main products: **UCM05-Acid** and **UCM05-Alcohol**. Under oxidative stress (e.g., exposure to hydrogen peroxide), a minor degradation product, **UCM05-N-Oxide**, has also been observed.

UCM05 Degradation Pathway

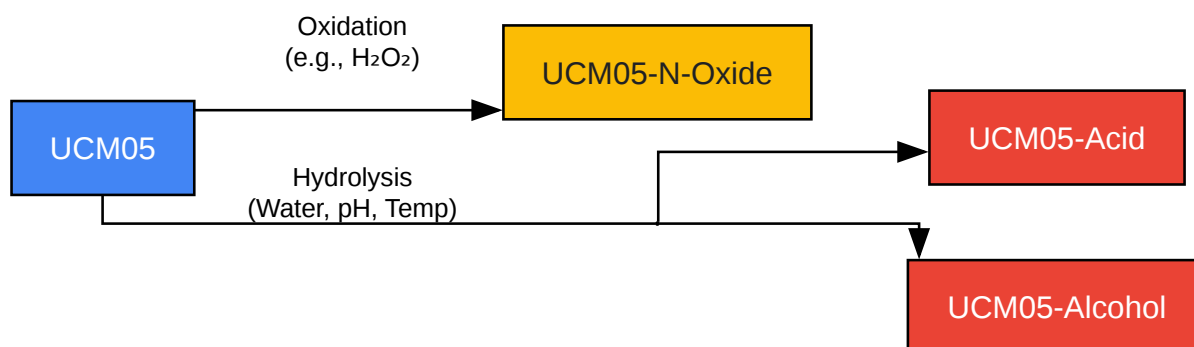

[Click to download full resolution via product page](#)

Caption: Hydrolytic and oxidative degradation pathways of **UCM05**.

Troubleshooting Guide

Symptom / Observation	Potential Cause	Recommended Actions
Inconsistent or lower-than-expected biological activity.	Degradation of UCM05 has led to a reduced concentration of the active compound.	<ol style="list-style-type: none">1. Verify Purity: Analyze the purity of the UCM05 stock solution using a validated HPLC method.[1]2. Prepare Fresh Solutions: Prepare new working solutions from a fresh aliquot of solid UCM05 stored under recommended conditions.[1]3. Compare Batches: If possible, compare the performance of the suspect batch with a new, validated batch of UCM05.
New peaks observed in HPLC or LC-MS analysis.	The new peaks likely correspond to degradation products such as UCM05-Acid, UCM05-Alcohol, or UCM05-N-Oxide.	<ol style="list-style-type: none">1. Review Storage History: Check the storage conditions and age of the sample. Note any deviations from the recommended protocol, such as temperature fluctuations or light exposure.2. Perform Co-injection: If standards are available, co-inject the sample with known degradation products to confirm their identity.3. Conduct Forced Degradation: Perform a forced degradation study (see protocol below) to confirm if the observed peaks match those generated under stress conditions.[13]
Visible changes in solid compound or solution (e.g., color change, precipitation).	Significant chemical degradation or reduced solubility.	<ol style="list-style-type: none">1. Do Not Use: Discard the material as its integrity is compromised.[14]2. Review Handling Procedures: Ensure

that solvents used for stock solutions are anhydrous and that solutions are not exposed to incompatible materials. 3. Check Solubility: Consult the technical data sheet for solubility information and ensure you are not exceeding the solubility limit.

Stability Data Summary

The following tables summarize the stability of solid **UCM05** and a 10 mM **UCM05** solution in DMSO under various conditions. Purity was assessed by HPLC-UV at 254 nm.

Table 1: Stability of Solid **UCM05** After 12 Months

Storage Condition	Purity (%)	Appearance
-20°C, Dark, Desiccated	99.5%	White Crystalline Solid
4°C, Dark, Desiccated	97.1%	White Crystalline Solid
25°C, Ambient Light, Ambient Humidity	85.3%	Off-white Powder
40°C, Ambient Light, 75% RH	68.2%	Yellowish Powder

Table 2: Stability of **UCM05** in DMSO (10 mM) at 25°C

Time Point	Purity (%)
0 Hours	99.8%
24 Hours	99.6%
48 Hours	99.1%
72 Hours	98.5%
1 Week	94.2%

Experimental Protocols

Protocol 1: Stability-Indicating HPLC Method for UCM05

This protocol describes a reverse-phase HPLC (RP-HPLC) method capable of separating **UCM05** from its primary degradation products.

- Column: C18, 4.6 x 150 mm, 5 µm particle size
- Mobile Phase A: 0.1% Formic Acid in Water
- Mobile Phase B: 0.1% Formic Acid in Acetonitrile
- Gradient:
 - 0-2 min: 5% B
 - 2-15 min: 5% to 95% B
 - 15-18 min: 95% B
 - 18-18.1 min: 95% to 5% B
 - 18.1-22 min: 5% B
- Flow Rate: 1.0 mL/min
- Column Temperature: 30°C

- Detection Wavelength: 254 nm
- Injection Volume: 10 μ L
- Sample Preparation: Dilute **UCM05** samples in a 50:50 mixture of Acetonitrile:Water to a final concentration of 0.1 mg/mL.

Protocol 2: Forced Degradation Study of UCM05

Forced degradation studies are used to identify potential degradation products and establish the stability-indicating nature of an analytical method.[\[15\]](#)[\[16\]](#)

1. Preparation of Stock Solution: Prepare a 1 mg/mL stock solution of **UCM05** in acetonitrile.

2. Stress Conditions:

- Acid Hydrolysis: Mix 1 mL of stock solution with 1 mL of 0.1 N HCl. Incubate at 60°C for 24 hours.
- Base Hydrolysis: Mix 1 mL of stock solution with 1 mL of 0.1 N NaOH. Incubate at room temperature for 4 hours.
- Oxidative Degradation: Mix 1 mL of stock solution with 1 mL of 3% H₂O₂. Incubate at room temperature for 24 hours.
- Thermal Degradation: Store the solid **UCM05** powder at 80°C for 48 hours, then prepare a sample for analysis.
- Photolytic Degradation: Expose the stock solution in a quartz cuvette to a photostability chamber (UV and visible light) for 24 hours.[\[13\]](#)[\[15\]](#)

3. Sample Analysis: Before injection, neutralize the acidic and basic samples with an equivalent amount of base or acid, respectively. Dilute all stressed samples to a final concentration of approximately 0.1 mg/mL with 50:50 Acetonitrile:Water and analyze using the HPLC method described above.

Workflow and Pathway Visualizations

Experimental Workflow for Stability Testing

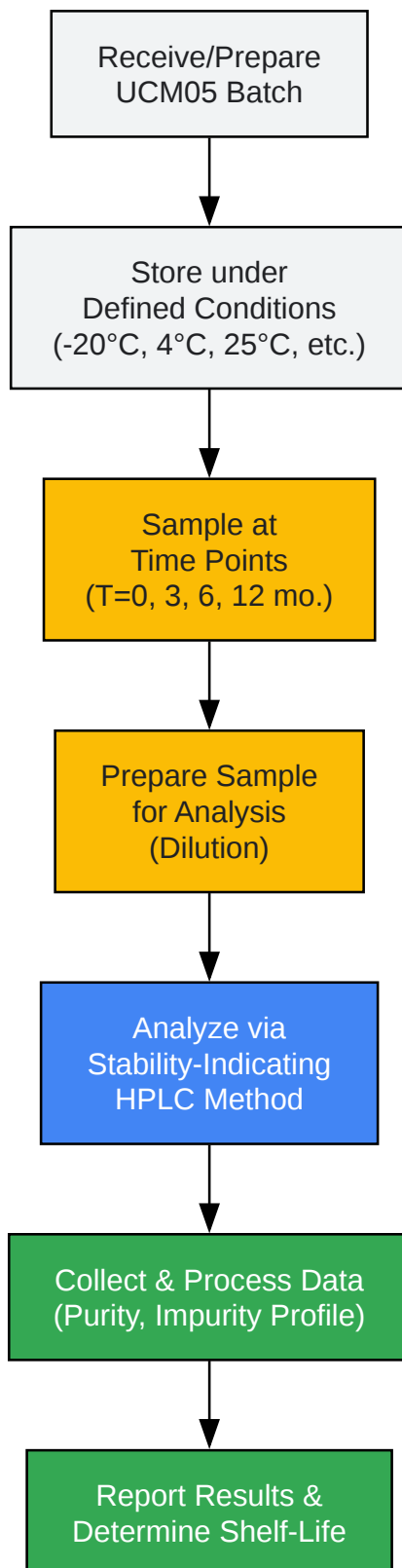

[Click to download full resolution via product page](#)

Caption: General workflow for a long-term stability study of **UCM05**.

Hypothetical Signaling Pathway Affected by **UCM05** Degradation

This diagram illustrates how the degradation of **UCM05** could impact experimental results in a hypothetical cell-based assay where **UCM05** is an inhibitor of Kinase B.

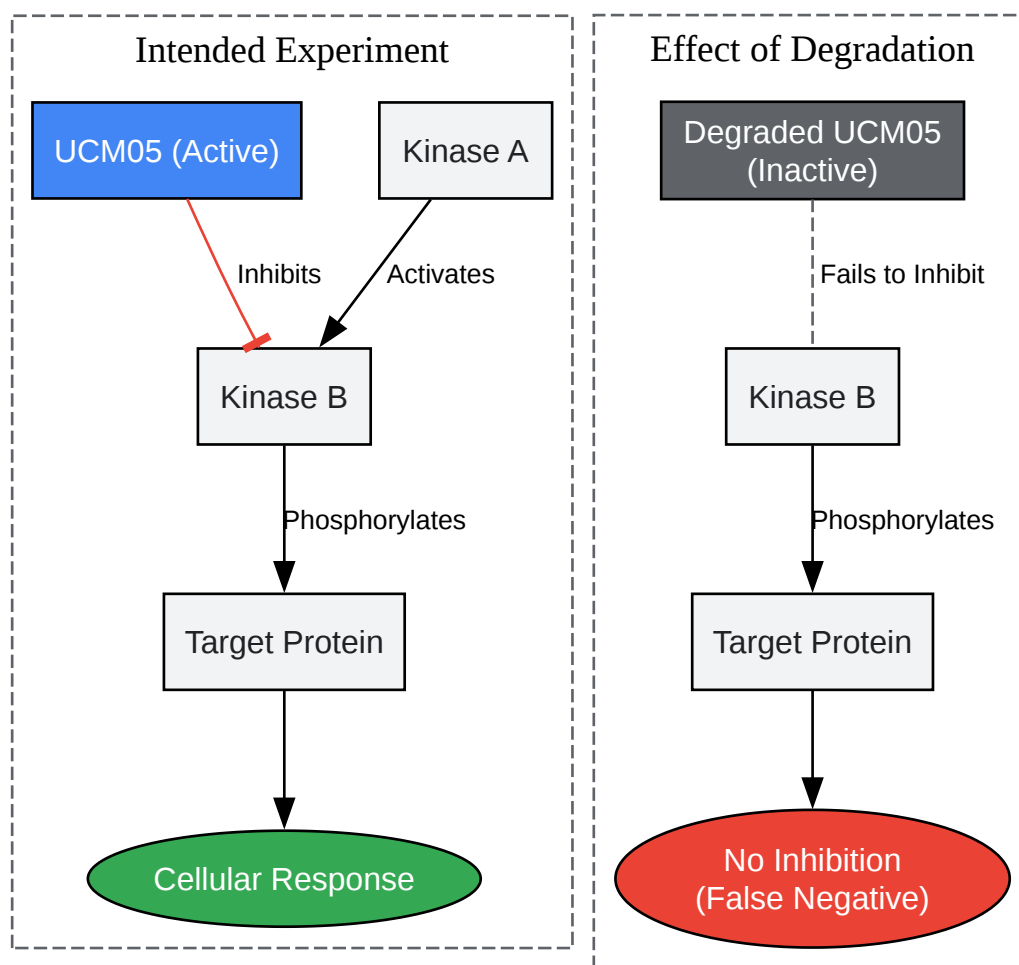

[Click to download full resolution via product page](#)

Caption: Impact of **UCM05** degradation on a hypothetical signaling pathway.

Need Custom Synthesis?

BenchChem offers custom synthesis for rare earth carbides and specific isotopic labeling.

Email: info@benchchem.com or [Request Quote Online](#).

References

- [1. benchchem.com \[benchchem.com\]](#)
- [2. benchchem.com \[benchchem.com\]](#)
- [3. benchchem.com \[benchchem.com\]](#)
- [4. pharmaceutical-journal.com \[pharmaceutical-journal.com\]](#)
- [5. moravek.com \[moravek.com\]](#)
- [6. pharmacy180.com \[pharmacy180.com\]](#)
- [7. scitechnol.com \[scitechnol.com\]](#)
- [8. Factors affecting stability of drugs | PPTX \[slideshare.net\]](#)
- [9. Factors affecting the stability of drugs and drug metabolites in biological matrices - PubMed \[pubmed.ncbi.nlm.nih.gov\]](#)
- [10. synthinkchemicals.com \[synthinkchemicals.com\]](#)
- [11. rjptonline.org \[rjptonline.org\]](#)
- [12. Analytical Techniques In Stability Testing | Separation Science \[sepscience.com\]](#)
- [13. benchchem.com \[benchchem.com\]](#)
- [14. Storage of Laboratory Chemicals: Research Safety: Environmental Health & Safety: Protect IU: Indiana University \[protect.iu.edu\]](#)
- [15. Development of forced degradation and stability indicating studies of drugs—A review - PMC \[pmc.ncbi.nlm.nih.gov\]](#)
- [16. resolvemass.ca \[resolvemass.ca\]](#)
- To cite this document: BenchChem. [Technical Support Center: UCM05 Stability and Degradation]. BenchChem, [2026]. [Online PDF]. Available at: [\[https://www.benchchem.com/product/b15622751/docs#technical-support-center-ucm05-stability-and-degradation\]](https://www.benchchem.com/product/b15622751/docs#technical-support-center-ucm05-stability-and-degradation)

Disclaimer & Data Validity:

The information provided in this document is for Research Use Only (RUO) and is strictly not intended for diagnostic or therapeutic procedures. While BenchChem strives to provide accurate protocols, we make no warranties, express or implied, regarding the fitness of this product for every specific experimental setup.

Technical Support: The protocols provided are for reference purposes. Unsure if this reagent suits your experiment?

Need Industrial/Bulk Grade? [Request Custom Synthesis Quote](#)

BenchChem

Our mission is to be the trusted global source of essential and advanced chemicals, empowering scientists and researchers to drive progress in science and industry.

Contact

Address: 3281 E Guasti Rd
Ontario, CA 91761, United States
Phone: (601) 213-4426
Email: info@benchchem.com

[Contact our Ph.D. Support Team for a compatibility check](#)