

Technical Support Center: Overcoming Microbial Resistance to Piperitenone Oxide

Author: BenchChem Technical Support Team. **Date:** April 2026

Compound of Interest

Compound Name: Piperitenone oxide

CAS No.: 5945-46-0

Cat. No.: B15622863

[Get Quote](#)

This technical support center provides researchers, scientists, and drug development professionals with troubleshooting guides and frequently asked questions (FAQs) for experiments involving **piperitenone oxide**. The information is presented in a question-and-answer format to directly address specific issues encountered during experimental workflows.

Frequently Asked Questions (FAQs)

Q1: What is **piperitenone oxide** and what is its antimicrobial potential?

Piperitenone oxide (PEO) is an oxygenated monoterpene found in the essential oils of various plants, particularly from the *Mentha* species.[1] It has demonstrated a range of biological activities, including antimicrobial effects against both Gram-positive and Gram-negative bacteria, as well as fungi like *Candida albicans*. [2] Its potential is being explored as a standalone antimicrobial agent and as a synergist to enhance the efficacy of conventional antibiotics.

Q2: What are the known mechanisms of action for **piperitenone oxide**?

The precise molecular mechanisms are still under investigation. However, like other essential oil components, the antimicrobial action of PEO is generally attributed to the disruption of the bacterial cytoplasmic membrane and interference with various cellular metabolic processes.[3] There is also evidence to suggest that related compounds can inhibit efflux pumps, which are a common mechanism of drug resistance in microbes.

Q3: What are the general mechanisms by which microbes develop resistance to compounds like **piperitenone oxide**?

Microbes can develop resistance to antimicrobial agents through several mechanisms, including:

- **Limiting Drug Uptake:** Altering the cell membrane's permeability to prevent the compound from entering the cell.[4]
- **Modification of the Drug Target:** Changing the structure of the cellular components that the antimicrobial agent targets.[4]
- **Drug Inactivation:** Producing enzymes that chemically modify and inactivate the antimicrobial compound.[4]
- **Active Efflux of the Drug:** Upregulating efflux pumps that actively pump the antimicrobial agent out of the cell before it can reach its target.[4]

Troubleshooting Experimental Assays

Minimum Inhibitory Concentration (MIC) Assay

Q4: I'm having trouble dissolving **piperitenone oxide** for my MIC assay. What should I do?

Piperitenone oxide is a lipophilic compound with low solubility in aqueous solutions like culture media.[5]

- **Solution:** Prepare a high-concentration stock solution in an organic solvent such as dimethyl sulfoxide (DMSO).[1][5] When preparing your working dilutions in the assay medium, ensure the final concentration of DMSO is low (typically below 0.5% to 1%) to avoid solvent-induced toxicity to the microbes.[5] Always include a solvent control to verify it does not affect microbial growth.

Q5: My MIC results for **piperitenone oxide** are inconsistent between experiments. What could be the cause?

Inconsistency in MIC results is a common challenge when working with natural products. Several factors can contribute to this variability.

- Possible Causes & Solutions:
 - Inoculum Preparation: Ensure the bacterial or fungal inoculum is standardized to the same density (e.g., 0.5 McFarland standard) for every experiment.
 - Compound Precipitation: **Piperitenone oxide** may precipitate when diluted from the DMSO stock into the aqueous assay medium. Visually inspect your dilutions for any signs of precipitation. Optimize your dilution protocol by performing serial dilutions or vortexing thoroughly at each step.^[5]
 - Pipetting Errors: Calibrate your pipettes regularly and ensure accurate and consistent pipetting, especially when performing serial dilutions.
 - Incubation Conditions: Maintain consistent incubation times and temperatures, as these can affect both microbial growth and the stability of the compound.

Checkerboard (Synergy) Assay

Q6: How do I interpret the results of my checkerboard assay with **piperitenone oxide** and an antibiotic?

The results are interpreted by calculating the Fractional Inhibitory Concentration (FIC) Index for each combination. The FIC Index is calculated as follows:

FIC Index = FIC of PEO + FIC of Antibiotic Where:

- FIC of PEO = (MIC of PEO in combination) / (MIC of PEO alone)
- FIC of Antibiotic = (MIC of Antibiotic in combination) / (MIC of Antibiotic alone)

The interaction is then classified based on the FIC Index value:

- Synergy: ≤ 0.5
- Additive: > 0.5 to 1.0
- Indifference: > 1.0 to 4.0
- Antagonism: > 4.0 ^[3]

Q7: I am observing "skipped wells" in my checkerboard plate, where there is growth at higher concentrations but not at lower ones. How should I interpret this?

This phenomenon can complicate interpretation.

- Possible Causes & Solutions:
 - Bacterial Clumping: Ensure your bacterial suspension is homogenous before inoculation.
 - Contamination: Review your sterile technique to rule out contamination.
 - Paradoxical Effect (Eagle Effect): Some antibiotics, particularly β -lactams, can show reduced activity at very high concentrations. If this is suspected, a time-kill assay can provide more detailed information on the interaction over time.

Biofilm Inhibition Assay

Q8: My results from the crystal violet biofilm assay are not reproducible. What are some common issues?

Biofilm assays with lipophilic compounds can be tricky.

- Possible Causes & Solutions:
 - Inadequate Washing: Inconsistent washing steps can leave behind planktonic cells or remove parts of the biofilm, leading to variability. Standardize your washing technique in terms of force and volume.
 - Compound Interference: **Piperitenone oxide** might interact with the plastic of the microtiter plate or the crystal violet stain. Include appropriate controls with the compound

in the absence of microbes to check for this.

- Growth Inhibition vs. Biofilm Inhibition: At higher concentrations, PEO might inhibit overall microbial growth, which can be mistaken for specific biofilm inhibition. It's crucial to differentiate between these two effects, for example, by measuring planktonic growth in parallel.

Quantitative Data Summary

The following tables summarize the available quantitative data on the antimicrobial and synergistic activity of **piperitenone oxide** and the related compound piperine.

Table 1: Minimum Inhibitory Concentration (MIC) of **Piperitenone Oxide** (PEO)

| Organism | Strain Type | Average MIC (µg/mL) | MIC Range (µg/mL) | Source |
|-----------------------|----------------------|---------------------|-------------------|--------|
| Staphylococcus aureus | 28 Clinical Isolates | 172.8 ± 180.7 | 32 - 1024 | [3] |
| Escherichia coli | 10 Clinical Isolates | 512.2 ± 364.7 | 32 - 1024 | [3] |
| Candida albicans | Not Specified | - | 390 - 780 | [2] |

Table 2: Synergistic Activity of **Piperitenone Oxide** (PEO) with Antibiotics against *S. aureus* and *E. coli*

| Organism | Antibiotic | Interaction Type | % of Strains Showing Synergy (FIC Index \leq 0.5) | Source |
|--------------|------------|------------------|---|--------|
| S. aureus | Ampicillin | Synergy | 57.14% | [6] |
| Ceftriaxone | Synergy | 67.86% | [6] | |
| Levofloxacin | Synergy | 67.86% | [6] | |
| Linezolid | Synergy | 67.86% | [6] | |
| Vancomycin | Synergy | 60.71% | [6] | |
| E. coli | Amikacin | Synergy | 100% | [6] |
| Ampicillin | Synergy | 100% | [6] | |
| Ceftazidime | Synergy | 100% | [6] | |
| Meropenem | Synergy | 100% | [6] | |
| Minocycline | Synergy | 100% | [6] | |

Table 3: Antimicrobial and Antibiofilm Activity of Piperine (as a proxy for PEO)

| Organism | Activity | Metric | Value ($\mu\text{g/mL}$) | Source |
|----------------------------------|--------------------|-------------------------|----------------------------|--------|
| Candida albicans (FLC-Resistant) | Antifungal | MIC | 512 | [7] |
| Candida albicans | Biofilm Inhibition | MBIC | 32 | [8] |
| Pseudomonas aeruginosa | Biofilm Inhibition | Effective Concentration | 8 - 16 | [9] |

Experimental Protocols

Protocol 1: Broth Microdilution Assay for MIC Determination

- Preparation of **Piperitenone Oxide**: Prepare a stock solution of PEO in DMSO (e.g., 10240 µg/mL).
- Plate Setup: In a 96-well microtiter plate, add 100 µL of Mueller-Hinton Broth (MHB) to each well. For experiments with PEO, supplement the MHB with DMSO to a final concentration that will not exceed 1% v/v in the wells.
- Serial Dilution: Add a specific volume of the PEO stock solution to the first column of wells to achieve the highest desired concentration. Perform two-fold serial dilutions across the plate.
- Inoculum Preparation: Prepare a bacterial suspension equivalent to a 0.5 McFarland standard (approximately 1.5×10^8 CFU/mL). Dilute this suspension to achieve a final concentration of 5×10^5 CFU/mL in each well.
- Inoculation: Add the diluted bacterial suspension to each well. Include a growth control (broth + bacteria, no PEO) and a sterility control (broth only).
- Incubation: Incubate the plate at 37°C for 16-24 hours.
- Endpoint Determination: The MIC is the lowest concentration of PEO with no visible growth. Growth can be assessed visually or by adding a viability dye like MTT or resazurin.[1]

Protocol 2: Checkerboard Assay for Synergy Testing

- Plate Setup: Prepare a 96-well plate by adding 50 µL of broth to each well.
- Antibiotic Dilution: Serially dilute Antibiotic A horizontally across the plate.
- PEO Dilution: Serially dilute PEO vertically down the plate. This creates a matrix of varying concentrations of both agents.
- Inoculation: Add 100 µL of a standardized bacterial inoculum (e.g., 5×10^5 CFU/mL) to each well.
- Controls: Include rows/columns with each agent alone to redetermine their individual MICs on the same plate. Also include growth and sterility controls.
- Incubation: Incubate the plate at 37°C for 16-24 hours.

- **Analysis:** Determine the MIC of each agent alone and in combination. Calculate the FIC index for each well showing inhibition to determine the nature of the interaction.

Protocol 3: Crystal Violet Biofilm Inhibition Assay

- **Inoculum and Treatment:** In a 96-well flat-bottom plate, add 100 μ L of standardized bacterial culture and 100 μ L of media containing various sub-MIC concentrations of PEO. Include a no-treatment control.
- **Incubation:** Incubate the plate at 37°C for 24-48 hours without agitation to allow biofilm formation.
- **Washing:** Carefully discard the planktonic culture and wash the wells gently with phosphate-buffered saline (PBS) to remove non-adherent cells.
- **Fixation:** Add 200 μ L of methanol to each well and incubate for 15 minutes to fix the biofilm.
- **Staining:** Discard the methanol and allow the plate to air dry. Add 200 μ L of 0.1% crystal violet solution to each well and incubate for 15 minutes.
- **Final Wash and Solubilization:** Discard the crystal violet solution and wash the wells thoroughly with water until the wash water is clear. Air dry the plate. Add 200 μ L of 33% acetic acid to each well to solubilize the stain.
- **Quantification:** Measure the absorbance at a wavelength of approximately 570 nm using a microplate reader.

Diagrams and Visualizations

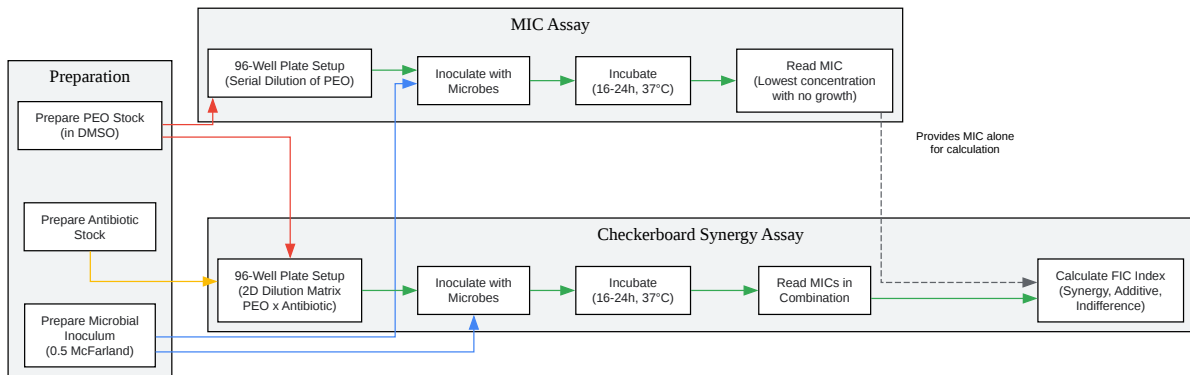

[Click to download full resolution via product page](#)

Caption: Workflow for MIC and Synergy Testing.

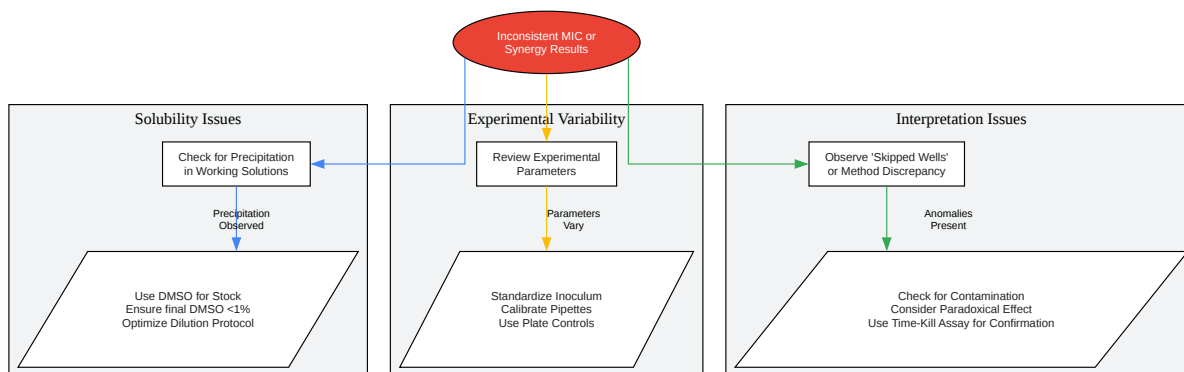

[Click to download full resolution via product page](#)

Caption: Troubleshooting Logic for Inconsistent Results.

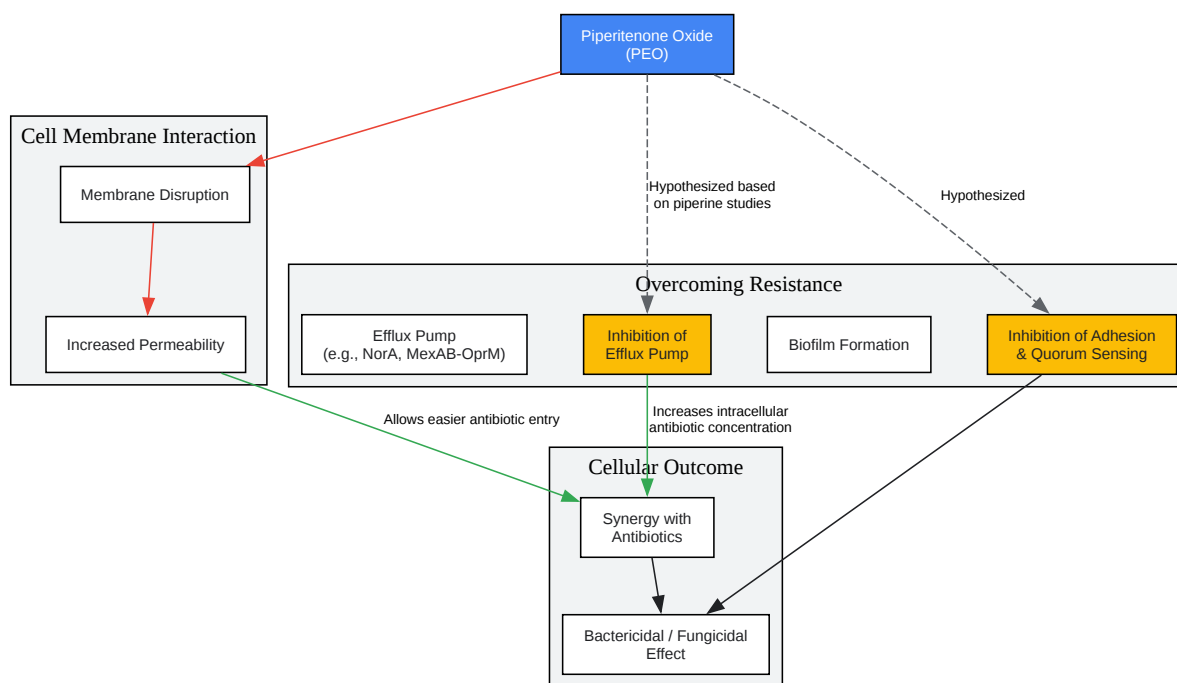

[Click to download full resolution via product page](#)

Caption: Hypothesized Mechanisms of Action for PEO.

Need Custom Synthesis?

BenchChem offers custom synthesis for rare earth carbides and specific isotopic labeling.

Email: info@benchchem.com or [Request Quote Online](#).

References

- [1. benchchem.com \[benchchem.com\]](https://www.benchchem.com)
- [2. Chemical Composition and Anti-Candida Activity of Mentha suaveolens Ehrh. Essential Oils Obtained by Different Distillation Processes - PMC \[pmc.ncbi.nlm.nih.gov\]](https://pubmed.ncbi.nlm.nih.gov/31111111/)
- [3. Combined Action of Piperitenone Epoxide and Antibiotics Against Clinical Isolates of Staphylococcus aureus and Escherichia coli - PMC \[pmc.ncbi.nlm.nih.gov\]](https://pubmed.ncbi.nlm.nih.gov/31111112/)
- [4. An overview of the antimicrobial resistance mechanisms of bacteria - PMC \[pmc.ncbi.nlm.nih.gov\]](https://pubmed.ncbi.nlm.nih.gov/31111113/)
- [5. benchchem.com \[benchchem.com\]](https://www.benchchem.com)
- [6. researchgate.net \[researchgate.net\]](https://www.researchgate.net)
- [7. Exploring the Potential Mechanism of Action of Piperine against Candida albicans and Targeting Its Virulence Factors - PMC \[pmc.ncbi.nlm.nih.gov\]](https://pubmed.ncbi.nlm.nih.gov/31111114/)
- [8. Synergistic Interaction of Piperine and Thymol on Attenuation of the Biofilm Formation, Hyphal Morphogenesis and Phenotypic Switching in Candida albicans - PubMed \[pubmed.ncbi.nlm.nih.gov\]](https://pubmed.ncbi.nlm.nih.gov/31111115/)
- [9. Piperine Exhibits Potential Antibiofilm Activity Against Pseudomonas aeruginosa by Accumulating Reactive Oxygen Species, Affecting Cell Surface Hydrophobicity and Quorum Sensing - PubMed \[pubmed.ncbi.nlm.nih.gov\]](https://pubmed.ncbi.nlm.nih.gov/31111116/)
- To cite this document: BenchChem. [Technical Support Center: Overcoming Microbial Resistance to Piperitenone Oxide]. BenchChem, [2026]. [Online PDF]. Available at: [\[https://www.benchchem.com/product/b15622863/docs#technical-support-center-overcoming-microbial-resistance-to-piperitenone-oxide\]](https://www.benchchem.com/product/b15622863/docs#technical-support-center-overcoming-microbial-resistance-to-piperitenone-oxide)

Disclaimer & Data Validity:

The information provided in this document is for Research Use Only (RUO) and is strictly not intended for diagnostic or therapeutic procedures. While BenchChem strives to provide accurate protocols, we make no warranties, express or implied, regarding the fitness of this product for every specific experimental setup.

Technical Support: The protocols provided are for reference purposes. Unsure if this reagent suits your experiment?

Need Industrial/Bulk Grade? [Request Custom Synthesis Quote](#)

BenchChem

Our mission is to be the trusted global source of essential and advanced chemicals, empowering scientists and researchers to drive progress in science and industry.

Contact

Address: 3281 E Guasti Rd

Ontario, CA 91761, United States

Phone: (601) 213-4426

Email: info@benchchem.com

[Contact our Ph.D. Support Team for a compatibility check](#)