

Technical Support Center: MCG-02 In Vivo Delivery

Author: BenchChem Technical Support Team. **Date:** April 2026

Compound of Interest

Compound Name: MCG-02
Cat. No.: B15622960

[Get Quote](#)

This technical support center provides comprehensive troubleshooting guides and frequently asked questions (FAQs) to assist researchers, scientists, and drug development professionals in navigating the challenges associated with the in vivo delivery of **MCG-02**.

Frequently Asked Questions (FAQs)

Q1: What is **MCG-02** and what is its primary mechanism of action?

A1: **MCG-02** is a novel therapeutic agent under investigation. While specific details of its mechanism are proprietary, it is understood to modulate key signaling pathways involved in disease progression. Successful in vivo delivery is critical to achieving its therapeutic effect.

Q2: What are the primary challenges encountered in the in vivo delivery of **MCG-02**?

A2: The main challenges with **MCG-02** revolve around its physicochemical properties, which can lead to poor aqueous solubility and potential for rapid clearance from the body.^[1] Like many advanced therapeutic agents, especially those formulated as nanoparticles, **MCG-02** faces several biological barriers that can limit its efficacy.^{[2][3]} These include uptake by the mononuclear phagocytic system (MPS), limited penetration across vascular endothelium, and potential for off-target effects.^{[2][4][5]}

Q3: My **MCG-02** formulation is precipitating. What can I do?

A3: Precipitation is a common issue for compounds with low aqueous solubility.[6][7] Several strategies can be employed to improve solubility and formulation stability. These include the use of co-solvents such as DMSO, though the final concentration should be minimized to avoid toxicity.[1] Other approaches involve utilizing surfactants or creating advanced formulations like nanoparticles to enhance bioavailability.[4][7]

Q4: I am observing inconsistent results between experiments. What could be the cause?

A4: Inconsistent results often suggest variable bioavailability of the compound.[6] This can stem from issues with the formulation, such as precipitation upon injection, or the route of administration.[1][6] It is also important to consider the health and uniformity of the animal models used in your studies. Pharmacokinetic studies are recommended to understand the absorption, distribution, metabolism, and excretion (ADME) profile of **MCG-02** in your model.[1][8]

Q5: Are there potential off-target effects I should be aware of with **MCG-02**?

A5: While **MCG-02** is designed for a specific target, it is crucial to consider and control for potential off-target effects in in vivo studies.[1] These can arise from the compound itself or the delivery vehicle. Careful experimental design, including appropriate control groups, is essential to differentiate between target-specific effects and off-target phenomena.

Troubleshooting Guides

This section provides a systematic approach to identifying and resolving common issues encountered during the in vivo delivery of **MCG-02**.

Table 1: Formulation and Administration Issues

Issue	Potential Cause	Recommended Solution
Precipitation of MCG-02 during formulation or upon injection	<ul style="list-style-type: none"> - Low aqueous solubility of MCG-02.[6] - Inappropriate vehicle for a hydrophobic compound.[6] 	<ul style="list-style-type: none"> - Utilize co-solvents like DMSO, keeping the final concentration low (<10%).[1] - Employ surfactants or other solubilizing agents.[6] - Consider nanoparticle-based formulations.[4][5]
Animal distress or adverse reactions post-injection	<ul style="list-style-type: none"> - Irritating formulation or rapid injection.[6] - High concentration of co-solvents (e.g., DMSO).[1] - Potential toxicity of the delivery vehicle or MCG-02 itself.[4] 	<ul style="list-style-type: none"> - Inject the solution slowly.[6] - Reduce the concentration of organic co-solvents.[1] - Evaluate alternative, less irritating vehicles.[6] - Conduct preliminary dose-escalation studies to determine maximum tolerated dose.
Inconsistent therapeutic efficacy	<ul style="list-style-type: none"> - Variable bioavailability due to formulation issues.[6] - Insufficient dose to reach the target tissue.[1] - Rapid metabolism and clearance of MCG-02.[1] 	<ul style="list-style-type: none"> - Optimize the formulation for improved stability and solubility.[6][7] - Perform a dose-response study to identify the optimal therapeutic dose.[1] - Conduct pharmacokinetic studies to assess the half-life of MCG-02.[1]
Lack of target engagement	<ul style="list-style-type: none"> - Poor penetration of MCG-02 across biological barriers.[2][3] - Uptake by the mononuclear phagocytic system (MPS).[2][4] - The dose may be too low to achieve the necessary concentration at the target site.[1] 	<ul style="list-style-type: none"> - Modify nanoparticle surface properties to enhance circulation time and reduce MPS uptake.[5] - Investigate strategies to actively transport nanoparticles across the vascular endothelium.[2][8] - Increase the administered dose after confirming safety.[1]

Experimental Protocols

General Protocol for Formulation of MCG-02 using a Co-Solvent System

This protocol provides a general guideline for formulating a poorly soluble compound like **MCG-02** for in vivo administration.

- Preparation of Vehicle: Prepare a sterile vehicle mixture. A common starting point for a hydrophobic compound is a mixture of DMSO, PEG400, and saline.[6] For a final formulation of 10% DMSO and 40% PEG400 in saline:
 - In a sterile microcentrifuge tube, add the required volume of DMSO.
- Dissolving **MCG-02**: Add the powdered **MCG-02** to the DMSO and vortex thoroughly until it is completely dissolved. Gentle warming or brief sonication may be necessary.[6]
- Homogenization: Add the PEG400 to the DMSO/**MCG-02** solution and vortex until the solution is homogeneous.[6]
- Final Dilution: Slowly add the sterile saline to the mixture while vortexing to prevent precipitation of the compound.[6]
- Visual Inspection: The final formulation should be a clear, particle-free solution.[6]

Protocol for Intravenous (Tail Vein) Injection in Mice

- Animal Preparation: Warm the mouse's tail using a heat lamp or warm water to dilate the lateral tail veins.[6]
- Restraint: Place the mouse in a suitable restraint device to secure the tail.
- Injection: Using a sterile insulin syringe with an appropriate gauge needle (e.g., 27-30G), slowly inject the prepared **MCG-02** formulation into one of the lateral tail veins.
- Monitoring: After injection, monitor the animal for any signs of distress or adverse reactions.
[6]

Visualizations

Hypothetical Signaling Pathway for MCG-02

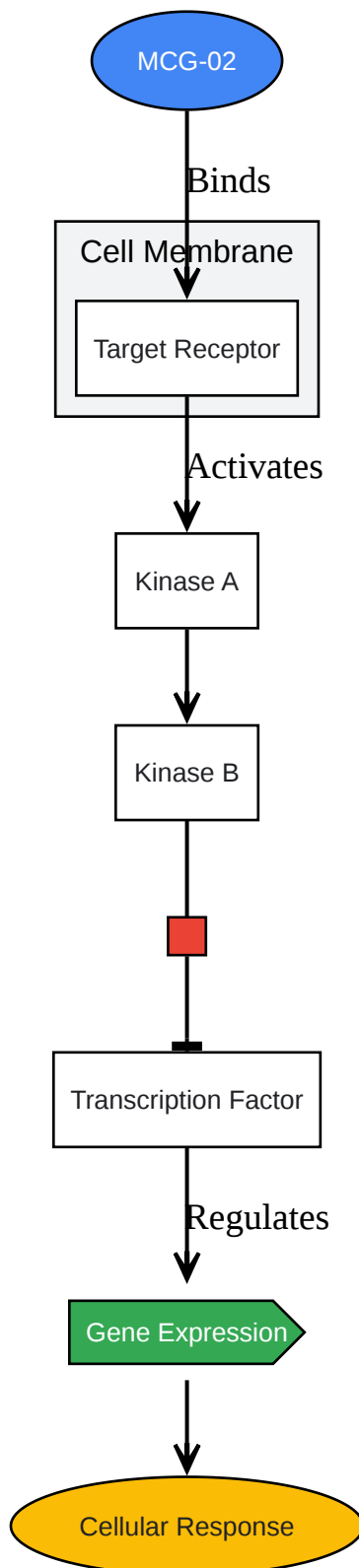

[Click to download full resolution via product page](#)

Caption: A simplified diagram of a hypothetical signaling pathway inhibited by **MCG-02**.

Experimental Workflow for Troubleshooting In Vivo Efficacy

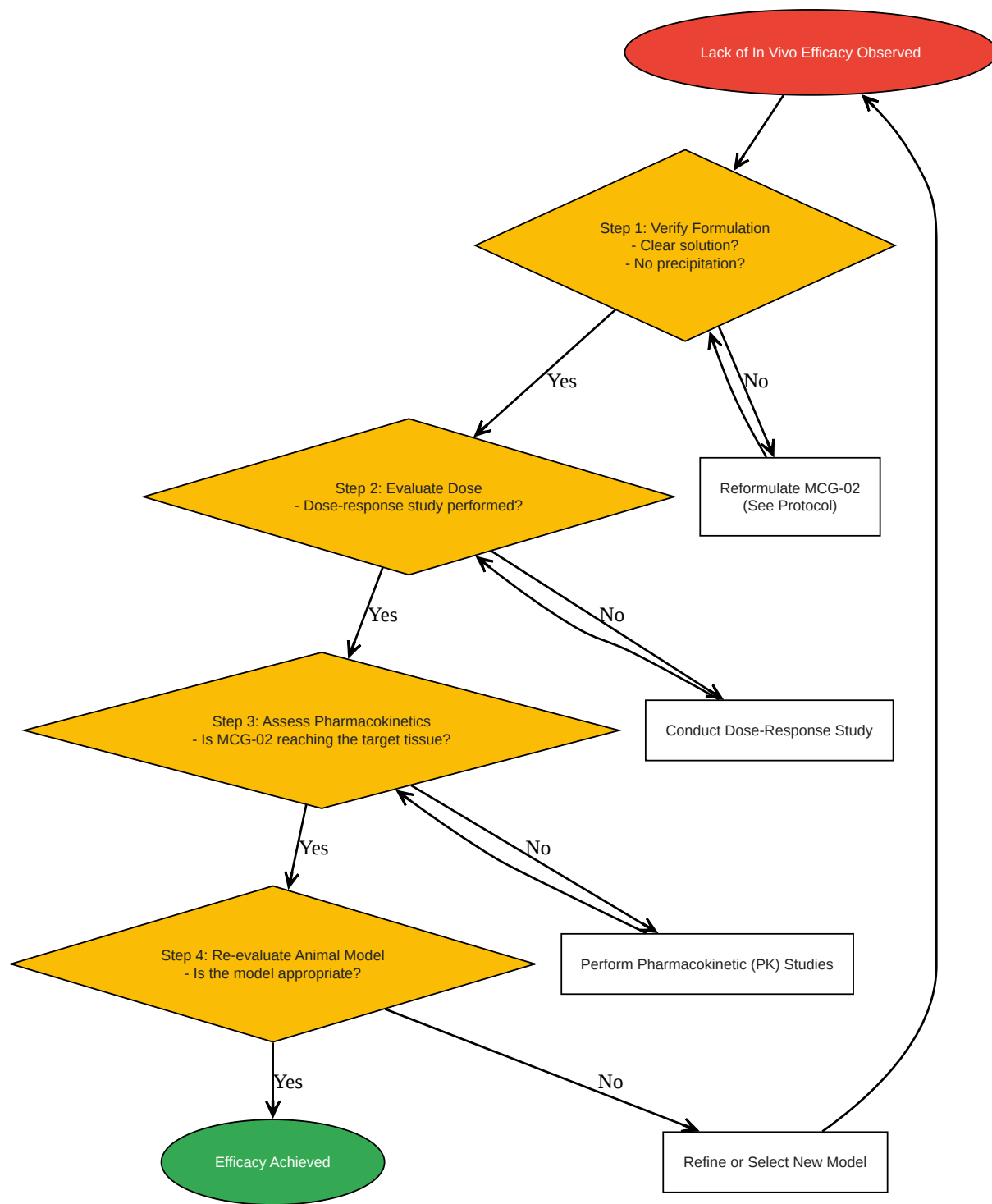

[Click to download full resolution via product page](#)

Caption: A logical workflow for troubleshooting the lack of in vivo efficacy with **MCG-02**.

Need Custom Synthesis?

BenchChem offers custom synthesis for rare earth carbides and specific isotopic labeling.

Email: info@benchchem.com or [Request Quote Online](#).

References

- [1. benchchem.com \[benchchem.com\]](https://www.benchchem.com)
- [2. Overcoming in vivo barriers to targeted nanodelivery. | Semantic Scholar \[semanticscholar.org\]](#)
- [3. Challenges associated with Penetration of Nanoparticles across Cell and Tissue Barriers: A Review of Current Status and Future Prospects - PMC \[pmc.ncbi.nlm.nih.gov\]](#)
- [4. Drug delivery and nanoparticles: Applications and hazards - PMC \[pmc.ncbi.nlm.nih.gov\]](#)
- [5. Challenges in Development of Nanoparticle-Based Therapeutics - PMC \[pmc.ncbi.nlm.nih.gov\]](#)
- [6. benchchem.com \[benchchem.com\]](https://www.benchchem.com)
- [7. benchchem.com \[benchchem.com\]](https://www.benchchem.com)
- [8. walshmedicalmedia.com \[walshmedicalmedia.com\]](https://www.walshmedicalmedia.com)
- To cite this document: BenchChem. [Technical Support Center: MCG-02 In Vivo Delivery]. BenchChem, [2026]. [Online PDF]. Available at: [\[https://www.benchchem.com/product/b15622960/docs#technical-support-center-mcg-02-in-vivo-delivery\]](https://www.benchchem.com/product/b15622960/docs#technical-support-center-mcg-02-in-vivo-delivery)

Disclaimer & Data Validity:

The information provided in this document is for Research Use Only (RUO) and is strictly not intended for diagnostic or therapeutic procedures. While BenchChem strives to provide accurate protocols, we make no warranties, express or implied, regarding the fitness of this product for every specific experimental setup.

Technical Support: The protocols provided are for reference purposes. Unsure if this reagent suits your experiment?

Need Industrial/Bulk Grade? [Request Custom Synthesis Quote](#)

BenchChem

Our mission is to be the trusted global source of essential and advanced chemicals, empowering scientists and researchers to drive progress in science and industry.

Contact

Address: 3281 E Guasti Rd

Ontario, CA 91761, United States

Phone: (601) 213-4426

Email: info@benchchem.com

[Contact our Ph.D. Support Team for a compatibility check](#)