

# Investigating the Oncogenic Functions of MASTL: A Technical Guide

**Author:** BenchChem Technical Support Team. **Date:** April 2026

## Compound of Interest

Compound Name: Mastl-IN-4

Cat. No.: B15622983

[Get Quote](#)

For Researchers, Scientists, and Drug Development Professionals

## Introduction

Microtubule-associated serine/threonine kinase-like (MASTL), also known as Greatwall (Gwl), has emerged as a critical regulator of mitotic progression and a key player in oncogenesis. Initially identified for its essential role in ensuring the fidelity of cell division, a growing body of evidence now implicates MASTL overexpression and hyperactivity in the development and progression of numerous cancers. Upregulation of MASTL is frequently observed in a variety of malignancies, including breast, gastric, and colon cancers, and often correlates with increased chromosomal instability, tumor progression, poor patient survival, and resistance to therapy.

This technical guide provides an in-depth exploration of the oncogenic functions of MASTL, detailing its core signaling pathways, summarizing key quantitative data, and providing comprehensive experimental protocols to facilitate further research in this promising area of cancer biology and drug development.

## Core Signaling Pathways Involving MASTL

MASTL exerts its primary oncogenic functions through the canonical MASTL-ENSA-PP2A pathway, which is central to the control of mitosis. However, recent studies have unveiled significant crosstalk with other critical oncogenic signaling cascades, including the AKT/mTOR and Wnt/ $\beta$ -catenin pathways.

## The Canonical MASTL-ENSA-PP2A Mitotic Pathway

During mitosis, the phosphorylation of a multitude of proteins by Cyclin-dependent kinase 1 (CDK1) is essential for mitotic entry and progression. The tumor suppressor protein phosphatase 2A (PP2A) complex, specifically the B55 subunit-containing holoenzyme (PP2A-B55), counteracts CDK1 activity by dephosphorylating its substrates. To maintain a robust mitotic state, PP2A-B55 activity must be suppressed. This is where MASTL plays a pivotal role.

Activated by CDK1, MASTL phosphorylates its key substrates,  $\alpha$ -endosulfine (ENSA) and cAMP-regulated phosphoprotein 19 (ARPP19). Upon phosphorylation, ENSA and ARPP19 become potent inhibitors of PP2A-B55. This inhibition prevents the premature dephosphorylation of CDK1 substrates, thereby ensuring the stability of the mitotic state. In cancer, overexpression of MASTL leads to excessive inhibition of PP2A-B55, which can result in mitotic errors, chromosomal instability, and aneuploidy – hallmarks of cancer.

**Caption:** The canonical MASTL-ENSA-PP2A signaling pathway in mitosis.

## Crosstalk with AKT/mTOR Signaling

The PI3K/AKT/mTOR pathway is a central regulator of cell growth, proliferation, and survival. Emerging evidence indicates that MASTL can modulate this pathway. Overexpression of MASTL has been associated with increased phosphorylation of AKT. One proposed mechanism involves MASTL-mediated activation of Glycogen Synthase Kinase 3 (GSK3), which in turn phosphorylates and promotes the degradation of the PH domain leucine-rich repeat protein phosphatase (PHLPP), a negative regulator of AKT. The loss of PHLPP leads to sustained AKT activation. Furthermore, mTORC1 has been shown to directly phosphorylate and activate MASTL, creating a feedback loop that sustains mTORC1-dependent phosphorylation of its downstream targets by inhibiting PP2A/B55-mediated dephosphorylation.

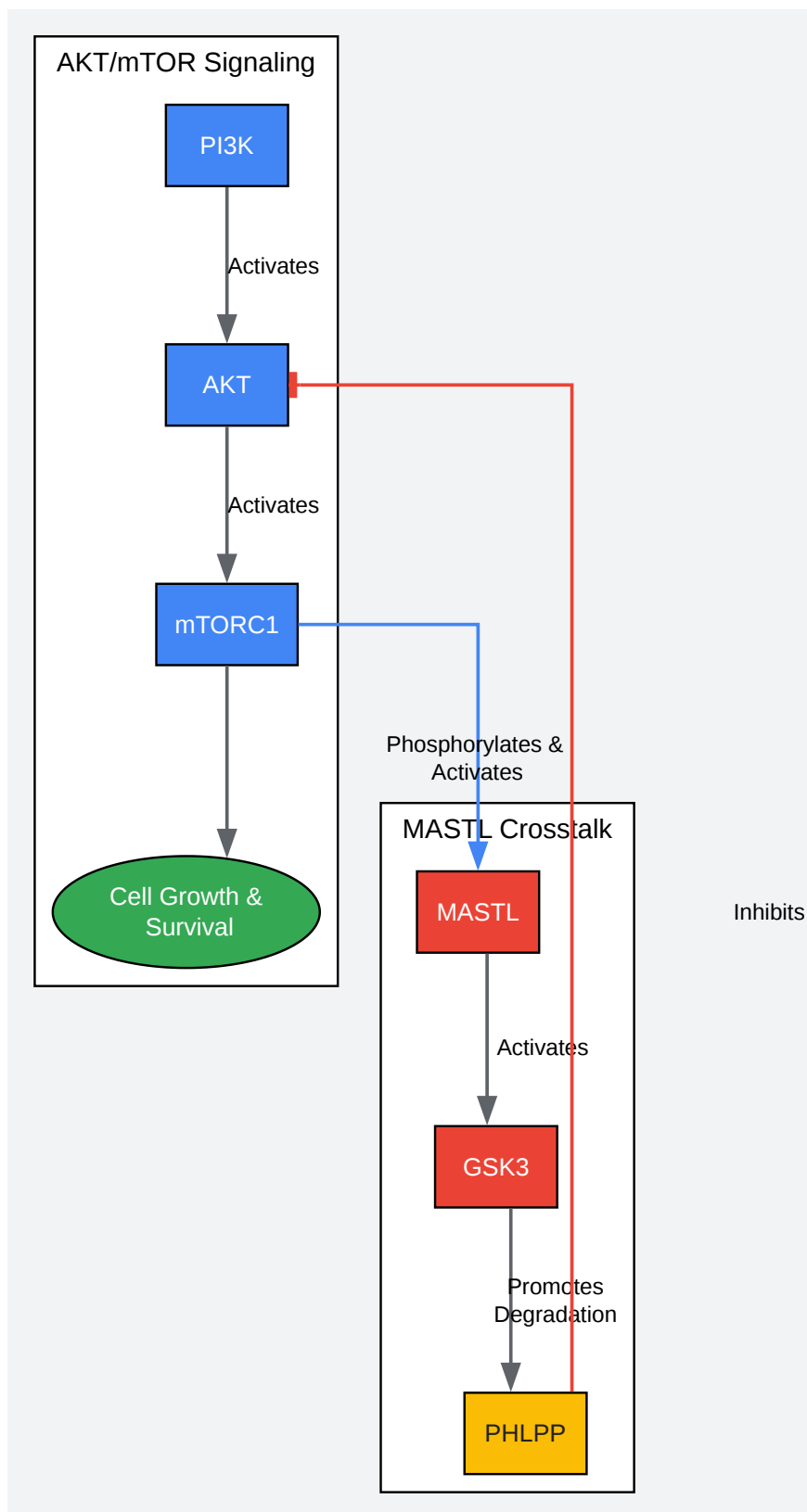

[Click to download full resolution via product page](#)

**Caption:** Crosstalk between MASTL and the AKT/mTOR signaling pathway.

## Crosstalk with Wnt/ $\beta$ -catenin Signaling

The Wnt/ $\beta$ -catenin pathway is crucial for embryonic development and its aberrant activation is a hallmark of many cancers, particularly colorectal cancer. MASTL has been shown to promote Wnt/ $\beta$ -catenin signaling by regulating the phosphorylation of GSK3 $\beta$  at Serine 9, which leads to its inactivation. Inactive GSK3 $\beta$  is unable to phosphorylate  $\beta$ -catenin, preventing its degradation and leading to its accumulation and translocation to the nucleus, where it activates the transcription of target genes involved in proliferation and cell fate.

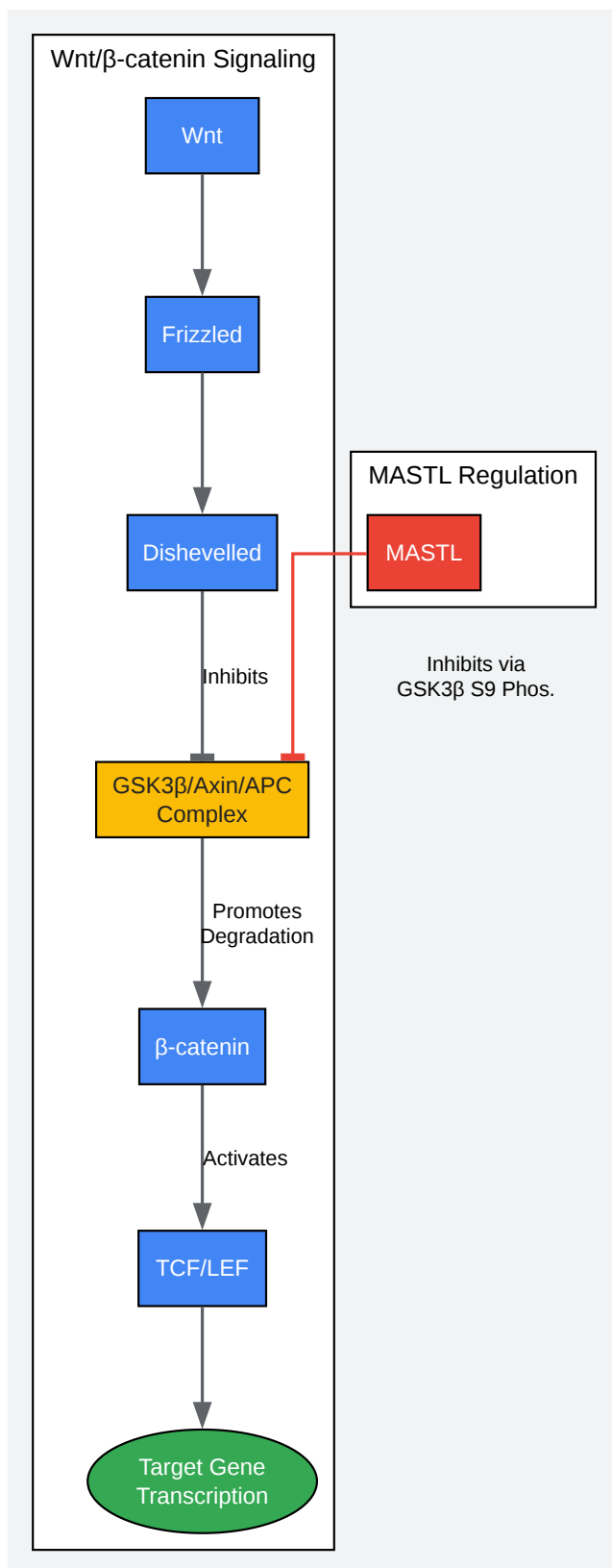

[Click to download full resolution via product page](#)

**Caption:** MASTL's role in the Wnt/β-catenin signaling pathway.

## Quantitative Data on MASTL in Cancer

The following tables summarize key quantitative data regarding MASTL expression, its association with clinical outcomes, and the effects of its inhibition.

### Table 1: MASTL Expression in Cancer

Cancer Type	Tissue	Finding	Reference
Breast Cancer	Carcinomas vs. Normal	Significantly higher MASTL mRNA levels in carcinomas (n=76) compared to normal breast tissues (n=61).	
Breast Cancer	Tumor vs. Normal	MASTL protein expression is significantly higher in breast cancer tissues (n=55) compared to normal counterparts (n=24).	
Breast Cancer	Cell Lines	Higher MASTL protein and mRNA expression in tumorigenic breast cancer cell lines compared to non-tumorigenic lines.	
Gastric Cancer	Tumor vs. Normal	MASTL is upregulated in gastric cancer.	

### Table 2: Clinical Significance of MASTL Expression

Cancer Type	Patient Cohort	Finding	Hazard Ratio (HR) and 95% CI	p-value	Reference
Breast Cancer	473 patients	High MASTL expression correlates with poor overall survival.	-	<0.05	
ER+ Breast Cancer	Meta-analysis	High MASTL expression is associated with a higher risk of metastatic relapse.	1.43 (1.28-1.60)	<0.001	
ER+ Breast Cancer	Meta-analysis	High MASTL expression is associated with a higher risk of any event (relapse or death).	1.27 (1.18-1.37)	<0.001	
ER+ Breast Cancer	Meta-analysis	High MASTL expression predicts worse metastatic relapse-free survival.	1.74 (1.40-2.17)	<0.001	
ER+ Breast Cancer	Meta-analysis	High MASTL expression predicts worse any	1.42 (1.23-1.63)	<0.001	

event-free  
survival.

**Table 3: Efficacy of MASTL Inhibitors**

Inhibitor	Assay Type	Cell Line(s)	IC50 / EC50	Reference
MKI-1	In vitro kinase assay	-	9.9 $\mu$ M	
MKI-2	In vitro kinase assay	-	37.44 nM	
MKI-2	Cellular assay	Breast cancer cells	142.7 nM	
MKI-2	Cell viability assay	MCF7, BT549, MDA-MB468, 4T1	56-124 nM	
Flavopiridol (FLV)	In vitro kinase assay	-	EC50 = 82.1 nM	

## Detailed Experimental Protocols

This section provides detailed methodologies for key experiments used to investigate the oncogenic functions of MASTL.

## Experimental Workflow: Investigating MASTL Function

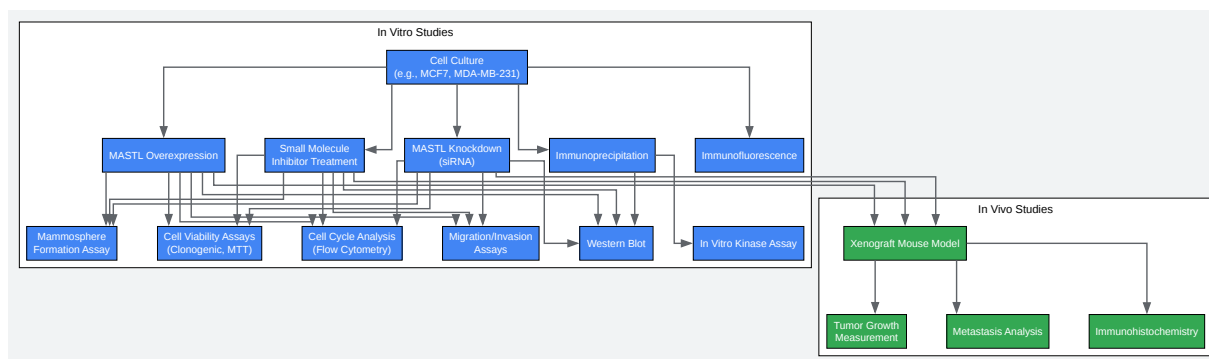

[Click to download full resolution via product page](#)

**Caption:** A general experimental workflow for investigating MASTL's oncogenic functions.

## MASTL In Vitro Kinase Assay (Radiometric)

This protocol describes a radiometric assay to measure the kinase activity of immunoprecipitated or recombinant MASTL.

Materials:

- Lysis Buffer: 50 mM Tris-HCl pH 7.5, 150 mM NaCl, 1 mM EDTA, 1% NP-40, protease and phosphatase inhibitor cocktails.
- IP Wash Buffer: Lysis buffer without protease and phosphatase inhibitors.

- Kinase Buffer: 10 mM Tris pH 7.5, 50 mM KCl, 10 mM MgCl<sub>2</sub>, 1 mM DTT.
- Anti-MASTL antibody for immunoprecipitation.
- Protein A/G agarose beads.
- Recombinant ARPP19 or ENSA substrate (5 μM).
- ATP solution (10 μM).
- [<sup>32</sup>P]ATP (5-10 μCi).
- 5X SDS-PAGE Sample Buffer.

#### Procedure:

- Immunoprecipitation of MASTL:
  - Prepare cell lysates using Lysis Buffer.
  - Pre-clear lysate with Protein A/G agarose beads for 1 hour at 4°C.
  - Incubate the pre-cleared lysate with anti-MASTL antibody overnight at 4°C.
  - Add Protein A/G agarose beads and incubate for 2-3 hours at 4°C to capture the antibody-MASTL complex.
  - Wash the beads three times with ice-cold IP Wash Buffer.
- Kinase Reaction:
  - Resuspend the beads in 20 μL of Kinase Assay Buffer.
  - Add 5 μM recombinant ARPP19 or ENSA substrate.
  - Add 10 μM ATP and 5-10 μCi [<sup>32</sup>P]ATP.
  - Incubate the reaction at 30°C for 30 minutes with gentle agitation.

- Detection:
  - Stop the reaction by adding 10  $\mu$ L of 5X SDS-PAGE Sample Buffer and boiling for 5 minutes.
  - Separate the proteins by SDS-PAGE.
  - Dry the gel and expose it to a phosphor screen or autoradiography film to detect the incorporation of  $^{32}$ P into the substrate.

## Clonogenic Assay

This assay assesses the ability of single cells to survive and proliferate to form colonies following treatment (e.g., with a MASTL inhibitor or radiation).

Materials:

- Complete cell culture medium.
- Trypsin-EDTA.
- Phosphate Buffered Saline (PBS).
- Fixation solution: 10% neutral buffered formalin.
- Staining solution: 0.01% (w/v) crystal violet in dH<sub>2</sub>O.
- 6-well or 10 cm culture dishes.

Procedure:

- \*\*Cell Se
- [To cite this document: BenchChem. \[Investigating the Oncogenic Functions of MASTL: A Technical Guide\]. BenchChem, \[2026\]. \[Online PDF\]. Available at: \[https://www.benchchem.com/product/b15622983/docs#investigating-the-oncogenic-functions-of-mastl-a-technical-guide\]](https://www.benchchem.com/product/b15622983/docs#investigating-the-oncogenic-functions-of-mastl-a-technical-guide)

**Disclaimer & Data Validity:**

The information provided in this document is for Research Use Only (RUO) and is strictly not intended for diagnostic or therapeutic procedures. While BenchChem strives to provide accurate protocols, we make no warranties, express or implied, regarding the fitness of this product for every specific experimental setup.

**Technical Support:** The protocols provided are for reference purposes. Unsure if this reagent suits your experiment?

**Need Industrial/Bulk Grade?** [Request Custom Synthesis Quote](#)

## BenchChem

Our mission is to be the trusted global source of essential and advanced chemicals, empowering scientists and researchers to drive progress in science and industry.

### Contact

Address: 3281 E Guasti Rd  
Ontario, CA 91761, United States  
Phone: (601) 213-4426  
Email: [info@benchchem.com](mailto:info@benchchem.com)

[Contact our Ph.D. Support Team for a compatibility check](#)