

Assessing the Specificity of ML406 for M. tb BioA: A Comparative Guide

Author: BenchChem Technical Support Team. **Date:** April 2026

Compound of Interest

Compound Name: ML406
CAS No.: 774589-47-8
Cat. No.: B15622952

[Get Quote](#)

For Researchers, Scientists, and Drug Development Professionals

The discovery of novel anti-tubercular agents with specific mechanisms of action is paramount in the fight against drug-resistant Mycobacterium tuberculosis (M. tb). One promising target is 7,8-diaminopelargonic acid (DAPA) synthase (BioA), a pyridoxal 5'-phosphate (PLP)-dependent enzyme essential for the biotin biosynthesis pathway in M. tb. This guide provides a comparative assessment of the specificity of **ML406**, a potent inhibitor of M. tb BioA, against other known inhibitors, supported by experimental data and detailed protocols.

Performance Comparison of M. tb BioA Inhibitors

The following table summarizes the in vitro potency, whole-cell activity, and selectivity of **ML406** in comparison to other identified M. tb BioA inhibitors.

Compound	Target	IC50 (μM)	M. tb H37Rv MIC90 (μM)	Selectivity	Cytotoxicity (IC50, μM)
ML406	M. tb BioA	0.03[1]	3.2[1]	>100-fold vs. M. tb BioD; Inactive vs. Aspartate Transaminase (AST)[1]	>20 μM against HEK293, HepG2, A549[1]
CHM-1	M. tb BioA	0.44[1]	50 (in biotin-free media)[1]	Not Reported	Not Reported
Amiclenomycin	M. tb BioA	Not Reported	Not Reported	Specific for mycobacteria [2]	Not Reported
A35	M. tb BioA	88.16[3]	80[3]	Inactive vs. AST[3]	150 (CHO cells)
A36	M. tb BioA	28.94[3]	>200 (83% inhibition at 200 μg/mL)[3]	Inactive vs. AST[3]	Not Evaluated
A65	M. tb BioA	114.42[3]	20[3]	Inactive vs. AST[3]	50 (CHO cells)

Experimental Methodologies

Biochemical Assay for M. tb BioA Inhibition

The inhibitory activity of compounds against M. tb BioA is determined using a coupled fluorescent dethiobiotin displacement assay.[1]

Principle: This assay relies on a two-step enzymatic reaction. First, BioA catalyzes the conversion of 7-keto-8-aminopelargonic acid (KAPA) to DAPA. Subsequently, the enzyme BioD utilizes DAPA to synthesize dethiobiotin (DTB). The produced DTB displaces a fluorescently labeled DTB probe from streptavidin, resulting in an increase in fluorescence signal. Inhibition of BioA leads to a decrease in DTB production and thus, a lower fluorescence signal.

Protocol:

- Reactions are typically performed in a 1536-well plate format.
- The reaction mixture contains *M. tb* BioA, *M. tb* BioD, KAPA, S-adenosyl methionine (SAM), ATP, a fluorescent DTB probe, and streptavidin in a suitable buffer (e.g., 100 mM Bicine, pH 8.6).
- Test compounds are added to the wells at varying concentrations.
- The reaction is initiated by the addition of KAPA and incubated at room temperature.
- The fluorescence intensity is measured using a plate reader.
- IC50 values are calculated from the dose-response curves.

Whole-Cell Growth Inhibition Assay

The minimum inhibitory concentration (MIC) against *M. tb* is determined using a broth microdilution method.

Principle: This assay measures the ability of a compound to inhibit the growth of *M. tb* in a liquid culture medium.

Protocol:

- *M. tb* H37Rv is cultured in a suitable medium, such as Middlebrook 7H9 broth, with and without biotin supplementation.
- The assay is performed in 96-well plates, where serially diluted compounds are added to the wells.
- An inoculum of *M. tb* is added to each well.
- The plates are incubated at 37°C for a defined period (e.g., 7-14 days).
- Bacterial growth is assessed by measuring the optical density at 600 nm or by using a viability indicator dye like resazurin.

- The MIC is defined as the lowest concentration of the compound that inhibits 90% of bacterial growth (MIC90).

Selectivity and Cytotoxicity Assays

Counter-Screening against M. tb BioD: To assess selectivity against the coupled enzyme in the primary assay, a similar protocol is followed, but with DAPA as the substrate instead of KAPA, and in the absence of BioA.[1]

Counter-Screening against PLP-Dependent Enzymes: To evaluate specificity for BioA over other PLP-dependent enzymes, compounds are tested against a representative enzyme such as aspartate transaminase (AST). The activity of AST can be monitored by coupling the reaction to malate dehydrogenase and measuring the decrease in NADH absorbance at 340 nm.[1]

Mammalian Cell Cytotoxicity Assay: The cytotoxicity of the compounds is evaluated against various human cell lines (e.g., HEK293, HepG2, A549) using a commercially available assay kit, such as the CellTiter-Glo Luminescent Cell Viability Assay, which measures ATP levels as an indicator of cell viability.[1]

Specificity Assessment of ML406

The specificity of an inhibitor is a critical parameter in drug development, as it minimizes the potential for off-target effects and associated toxicity. The experimental data presented provides a strong case for the high specificity of **ML406** for M. tb BioA.

On-Target Activity

The potent enzymatic inhibition of BioA by **ML406** (IC₅₀ = 30 nM) is coupled with effective whole-cell activity against M. tb (MIC₉₀ = 3.2 μM).[1] The on-target activity of **ML406** is further substantiated by the observation that its growth inhibitory effect is dependent on the expression level of BioA in conditional knockdown mutants of M. tb.

Selectivity Profile

ML406 demonstrates excellent selectivity. It is over 100-fold more selective for BioA than for the downstream enzyme in the biotin synthesis pathway, BioD.[1] Furthermore, **ML406** shows no inhibitory activity against the functionally related PLP-dependent enzyme, aspartate

transaminase, indicating a high degree of specificity for its intended target.[1] The lack of a human homolog for BioA further enhances the potential therapeutic window for inhibitors targeting this enzyme.

Comparison with Other Inhibitors

In comparison to other identified BioA inhibitors, **ML406** exhibits significantly greater potency at the enzymatic level. For instance, its IC50 is several orders of magnitude lower than that of compounds A35, A36, and A65.[3] While amiclennomycin is a known natural product inhibitor of BioA, its clinical development has been hampered by instability.[2]

Cytotoxicity

ML406 displays low cytotoxicity against a panel of human cell lines, with IC50 values greater than 20 μ M.[1] This favorable cytotoxicity profile, combined with its high potency and specificity, results in a promising therapeutic index.

Signaling Pathways and Experimental Workflows

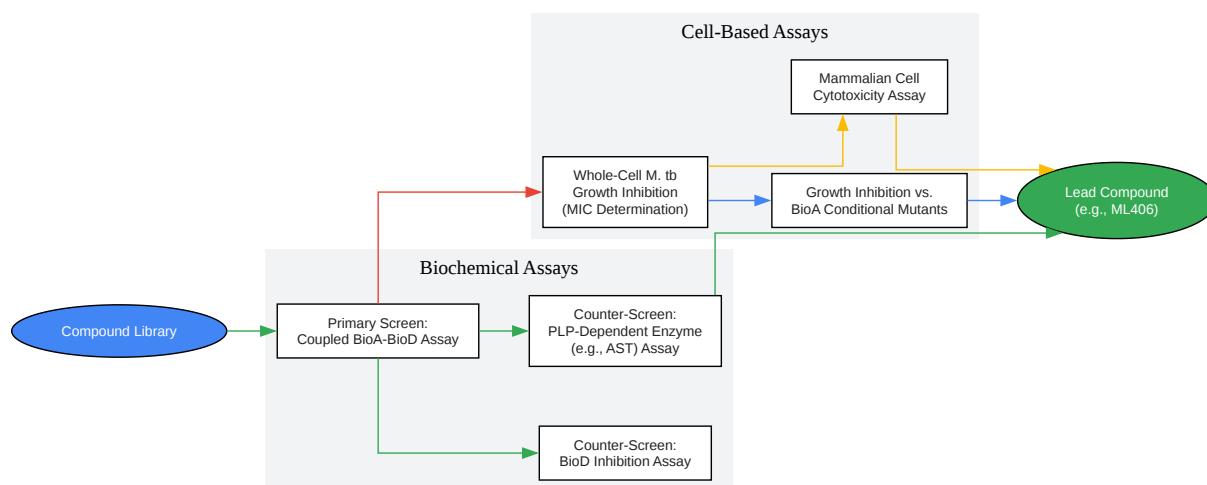

[Click to download full resolution via product page](#)

Caption: Workflow for identifying and characterizing specific *M. tb* BioA inhibitors.

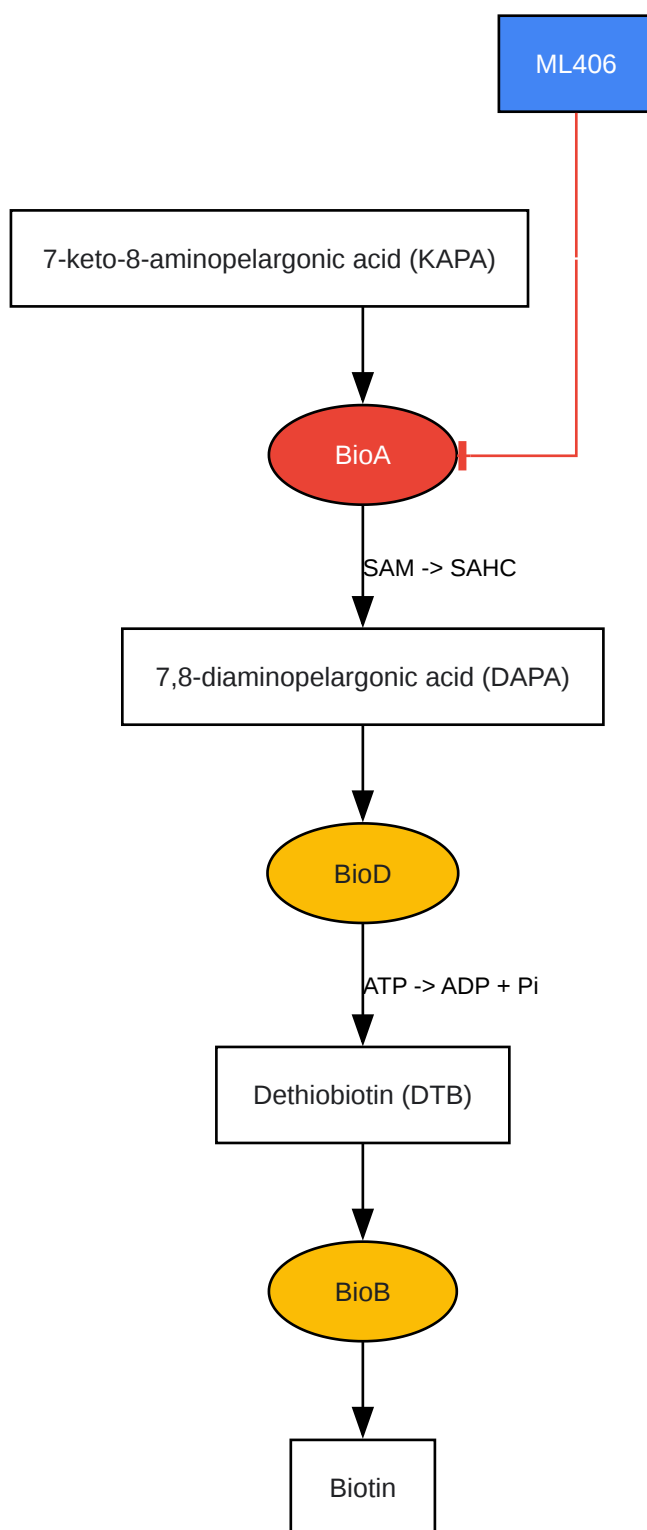

[Click to download full resolution via product page](#)

Caption: The *M. tb* biotin biosynthesis pathway and the inhibitory action of **ML406**.

Need Custom Synthesis?

BenchChem offers custom synthesis for rare earth carbides and specific isotopic labeling.

Email: info@benchchem.com or [Request Quote Online](#).

References

- 1. Discovery of small molecule probe that shows anti-tubercular activity via Mtb bioA (DAPA synthase) enzyme inhibition - Probe Reports from the NIH Molecular Libraries Program - NCBI Bookshelf [[ncbi.nlm.nih.gov](https://pubmed.ncbi.nlm.nih.gov/)]
- 2. [biorxiv.org](https://www.biorxiv.org/) [[biorxiv.org](https://www.biorxiv.org/)]
- 3. Identification of Mycobacterium tuberculosis BioA inhibitors by using structure-based virtual screening - PMC [[pmc.ncbi.nlm.nih.gov](https://pubmed.ncbi.nlm.nih.gov/)]
- To cite this document: BenchChem. [Assessing the Specificity of ML406 for M. tb BioA: A Comparative Guide]. BenchChem, [2026]. [Online PDF]. Available at: [<https://www.benchchem.com/product/b15622952/docs#assessing-the-specificity-of-ml406-for-m-tb-bioa-a-comparative-guide>]

Disclaimer & Data Validity:

The information provided in this document is for Research Use Only (RUO) and is strictly not intended for diagnostic or therapeutic procedures. While BenchChem strives to provide accurate protocols, we make no warranties, express or implied, regarding the fitness of this product for every specific experimental setup.

Technical Support: The protocols provided are for reference purposes. Unsure if this reagent suits your experiment?

Need Industrial/Bulk Grade? [Request Custom Synthesis Quote](#)

BenchChem

Our mission is to be the trusted global source of essential and advanced chemicals, empowering scientists and researchers to drive progress in science and industry.

Contact

Address: 3281 E Guasti Rd

Ontario, CA 91761, United States

Phone: (601) 213-4426

Email: info@benchchem.com

[Contact our Ph.D. Support Team for a compatibility check](#)