

# Application Notes and Protocols for Condensation Reactions with 3-Formyl Rifamycin

**Author:** BenchChem Technical Support Team. **Date:** April 2026

## Compound of Interest

Compound Name: 3-Formyl rifamycin

Cat. No.: B15622794

[Get Quote](#)

For Researchers, Scientists, and Drug Development Professionals

These application notes provide a comprehensive overview of condensation reactions involving **3-formyl rifamycin**, a key intermediate in the synthesis of potent antibiotic derivatives. The protocols detailed below are intended to guide researchers in the synthesis, purification, and characterization of novel rifamycin-based compounds with potential therapeutic applications.

## Introduction

Rifamycins are a class of macrocyclic antibiotics that function by inhibiting bacterial DNA-dependent RNA polymerase (RNAP), thereby blocking transcription.[1][2][3][4] **3-Formyl rifamycin** SV is a pivotal precursor for the semisynthesis of various rifamycin analogs, including the widely used anti-tuberculosis drug, rifampicin. The formyl group at the C-3 position of the naphthoquinone core is a reactive handle that readily undergoes condensation reactions with a variety of nucleophiles, particularly amines and hydrazines, to yield imines (Schiff bases) and hydrazones, respectively. These modifications at the C-3 position can significantly modulate the antibacterial spectrum, potency, and pharmacokinetic properties of the parent molecule.

## Condensation Reactions of 3-Formyl Rifamycin SV

The primary condensation reactions of **3-formyl rifamycin SV** involve the reaction of the aldehyde functionality with primary amines and hydrazines.

### Reaction with Primary Amines (Imine Formation)

The reaction of **3-formyl rifamycin SV** with primary amines leads to the formation of 3-(iminomethyl)rifamycin SV derivatives. These reactions are typically carried out in an inert organic solvent at room temperature or with gentle heating.

### Reaction with Hydrazines (Hydrazone Formation)

Condensation of **3-formyl rifamycin SV** with hydrazines yields 3-(hydrazonomethyl)rifamycin SV derivatives. This reaction is the basis for the synthesis of rifampicin, where 1-amino-4-methylpiperazine, a substituted hydrazine, is used. The reaction conditions are generally mild, occurring in solvents like tetrahydrofuran or ethanol at room temperature.<sup>[5][6]</sup>

## Quantitative Data Summary

The following tables summarize the reaction conditions, yields, and biological activities of various derivatives prepared from **3-formyl rifamycin SV**.

Table 1: Synthesis of **3-Formyl Rifamycin SV** Derivatives

Derivative Type	Reagent	Solvent	Temperature (°C)	Time	Yield (%)	Reference
Imine	1-Amino-4-cyclopentyl-piperazine	Tetrahydrofuran	Room Temperature	30 min	55	U.S. Patent CA109503 5A
Hydrazone	1-Amino-4-methylpiperazine	Tetrahydrofuran	Room Temperature	-	-	U.S. Patent US417432 0A[7]
Hydrazone	3-(3',4'-dimethylphenyl)-6-hydrazinopyridazine	Ethanol	45	5 min (crystallization start)	85	U.S. Patent US417943 9A[5]
Hydrazone	Isonicotinic acid hydrazide	Methanol	45-50	15 min	85	U.S. Patent US417943 9A[5]
Oxime	Hydroxylamine hydrochloride	Dichloromethane/Ethanol	Room Temperature	30 min	85	U.S. Patent US417943 9A[5]
Imine	Methylamine	-	-	-	-	[8]
Pyrimidopyrimycin	Ammonia	-	-	-	-	[8]

Table 2: Antibacterial Activity (MIC) of Rifamycin Derivatives

Compound	Organism	MIC (µg/mL)	Reference
Novel Rifamycins (NCEs)	Staphylococcus aureus (Rifampin-Susceptible)	0.002 - 0.03	[9][10]
ABI-0418	Staphylococcus aureus (Rifampin-Resistant)	2	[9]
ABI-0420	Staphylococcus aureus (Rifampin-Resistant)	2	[9]
ABI-0043	Staphylococcus aureus ATCC 29213	0.001	[11]
Rifampin	Staphylococcus aureus ATCC 29213	0.016	[11]
KRM1648, KRM1657, KRM1668, KRM1674, KRM2312	Mycobacterium tuberculosis (20 clinical isolates)	0.035 - 0.07 (MIC90)	[12]
Rifampicin	Mycobacterium tuberculosis (20 clinical isolates)	1.25 (MIC90)	[12]
KRM1648, KRM1657, KRM1668, KRM1674, KRM2312	Mycobacterium avium complex (20 clinical isolates)	0.07 - 0.3 (MIC90)	[12]
Rifabutin	Mycobacterium avium complex (20 clinical isolates)	5 (MIC90)	[12]
Rifampicin	Mycobacterium avium complex (20 clinical isolates)	40 - 80 (MIC90)	[12]
C-3-(N-alkyl-aryl)-aminoalkyl analogues	M. tuberculosis H37Rv and HN-878	Submicromolar to nanomolar	[13]

concentrations

---

C-3-(N-alkyl-aryl)- aminoalkyl analogues	M. tuberculosis RpoBS522L (Rifampin-Resistant)	Low micromolar concentrations	[13]
---	--	----------------------------------	------

---

## Experimental Protocols

### Protocol 1: General Procedure for the Synthesis of 3-(Iminomethyl)rifamycin SV Derivatives

This protocol describes a general method for the condensation of **3-formyl rifamycin SV** with primary amines.

Materials:

- **3-Formyl rifamycin SV**
- Primary amine of interest (e.g., benzylamine)
- Anhydrous tetrahydrofuran (THF)
- Anhydrous sodium sulfate
- Chloroform
- Dilute acetic acid
- Silica gel for column chromatography
- Solvents for chromatography (e.g., chloroform/methanol mixtures)

Procedure:

- Dissolve 1 molar equivalent of **3-formyl rifamycin SV** in anhydrous THF in a round-bottom flask equipped with a magnetic stirrer.
- Add 1.1 molar equivalents of the primary amine to the solution.

- Stir the reaction mixture at room temperature for 30 minutes to 2 hours. Monitor the reaction progress by thin-layer chromatography (TLC) until the starting material is consumed.
- Once the reaction is complete, dilute the mixture with chloroform.
- Wash the organic phase with dilute acetic acid to a pH of 5, followed by washing with water.
- Dry the organic phase over anhydrous sodium sulfate, filter, and concentrate under reduced pressure to obtain the crude product.
- Purify the crude product by column chromatography on silica gel using an appropriate solvent system (e.g., a gradient of methanol in chloroform) to yield the pure 3-(iminomethyl)rifamycin SV derivative.
- Characterize the final product by spectroscopic methods ( $^1\text{H}$  NMR,  $^{13}\text{C}$  NMR, MS).

## Protocol 2: Synthesis of Rifampicin (A 3-(Hydrazonomethyl)rifamycin SV Derivative)

This protocol outlines the synthesis of rifampicin from **3-formyl rifamycin SV** and 1-amino-4-methylpiperazine.

Materials:

- **3-Formyl rifamycin SV**
- 1-Amino-4-methylpiperazine
- Anhydrous tetrahydrofuran (THF)
- Ethanol
- Water

Procedure:

- Dissolve 1 molar equivalent of **3-formyl rifamycin SV** in anhydrous THF in a round-bottom flask.

- In a separate flask, prepare a solution of 1.1 molar equivalents of 1-amino-4-methylpiperazine in THF.
- Add the solution of 1-amino-4-methylpiperazine to the **3-formyl rifamycin SV** solution with stirring at room temperature.
- Stir the reaction mixture for 1-2 hours. Monitor the reaction by TLC for the disappearance of the starting aldehyde.
- Upon completion, concentrate the reaction mixture under reduced pressure.
- Recrystallize the resulting solid from a suitable solvent system, such as ethanol-water, to obtain pure rifampicin.
- Dry the crystalline product under vacuum.
- Confirm the identity and purity of the product using spectroscopic techniques and melting point determination.

### Protocol 3: Purification by Column Chromatography

Purification of rifamycin derivatives is crucial to remove unreacted starting materials and byproducts.

Materials:

- Crude rifamycin derivative
- Silica gel (60-120 mesh)
- Glass chromatography column
- Eluent (e.g., chloroform/methanol or ethyl acetate/hexane mixtures)
- Collection tubes

Procedure:

- Prepare a slurry of silica gel in the initial eluent solvent and pack it into the chromatography column.
- Dissolve the crude product in a minimal amount of the eluent or a suitable solvent and load it onto the top of the silica gel column.
- Elute the column with the chosen solvent system, gradually increasing the polarity if a gradient elution is required.
- Collect fractions and monitor the separation by TLC.
- Combine the fractions containing the pure product.
- Evaporate the solvent from the combined fractions under reduced pressure to obtain the purified rifamycin derivative.

## Visualizations

### Signaling Pathway Diagram

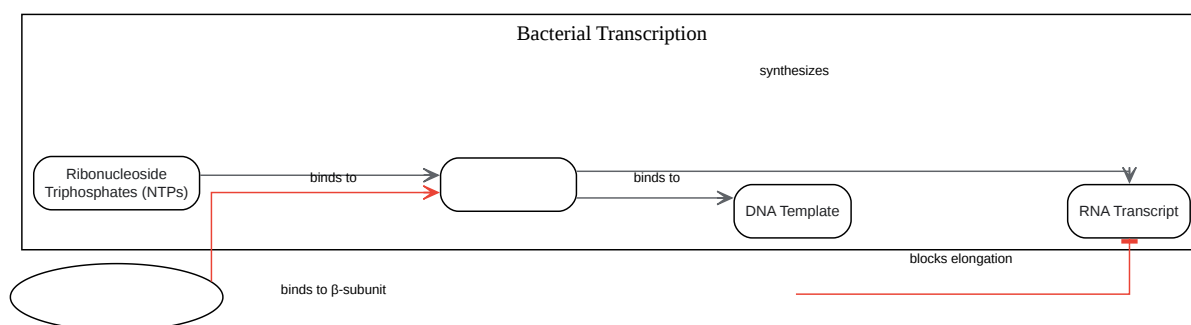

[Click to download full resolution via product page](#)

Caption: Inhibition of bacterial RNA polymerase by **3-formyl rifamycin** derivatives.

## Experimental Workflow Diagram

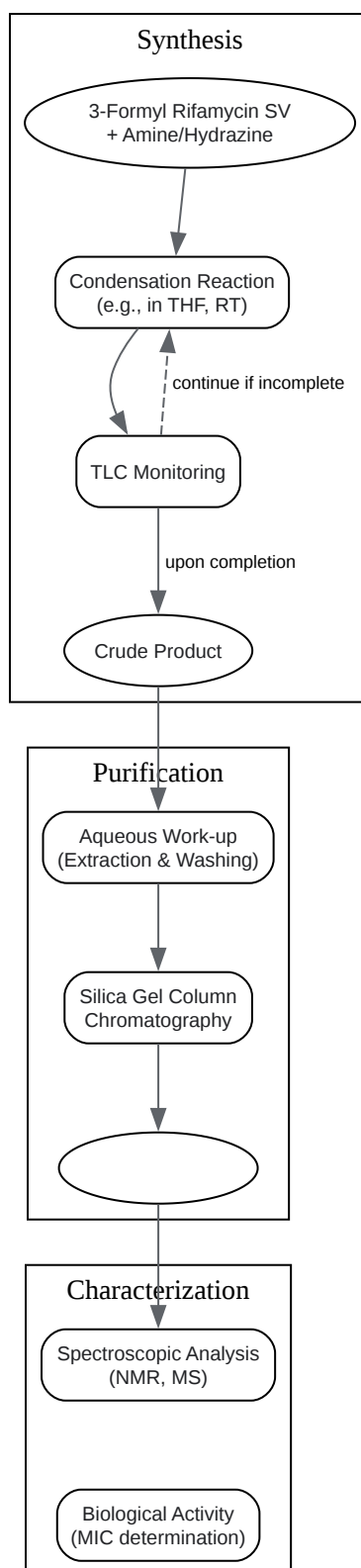

[Click to download full resolution via product page](#)

Caption: General workflow for the synthesis and evaluation of **3-formyl rifamycin** derivatives.

### Need Custom Synthesis?

BenchChem offers custom synthesis for rare earth carbides and specific isotopic labeling.

Email: [info@benchchem.com](mailto:info@benchchem.com) or [Request Quote Online](#).

## References

- 1. Structural basis for rifamycin resistance of bacterial RNA polymerase by the three most clinically important RpoB mutations found in Mycobacterium tuberculosis - PMC [[pmc.ncbi.nlm.nih.gov](http://pmc.ncbi.nlm.nih.gov)]
- 2. [journals.asm.org](http://journals.asm.org) [[journals.asm.org](http://journals.asm.org)]
- 3. Structural mechanism for rifampicin inhibition of bacterial rna polymerase - PubMed [[pubmed.ncbi.nlm.nih.gov](http://pubmed.ncbi.nlm.nih.gov)]
- 4. What is the mechanism of Rifampin? [[synapse.patsnap.com](http://synapse.patsnap.com)]
- 5. US4179439A - Rifamycins and method for their preparation - Google Patents [[patents.google.com](http://patents.google.com)]
- 6. CA1095035A - Process for the production of rifamycins - Google Patents [[patents.google.com](http://patents.google.com)]
- 7. US4174320A - Process for the preparation of rifampicin - Google Patents [[patents.google.com](http://patents.google.com)]
- 8. [researchgate.net](http://researchgate.net) [[researchgate.net](http://researchgate.net)]
- 9. Efficacy of Novel Rifamycin Derivatives against Rifamycin-Sensitive and -Resistant Staphylococcus aureus Isolates in Murine Models of Infection - PMC [[pmc.ncbi.nlm.nih.gov](http://pmc.ncbi.nlm.nih.gov)]
- 10. Efficacy of novel rifamycin derivatives against rifamycin-sensitive and -resistant Staphylococcus aureus isolates in murine models of infection - PubMed [[pubmed.ncbi.nlm.nih.gov](http://pubmed.ncbi.nlm.nih.gov)]
- 11. Efficacy of a Novel Rifamycin Derivative, ABI-0043, against Staphylococcus aureus in an Experimental Model of Foreign-Body Infection - PMC [[pmc.ncbi.nlm.nih.gov](http://pmc.ncbi.nlm.nih.gov)]
- 12. [In vitro activities of new rifamycin derivatives against Mycobacterium tuberculosis and M. avium complex] - PubMed [[pubmed.ncbi.nlm.nih.gov](http://pubmed.ncbi.nlm.nih.gov)]
- 13. Novel C-3-(N-alkyl-aryl)-aminomethyl rifamycin SV derivatives exhibit activity against rifampicin-resistant Mycobacterium tuberculosis RpoBS522L strain and display a different

[binding mode at the RNAP  \$\beta\$ -subunit site compared to rifampicin - PubMed](#)  
[\[pubmed.ncbi.nlm.nih.gov\]](https://pubmed.ncbi.nlm.nih.gov)

- To cite this document: BenchChem. [Application Notes and Protocols for Condensation Reactions with 3-Formyl Rifamycin]. BenchChem, [2026]. [Online PDF]. Available at: [\[https://www.benchchem.com/product/b15622794/docs#application-notes-and-protocols-for-condensation-reactions-with-3-formyl-rifamycin\]](https://www.benchchem.com/product/b15622794/docs#application-notes-and-protocols-for-condensation-reactions-with-3-formyl-rifamycin)

---

### Disclaimer & Data Validity:

The information provided in this document is for Research Use Only (RUO) and is strictly not intended for diagnostic or therapeutic procedures. While BenchChem strives to provide accurate protocols, we make no warranties, express or implied, regarding the fitness of this product for every specific experimental setup.

**Technical Support:** The protocols provided are for reference purposes. Unsure if this reagent suits your experiment?

**Need Industrial/Bulk Grade?** [Request Custom Synthesis Quote](#)

## BenchChem

Our mission is to be the trusted global source of essential and advanced chemicals, empowering scientists and researchers to drive progress in science and industry.

### Contact

Address: 3281 E Guasti Rd  
Ontario, CA 91761, United States  
Phone: (601) 213-4426  
Email: [info@benchchem.com](mailto:info@benchchem.com)

[Contact our Ph.D. Support Team for a compatibility check](#)