

Application Notes and Protocols for Arylomycin B1 Antibacterial Susceptibility Testing

Author: BenchChem Technical Support Team. **Date:** April 2026

Compound of Interest

Compound Name: Arylomycin B1

Cat. No.: B15622840

[Get Quote](#)

For Researchers, Scientists, and Drug Development Professionals

These application notes provide detailed protocols for determining the antibacterial susceptibility of **Arylomycin B1**, a member of a novel class of antibiotics that inhibit type I signal peptidase (SPase).^{[1][2][3]} The following sections detail the mechanism of action, quantitative susceptibility data, and standardized experimental protocols for accurate and reproducible testing.

Mechanism of Action

Arylomycins exert their antibacterial effect by targeting and inhibiting bacterial type I signal peptidase (SPase), an essential enzyme.^{[3][4]} SPase is a membrane-bound protease responsible for cleaving the N-terminal signal peptides from preproteins that are translocated across the cytoplasmic membrane.^{[1][5]} Inhibition of SPase disrupts the general secretory pathway, leading to a mislocalization of proteins and ultimately impacting bacterial viability.^{[1][2]} The activity of arylomycins can be either bacteriostatic or bactericidal depending on the bacterial species and growth conditions.^{[1][6]}

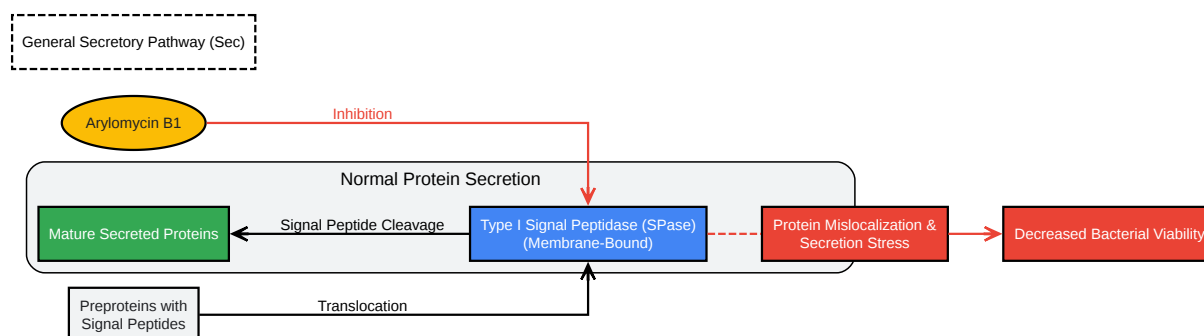

[Click to download full resolution via product page](#)

Figure 1: Mechanism of action of **Arylomycin B1**.

Quantitative Susceptibility Data

The antibacterial activity of arylomycins is often quantified by the Minimum Inhibitory Concentration (MIC), which is the lowest concentration of an antibiotic that prevents visible growth of a bacterium.[7] The following table summarizes MIC values for Arylomycin C16 (a closely related and well-studied analog) against various wild-type and genetically sensitized bacterial strains. Natural resistance in some key pathogens is linked to a specific proline residue in the SPase target.[8][9]

Bacterial Strain	Genotype	Arylomycin C16 MIC ($\mu\text{g/mL}$)	Reference
Staphylococcus epidermidis RP62A	Wild-Type	0.25	[9]
Staphylococcus aureus PAS8001	SPase P29S mutant	0.25	[8]
Staphylococcus aureus NCTC 8325	Wild-Type	>128	[8]
Escherichia coli PAS0260	SPase P84L mutant	4	[8]
Pseudomonas aeruginosa PAS2006	SPase P84L mutant	8	[8]
Helicobacter pylori	Wild-Type (SPase Ala29)	4	[9]
Chlamydia trachomatis	Wild-Type (SPase Leu29)	6	[9]

Experimental Protocols

Standardized susceptibility testing methods are crucial for reliable and comparable results. The Clinical and Laboratory Standards Institute (CLSI) provides guidelines for these tests.[10][11][12]

Broth Microdilution for MIC Determination

This method determines the MIC of **Arylomycin B1** in a liquid growth medium.[8][9]

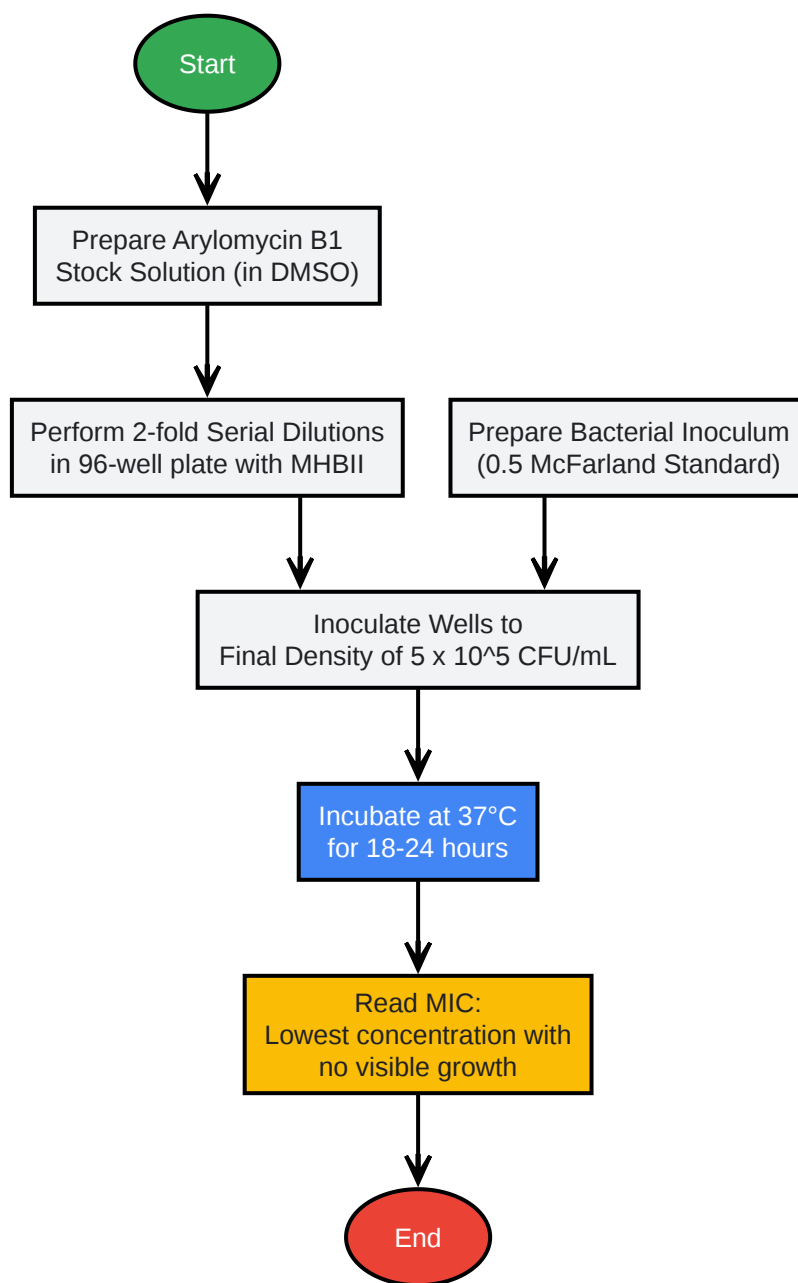

[Click to download full resolution via product page](#)

Figure 2: Broth microdilution workflow.

Materials:

- **Arylomycin B1**
- Dimethyl sulfoxide (DMSO)[1]

- Cation-adjusted Mueller-Hinton II Broth (MHBII)[1][6]
- Sterile 96-well flat-bottom plates[8]
- Bacterial culture in the logarithmic growth phase
- 0.5 McFarland turbidity standard[13]
- Spectrophotometer (optional, for inoculum standardization)
- Incubator (37°C)[1]

Protocol:

- Preparation of **Arylomycin B1** Stock Solution: Dissolve **Arylomycin B1** in DMSO to a final concentration of 10 mg/mL.[1]
- Serial Dilutions: a. Add 100 μ L of MHBII to each well of a 96-well plate.[1] b. Add a specific volume of the **Arylomycin B1** stock solution to the first well to achieve the starting concentration, and perform 2-fold serial dilutions across the plate.[1]
- Inoculum Preparation: a. Select isolated colonies from an 18-24 hour agar plate.[14] b. Suspend the colonies in MHBII. c. Adjust the turbidity of the suspension to match the 0.5 McFarland standard (approximately $1-2 \times 10^8$ CFU/mL).[13] d. Dilute this suspension to achieve a final inoculum density of 5×10^5 CFU/mL in the wells.[1]
- Inoculation: Inoculate each well (containing 100 μ L of diluted **Arylomycin B1**) with the prepared bacterial suspension to the final density.[1]
- Incubation: Seal the plates and incubate at 37°C for 18-24 hours.[1][8]
- MIC Determination: The MIC is the lowest concentration of **Arylomycin B1** at which no visible bacterial growth is observed.[1]

Disk Diffusion Susceptibility Testing

This method provides a qualitative or semi-quantitative assessment of susceptibility by measuring the zone of growth inhibition around a disk impregnated with **Arylomycin B1**. [13]

[15]

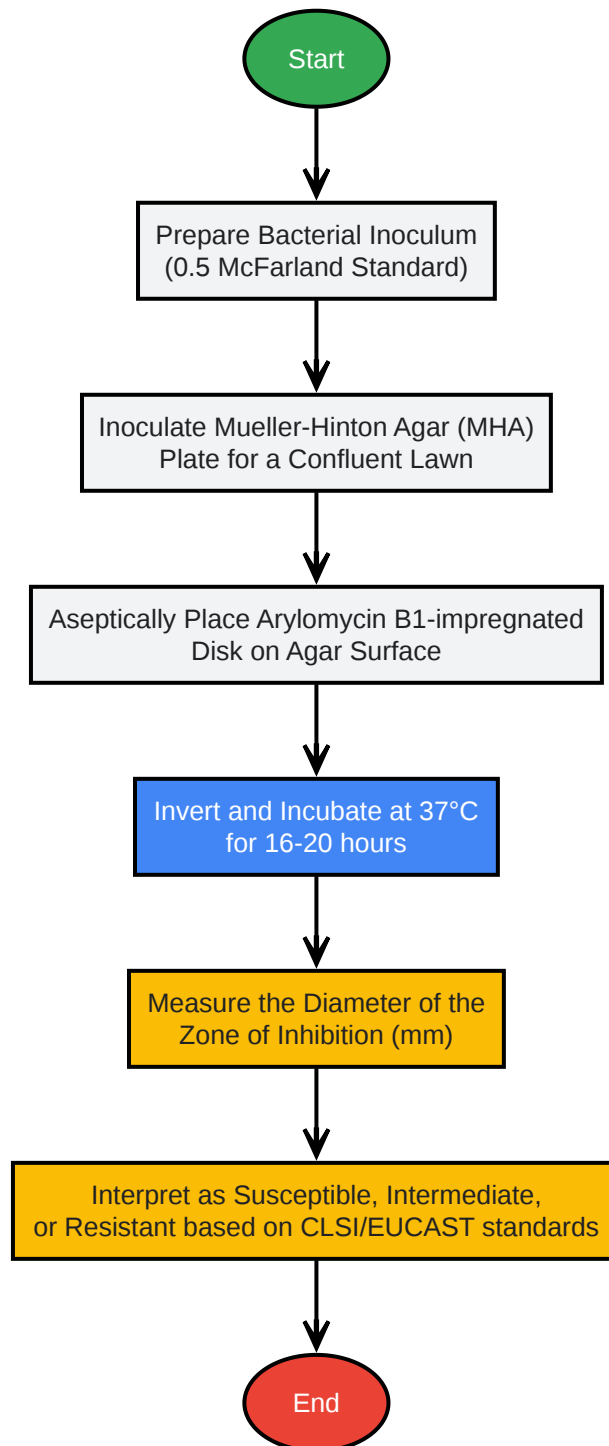

[Click to download full resolution via product page](#)

Figure 3: Disk diffusion workflow.

Materials:

- **Arylomycin B1**-impregnated paper disks
- Mueller-Hinton Agar (MHA) plates (4 mm depth)[13][16]
- Sterile cotton swabs[14]
- Bacterial culture
- 0.5 McFarland turbidity standard[13]
- Forceps or disk dispenser[14]
- Ruler or caliper[14]
- Incubator (37°C)[16]

Protocol:

- Inoculum Preparation: Prepare a bacterial suspension equivalent to a 0.5 McFarland standard as described in the broth microdilution protocol.[13]
- Plate Inoculation: a. Dip a sterile cotton swab into the adjusted bacterial suspension, removing excess fluid by pressing it against the inside of the tube.[14] b. Streak the swab evenly across the entire surface of the MHA plate in three directions, rotating the plate approximately 60 degrees each time to ensure a confluent lawn of growth.[14][17] c. Allow the plate to dry for 3-5 minutes, but no more than 15 minutes.[18]
- Disk Placement: Aseptically apply the **Arylomycin B1**-impregnated disk to the center of the inoculated agar surface.[14] Gently press the disk to ensure complete contact with the agar. [14]
- Incubation: Invert the plates and incubate at 37°C for 16-20 hours.[16]
- Measurement and Interpretation: a. After incubation, measure the diameter of the zone of complete growth inhibition in millimeters (mm), including the disk.[16] b. Interpret the results

as "Susceptible," "Intermediate," or "Resistant" by comparing the zone diameter to established breakpoints from standards organizations like CLSI or EUCAST.[16][19]

Quality Control

For all susceptibility testing, it is imperative to include quality control (QC) strains with known susceptibility profiles as recommended by CLSI.[20] This ensures the accuracy and reproducibility of the testing procedure. QC should be performed for both the commercial test method and the reference method.[20]

Need Custom Synthesis?

BenchChem offers custom synthesis for rare earth carbides and specific isotopic labeling.

Email: info@benchchem.com or [Request Quote Online](#).

References

- [1. Mechanism of Action of the Arylomycin Antibiotics and Effects of Signal Peptidase I Inhibition - PMC \[pmc.ncbi.nlm.nih.gov\]](#)
- [2. Mechanism of action of the arylomycin antibiotics and effects of signal peptidase I inhibition - PubMed \[pubmed.ncbi.nlm.nih.gov\]](#)
- [3. Arylomycin - Wikipedia \[en.wikipedia.org\]](#)
- [4. Antibiotic Breakthrough: The Emergence of Optimized Arylomycins as Effective Gram-Negative Treatments – Polyamyna \[polyamyna.ca\]](#)
- [5. The inhibition of type I bacterial signal peptidase: biological consequences and therapeutic potential - PMC \[pmc.ncbi.nlm.nih.gov\]](#)
- [6. researchgate.net \[researchgate.net\]](#)
- [7. idexx.dk \[idexx.dk\]](#)
- [8. Initial efforts toward the optimization of arylomycins for antibiotic activity - PMC \[pmc.ncbi.nlm.nih.gov\]](#)
- [9. Broad Spectrum Antibiotic Activity of the Arylomycin Natural Products is Masked by Natural Target Mutations - PMC \[pmc.ncbi.nlm.nih.gov\]](#)
- [10. Antimicrobial Susceptibility Testing | Area of Focus | CLSI \[clsi.org\]](#)
- [11. iaclid.com \[iaclid.com\]](#)

- [12. M100 | Performance Standards for Antimicrobial Susceptibility Testing \[clsi.org\]](#)
- [13. Disk Diffusion Method for Antibiotic Susceptibility Test - Creative Biolabs \[live-biotherapeutic.creative-biolabs.com\]](#)
- [14. hardydiagnostics.com \[hardydiagnostics.com\]](#)
- [15. mdpi.com \[mdpi.com\]](#)
- [16. fpharm.uniba.sk \[fpharm.uniba.sk\]](#)
- [17. google.com \[google.com\]](#)
- [18. asm.org \[asm.org\]](#)
- [19. commerce.bio-rad.com \[commerce.bio-rad.com\]](#)
- [20. journals.asm.org \[journals.asm.org\]](#)
- To cite this document: BenchChem. [Application Notes and Protocols for Arylomycin B1 Antibacterial Susceptibility Testing]. BenchChem, [2026]. [Online PDF]. Available at: [<https://www.benchchem.com/product/b15622840/docs#application-notes-and-protocols-for-arylomycin-b1-antibacterial-susceptibility-testing>]

Disclaimer & Data Validity:

The information provided in this document is for Research Use Only (RUO) and is strictly not intended for diagnostic or therapeutic procedures. While BenchChem strives to provide accurate protocols, we make no warranties, express or implied, regarding the fitness of this product for every specific experimental setup.

Technical Support: The protocols provided are for reference purposes. Unsure if this reagent suits your experiment?

Need Industrial/Bulk Grade? [Request Custom Synthesis Quote](#)

BenchChem

Our mission is to be the trusted global source of essential and advanced chemicals, empowering scientists and researchers to drive progress in science and industry.

Contact

Address: 3281 E Guasti Rd

Ontario, CA 91761, United States

Phone: (601) 213-4426

Email: info@benchchem.com

[Contact our Ph.D. Support Team for a compatibility check](#)