

Validating BTK Degradation: A Comparative Guide to PROTAC Performance and Control

Author: BenchChem Technical Support Team. **Date:** April 2026

Compound of Interest

Compound Name: *BTK ligand 12*

Cat. No.: *B15621658*

[Get Quote](#)

For Researchers, Scientists, and Drug Development Professionals

The targeted degradation of Bruton's tyrosine kinase (BTK) using Proteolysis Targeting Chimeras (PROTACs) represents a promising therapeutic strategy in oncology and immunology. Unlike traditional inhibitors, BTK PROTACs mediate the destruction of the entire protein, potentially offering a more profound and durable therapeutic effect and a means to overcome resistance. Rigorous validation of on-target protein degradation is crucial. This guide provides a comparative framework for assessing the performance of BTK degraders, emphasizing the critical role of appropriate negative controls for robust experimental validation.

The Principle of PROTAC-mediated BTK Degradation

BTK PROTACs are heterobifunctional molecules composed of three key components: a ligand that binds to BTK, a ligand that recruits an E3 ubiquitin ligase (commonly Cereblon [CRBN] or Von Hippel-Lindau [VHL]), and a linker connecting the two. This tripartite complex formation brings BTK in close proximity to the E3 ligase, leading to the ubiquitination of BTK and its subsequent degradation by the proteasome.

To validate that the observed reduction in BTK levels is a direct result of this specific mechanism, it is essential to use a negative control that is structurally analogous to the active PROTAC but lacks a key functional element. A common and effective control strategy involves modifying the E3 ligase ligand to abolish its binding. For instance, a PROTAC utilizing a pomalidomide-based CRBN ligand can be controlled with a version where the glutarimide ring of pomalidomide is methylated, preventing its interaction with CRBN. This ensures that any observed effects are not due to off-target activities of the BTK-binding moiety or the linker.

Comparative Analysis of BTK Degradation

The efficacy of a BTK degrader is typically quantified by its DC50 (concentration at which 50% of the target protein is degraded) and Dmax (the maximum percentage of degradation). The following table summarizes representative data comparing the degradation potential of various BTK PROTACs with their respective inactive controls.

Compound ID	Target	E3 Ligase Ligand	DC50 (nM)	Dmax (%)	Negative Control	Control DC50 (nM)	Control Dmax (%)	Reference
MT-802	BTK	Pomalidomide (CRBN)	~9	>99	SJF-6625 (inactive CRBN ligand)	No degradation observed	0	[1]
DD-03-171	BTK	Thalidomide (CRBN)	5.1	>90	DD-03-033 (inactive CRBN ligand)	No degradation observed	0	[2]
RC-1	BTK	Pomalidomide (CRBN)	<10	>85	RC-Ctrl (BTK ligand only)	No degradation observed	0	[3]
Non-covalent PROTAC	BTK	IAP	~200	Significant	Covale nt PROTA C (did not degrad e BTK)	No degradation observed	0	[1]

Experimental Protocols

Accurate and reproducible quantification of BTK degradation is paramount. The following are detailed protocols for key experiments used to validate the activity of BTK PROTACs.

Western Blotting for BTK Degradation Quantification

This protocol allows for the visualization and quantification of the decrease in total BTK protein levels upon treatment with a BTK degrader.

a. Cell Culture and Treatment:

- Seed cells (e.g., Ramos, THP-1, or other relevant cell lines) at an appropriate density in 6-well plates.
- Allow cells to adhere or stabilize overnight.
- Treat cells with a serial dilution of the BTK PROTAC and the negative control for a specified time course (e.g., 4, 8, 16, 24 hours). Include a vehicle-only control (e.g., DMSO).

b. Cell Lysis:

- After treatment, harvest the cells and wash with ice-cold PBS.
- Lyse the cell pellet in RIPA buffer supplemented with protease and phosphatase inhibitors.
- Incubate on ice for 30 minutes, followed by centrifugation to pellet cell debris.
- Collect the supernatant containing the protein lysate.

c. Protein Quantification:

- Determine the protein concentration of each lysate using a BCA or Bradford assay to ensure equal loading.

d. SDS-PAGE and Western Blotting:

- Denature 20-40 μg of protein from each sample by boiling in Laemmli buffer.
- Separate the proteins by SDS-polyacrylamide gel electrophoresis.
- Transfer the separated proteins to a PVDF or nitrocellulose membrane.
- Block the membrane with 5% non-fat milk or BSA in TBST for 1 hour at room temperature.

- Incubate the membrane with a primary antibody against BTK (e.g., rabbit anti-BTK) overnight at 4°C.
- Incubate with a primary antibody against a loading control (e.g., β -actin, GAPDH) to normalize for protein loading.
- Wash the membrane with TBST and incubate with an HRP-conjugated secondary antibody for 1 hour at room temperature.
- Detect the signal using an enhanced chemiluminescence (ECL) substrate and an imaging system.

e. Data Analysis:

- Quantify the band intensities using densitometry software.
- Normalize the BTK band intensity to the corresponding loading control band intensity.
- Calculate the percentage of BTK degradation relative to the vehicle-treated control.
- Plot the percentage of degradation against the compound concentration to determine the DC50 value.

Co-Immunoprecipitation to Confirm BTK Ubiquitination

This protocol is used to demonstrate that the PROTAC induces the ubiquitination of BTK, a key step in the degradation process.

a. Cell Treatment and Lysis:

- Treat cells with the BTK PROTAC, negative control, and a proteasome inhibitor (e.g., MG132) for a shorter time period (e.g., 2-4 hours) to allow for the accumulation of ubiquitinated proteins.
- Lyse the cells in a non-denaturing lysis buffer containing a deubiquitinase inhibitor (e.g., PR-619).

b. Immunoprecipitation:

- Pre-clear the cell lysates with Protein A/G agarose beads.
- Incubate the lysates with an anti-BTK antibody overnight at 4°C to form immune complexes.
- Add Protein A/G agarose beads to capture the immune complexes.
- Wash the beads extensively to remove non-specific binding proteins.

c. Elution and Western Blotting:

- Elute the immunoprecipitated proteins from the beads by boiling in SDS-PAGE sample buffer.
- Perform Western blotting as described above.
- Probe the membrane with an anti-ubiquitin antibody to detect the polyubiquitin chains on BTK. A smear or ladder of high molecular weight bands will indicate ubiquitination.
- Probe a separate blot with an anti-BTK antibody to confirm the successful immunoprecipitation of BTK.

Visualizing the Molecular Pathways and Experimental Logic

To further clarify the underlying mechanisms and experimental design, the following diagrams are provided.

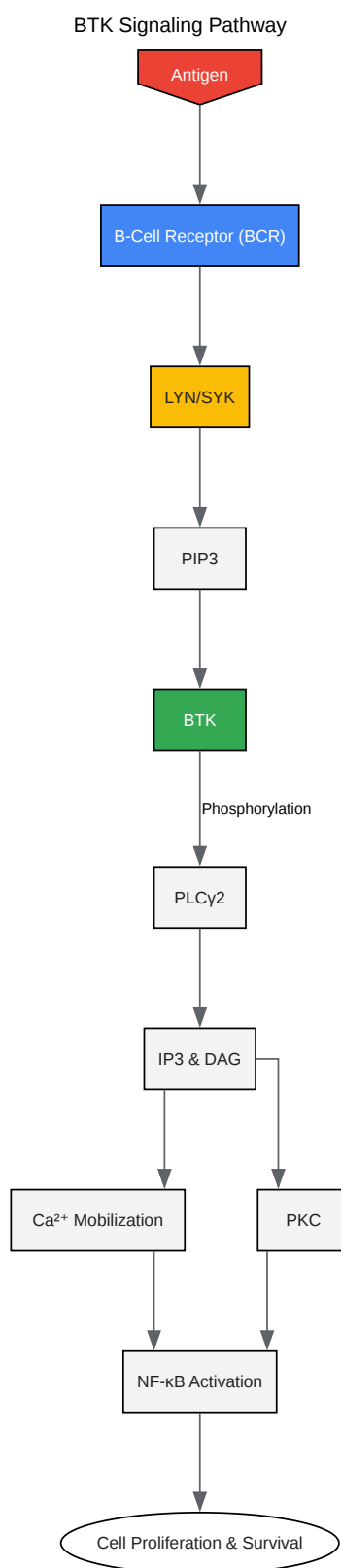

[Click to download full resolution via product page](#)

Caption: The B-Cell Receptor (BCR) signaling cascade, where BTK plays a pivotal role.

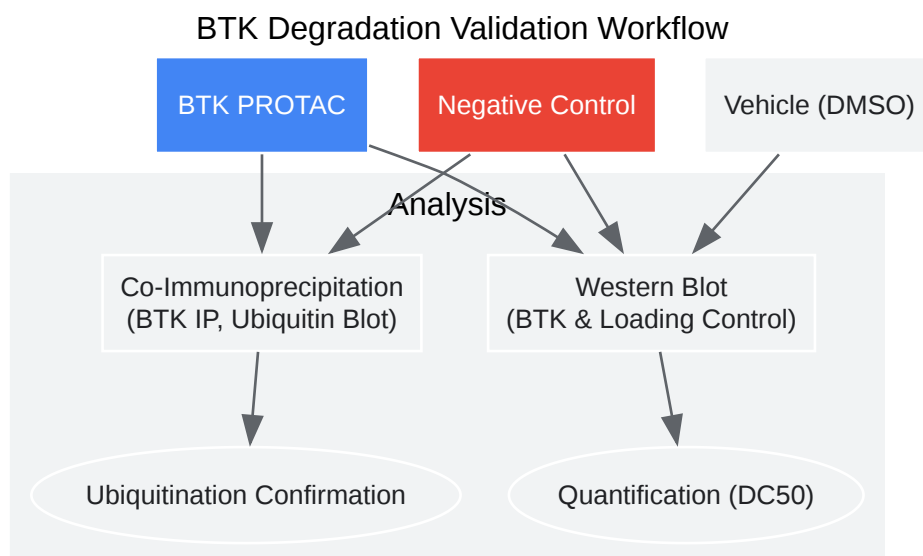

[Click to download full resolution via product page](#)

Caption: Experimental workflow for validating BTK degradation by a PROTAC.

Need Custom Synthesis?

BenchChem offers custom synthesis for rare earth carbides and specific isotopic labeling.

Email: info@benchchem.com or [Request Quote Online](#).

References

- 1. Development of PROTACs to address clinical limitations associated with BTK-targeted kinase inhibitors - PMC [[pmc.ncbi.nlm.nih.gov](https://pubmed.ncbi.nlm.nih.gov/)]
- 2. Bruton tyrosine kinase degradation as a therapeutic strategy for cancer - PMC [[pmc.ncbi.nlm.nih.gov](https://pubmed.ncbi.nlm.nih.gov/)]
- 3. Efficient Targeted Degradation via Reversible and Irreversible Covalent PROTACs - PMC [[pmc.ncbi.nlm.nih.gov](https://pubmed.ncbi.nlm.nih.gov/)]
- To cite this document: BenchChem. [Validating BTK Degradation: A Comparative Guide to PROTAC Performance and Control]. BenchChem, [2026]. [Online PDF]. Available at: [<https://www.benchchem.com/product/b15621658/docs#validating-btk-degradation-a-comparative-guide-to-protac-performance-and-control>]

Disclaimer & Data Validity:

The information provided in this document is for Research Use Only (RUO) and is strictly not intended for diagnostic or therapeutic procedures. While BenchChem strives to provide accurate protocols, we make no warranties, express or implied, regarding the fitness of this product for every specific experimental setup.

Technical Support: The protocols provided are for reference purposes. Unsure if this reagent suits your experiment?

Need Industrial/Bulk Grade? [Request Custom Synthesis Quote](#)

BenchChem

Our mission is to be the trusted global source of essential and advanced chemicals, empowering scientists and researchers to drive progress in science and industry.

Contact

Address: 3281 E Guasti Rd
Ontario, CA 91761, United States
Phone: (601) 213-4426
Email: info@benchchem.com

[Contact our Ph.D. Support Team for a compatibility check](#)