

# Technical Support Center: Structure-Guided Optimization of GW461484A

**Author:** BenchChem Technical Support Team. **Date:** April 2026

## Compound of Interest

Compound Name: GW461484A

Cat. No.: B15621813

[Get Quote](#)

This technical support center provides troubleshooting guides and frequently asked questions (FAQs) for researchers, scientists, and drug development professionals working on the structure-guided optimization of **GW461484A** to enhance its efficacy as a Yck2 inhibitor for antifungal applications.

## Frequently Asked Questions (FAQs)

Q1: What is the primary target of **GW461484A** and its optimized analogs in the context of antifungal research?

A1: The primary molecular target is Yck2, a casein kinase 1 (CK1) family member in *Candida albicans*.<sup>[1][2][3]</sup> **GW461484A** was initially developed as an inhibitor of human p38 $\alpha$  mitogen-activated protein kinase.<sup>[1]</sup> However, it was repurposed as an antifungal agent upon discovering its potent activity against *C. albicans*.<sup>[1][2]</sup>

Q2: What are the key optimized analogs of **GW461484A**?

A2: Structure-guided optimization and metabolic profiling of **GW461484A** have led to the development of several analogs with improved properties. Notable examples include YK-I-02

and MN-I-157, which exhibit decreased hepatic clearance and enhanced pharmacokinetic profiles.[2]

Q3: What is the mechanism of action of **GW461484A** and its analogs against *Candida albicans*?

A3: **GW461484A** and its analogs act as ATP-competitive inhibitors of Yck2.[2] Yck2 is a crucial kinase involved in fungal morphogenesis, biofilm formation, cell wall integrity, and host cell damage.[1][2] By inhibiting Yck2, these compounds disrupt essential cellular processes in *C. albicans*, leading to antifungal effects.[1]

Q4: How should I prepare and store stock solutions of **GW461484A** and its analogs?

A4: For in vitro biological assays, it is recommended to prepare a high-concentration stock solution (e.g., 10 mM) in a suitable organic solvent like dimethyl sulfoxide (DMSO).[4] To avoid repeated freeze-thaw cycles, which can lead to compound degradation, it is best practice to aliquot the stock solution into smaller, single-use volumes and store them at -20°C or -80°C.[4] Always prepare fresh working solutions from the stock for each experiment.

Q5: What are some common issues encountered when working with pyrazole-based inhibitors like **GW461484A**?

A5: Common challenges include poor aqueous solubility and compound instability. Pyrazole compounds can precipitate in aqueous assay buffers, leading to inconsistent and lower-than-expected effective concentrations.[4] Their stability can also be affected by pH, temperature, and light exposure.[4]

## Troubleshooting Guides

### Issue 1: Inconsistent IC50 or MIC values in replicate experiments.

Possible Causes:

- **Poor Compound Solubility:** The compound may be precipitating out of the solution in your assay medium.[4][5]

- **Compound Instability:** The compound may be degrading over the course of the experiment due to factors like pH, temperature, or light exposure.[4]
- **Pipetting Errors:** Inaccurate or inconsistent pipetting, especially with viscous stock solutions like DMSO, can introduce significant variability.[4]
- **Inconsistent Cell/Enzyme Concentrations:** Variations in the amount of enzyme or the number of cells seeded per well will affect the results.

#### Troubleshooting Steps:

- **Verify Solubility:** Perform a solubility test by preparing the highest concentration of your compound in the final assay buffer and visually inspecting for precipitation. You can also measure turbidity using a plate reader.[6]
- **Optimize Solvent Concentration:** Ensure the final DMSO concentration is consistent across all wells and is non-toxic to the cells (typically below 0.5%). A slight increase in DMSO concentration might improve solubility, but this must be validated.[4]
- **Prepare Fresh Solutions:** Always prepare working dilutions of the compound fresh from a frozen stock immediately before each experiment.[4]
- **Use Proper Pipetting Techniques:** Use calibrated pipettes and ensure thorough mixing when making dilutions. For viscous solutions, consider reverse pipetting.
- **Standardize Assay Conditions:** Ensure consistent cell seeding densities, enzyme concentrations, and incubation times across all experiments.[7]

## Issue 2: Low or no activity in cellular assays despite potent in vitro kinase inhibition.

#### Possible Causes:

- **Poor Cell Permeability:** The compound may not be efficiently crossing the fungal cell wall and membrane to reach its intracellular target, Yck2.

- **Efflux Pump Activity:** The compound might be actively transported out of the fungal cells by efflux pumps.
- **Compound Metabolism:** The compound could be metabolized into an inactive form by the fungal cells.

#### Troubleshooting Steps:

- **Assess Cell Permeability:** While direct measurement can be complex, initial insights can be gained by comparing the in vitro IC50 with the cellular MIC. A large discrepancy may suggest permeability issues.
- **Use Efflux Pump Inhibitors:** To test if efflux is a factor, co-incubate your compound with known fungal efflux pump inhibitors and observe if the antifungal activity increases.
- **Perform Target Engagement Assay:** A NanoBRET Target Engagement assay can confirm if the compound is reaching and binding to Yck2 inside living cells.[\[8\]](#)[\[9\]](#)[\[10\]](#)

## Issue 3: High background signal or variability in the Yck2 Kinase Assay.

#### Possible Causes:

- **Contaminated Reagents:** Contamination in buffers or enzyme preparations can lead to high background signals.
- **Sub-optimal ATP Concentration:** The ATP concentration should be at or near the  $K_m$  for the enzyme to ensure sensitive detection of competitive inhibitors.
- **Assay Plate Issues:** Using plates that are not suitable for the assay (e.g., high-binding surfaces for certain reagents) can cause variability.

#### Troubleshooting Steps:

- **Use High-Quality Reagents:** Ensure all buffers and reagents are freshly prepared with high-purity water and filtered if necessary.

- **Optimize ATP Concentration:** Perform an ATP titration to determine the  $K_m$  for your Yck2 enzyme preparation and use a concentration close to this value in your inhibition assays.
- **Select Appropriate Assay Plates:** Use low-binding plates, especially when working with low concentrations of enzymes and compounds.
- **Include Proper Controls:** Always include "no enzyme" and "no substrate" controls to determine background levels, as well as a positive control inhibitor.

## Quantitative Data Summary

Table 1: In Vitro Potency of **GW461484A** and Analogs against Yck2 and Human Kinases

Compound	Yck2 IC50 ( $\mu\text{M}$ )	Human p38 $\alpha$ IC50 (nM)
GW461484A	0.11[11]	150[1]

Table 2: Antifungal Activity of **GW461484A** against *Candida albicans*

Compound	MIC80 ( $\mu\text{M}$ )
GW461484A	12.5[11]

## Experimental Protocols

### Protocol 1: In Vitro Yck2 Kinase Inhibition Assay (ADP-Glo™ Format)

This protocol outlines the determination of the IC50 value of a test compound against purified Yck2 kinase.

Materials:

- Purified recombinant Yck2 kinase domain
- Yck2-specific peptide substrate

- ADP-Glo™ Kinase Assay Kit (Promega)
- Test compound (e.g., **GW461484A**)
- Assay buffer (e.g., 40 mM Tris, pH 7.5, 20 mM MgCl<sub>2</sub>, 0.1 mg/mL BSA)
- ATP
- DMSO
- White, opaque 384-well assay plates

#### Procedure:

- **Compound Preparation:** Prepare a 10 mM stock solution of the test compound in 100% DMSO. Create a serial dilution series of the compound in DMSO. Further dilute the compound series in the assay buffer to the desired final concentrations. The final DMSO concentration should be consistent across all wells (e.g., <0.5%).[\[4\]](#)
- **Assay Reaction:**
  - Add 5 µL of the diluted compound or control (DMSO vehicle) to the wells of a 384-well plate.[\[4\]](#)
  - Add 10 µL of a solution containing the Yck2 enzyme and peptide substrate in assay buffer.
  - Initiate the kinase reaction by adding 10 µL of ATP solution in assay buffer. The final ATP concentration should be at its K<sub>m</sub> for Yck2.
- **Incubation:** Incubate the plate at room temperature for a predetermined time (e.g., 60 minutes).
- **ADP-Glo™ Reagent Addition:**
  - Add 25 µL of ADP-Glo™ Reagent to each well to stop the kinase reaction and deplete the remaining ATP.
  - Incubate at room temperature for 40 minutes.

- Kinase Detection Reagent Addition:
  - Add 50  $\mu$ L of Kinase Detection Reagent to each well to convert the generated ADP to ATP and produce a luminescent signal.
  - Incubate at room temperature for 30-60 minutes.
- Data Acquisition: Measure the luminescence using a plate reader.
- Data Analysis: Calculate the percent inhibition for each compound concentration relative to the DMSO control. Plot the percent inhibition versus the log of the compound concentration and fit the data to a four-parameter logistic equation to determine the IC<sub>50</sub> value.

## Protocol 2: *Candida albicans* Growth Inhibition Assay (Broth Microdilution for MIC)

This protocol determines the Minimum Inhibitory Concentration (MIC) of a compound against *C. albicans*.

Materials:

- *Candida albicans* strain (e.g., ATCC 10231)
- Sabouraud Dextrose Broth (SDB) or RPMI-1640 medium
- Test compound
- Sterile 96-well flat-bottom microtiter plates
- Spectrophotometer
- Incubator (37°C)

Procedure:

- Inoculum Preparation:

- From a fresh culture of *C. albicans* on an agar plate, suspend several colonies in sterile saline.
- Adjust the turbidity of the fungal suspension to match a 0.5 McFarland standard, which corresponds to approximately  $1-5 \times 10^6$  CFU/mL.
- Dilute this suspension in the appropriate broth (e.g., RPMI-1640) to achieve a final inoculum concentration of approximately  $0.5-2.5 \times 10^3$  CFU/mL.[12]
- Compound Dilution:
  - Prepare a serial two-fold dilution of the test compound in the broth directly in the 96-well plate.[12]
- Inoculation:
  - Add the standardized fungal inoculum to each well containing the compound dilutions and to the growth control wells.
- Controls:
  - Growth Control: Wells containing only the medium and the fungal inoculum.
  - Sterility Control: Wells containing only the medium to check for contamination.[12]
- Incubation: Incubate the plates at 37°C for 24-48 hours.[13]
- MIC Determination: The MIC is the lowest concentration of the compound that causes a significant inhibition of visible growth (e.g., an 80% reduction in turbidity) compared to the growth control.[12] This can be determined visually or by reading the optical density at 600 nm with a microplate reader.

## Protocol 3: NanoBRET™ Target Engagement Assay

This assay measures the binding of a compound to Yck2 within intact cells.

Materials:

- HEK293 cells (or other suitable host cells)
- Plasmid encoding NanoLuc®-Yck2 fusion protein
- Transfection reagent (e.g., FuGENE® HD)
- Opti-MEM® I Reduced Serum Medium
- NanoBRET™ Tracer specific for Yck2
- Test compound
- White, non-binding surface 96-well or 384-well plates
- NanoBRET™ Nano-Glo® Substrate and Extracellular NanoLuc® Inhibitor
- Plate reader capable of measuring filtered luminescence (450 nm and >600 nm)

#### Procedure:

- Cell Transfection:
  - Transfect HEK293 cells with the NanoLuc®-Yck2 fusion vector according to the transfection reagent manufacturer's protocol.
  - Culture the cells for 18-24 hours to allow for protein expression.[\[9\]](#)
- Cell Plating:
  - Harvest the transfected cells and resuspend them in Opti-MEM®.
  - Dispense the cell suspension into the wells of the assay plate.[\[9\]](#)
- Compound and Tracer Addition:
  - Prepare serial dilutions of the test compound in Opti-MEM®.
  - Add the diluted compound to the wells.

- Add the NanoBRET™ Tracer to all wells at a predetermined optimal concentration.
- Equilibration: Incubate the plate at 37°C in a CO2 incubator for 2 hours to allow the compound and tracer to reach binding equilibrium with the target.[9]
- Substrate Addition and Signal Detection:
  - Add the NanoBRET™ Nano-Glo® Substrate and Extracellular NanoLuc® Inhibitor mixture to each well.
  - Read the plate within 20 minutes, measuring both the donor (NanoLuc®, ~450 nm) and acceptor (Tracer, >600 nm) emission signals.[9]
- Data Analysis:
  - Calculate the NanoBRET™ ratio by dividing the acceptor signal by the donor signal.
  - Plot the NanoBRET™ ratio against the log of the compound concentration and fit the data to determine the IC50 value, which represents the concentration of the compound required to displace 50% of the tracer from Yck2.

## Visualizations

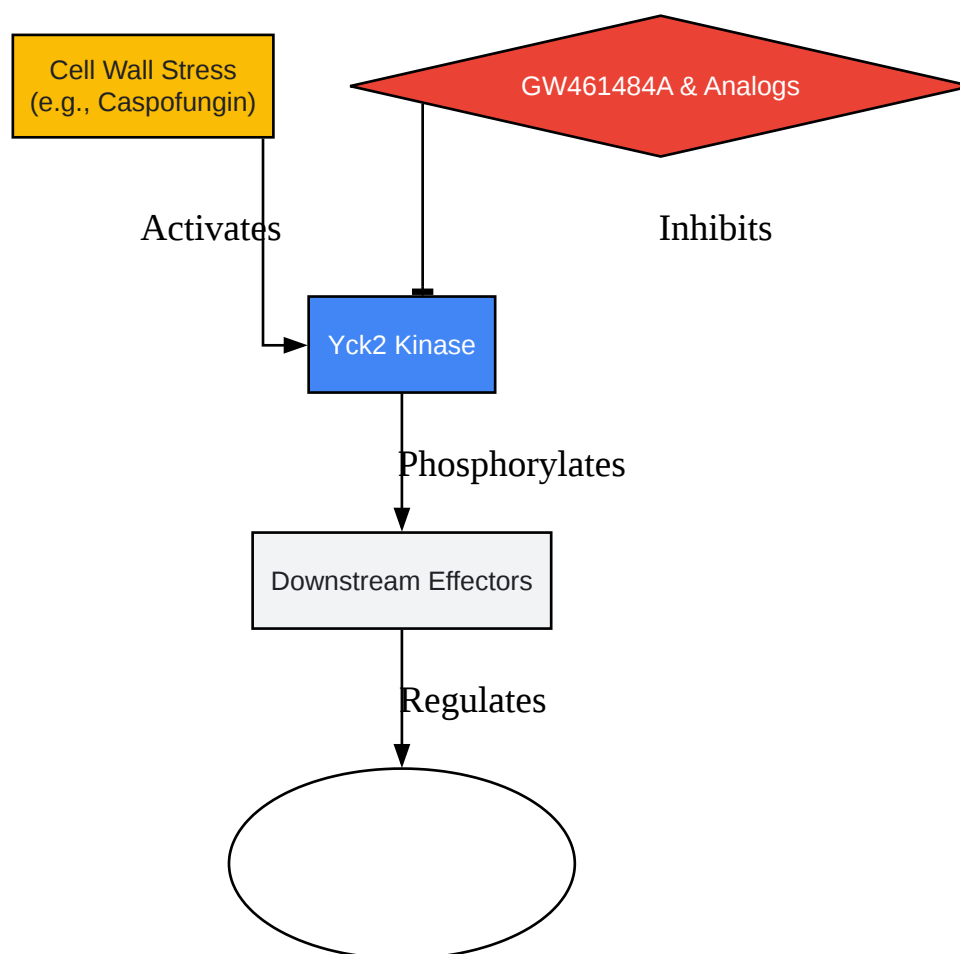

[Click to download full resolution via product page](#)

Caption: Yck2 Signaling Pathway and Point of Inhibition by **GW461484A**.

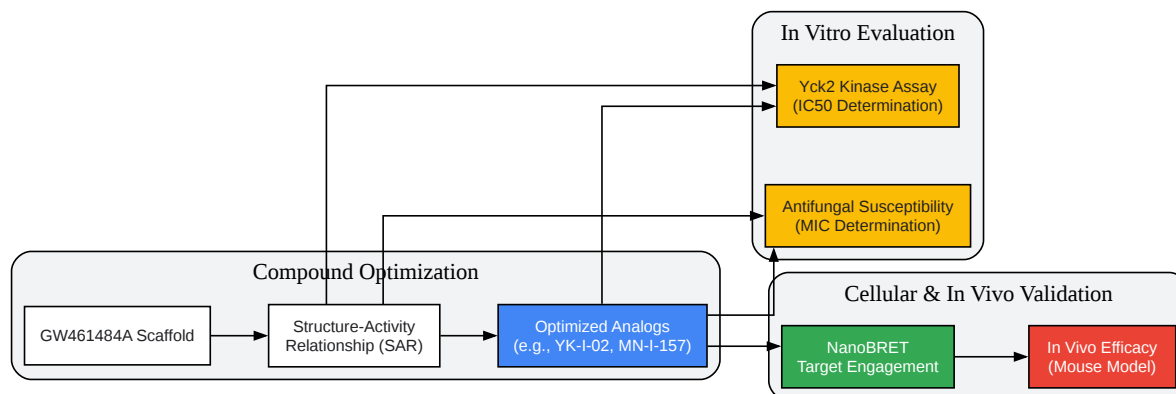

[Click to download full resolution via product page](#)

Caption: Experimental Workflow for **GW461484A** Optimization and Evaluation.

### Need Custom Synthesis?

BenchChem offers custom synthesis for rare earth carbides and specific isotopic labeling.

Email: [info@benchchem.com](mailto:info@benchchem.com) or [Request Quote Online](#).

## References

- 1. Overcoming fungal echinocandin-resistance through inhibition of the non-essential stress kinase Yck2 - PMC [[pmc.ncbi.nlm.nih.gov](https://pubmed.ncbi.nlm.nih.gov/)]
- 2. Chemoproteomic Profiling of *C. albicans* for Characterization of Antifungal Kinase Inhibitors - PMC [[pmc.ncbi.nlm.nih.gov](https://pubmed.ncbi.nlm.nih.gov/)]
- 3. Structure-guided optimization of small molecules targeting the yeast casein kinase, Yck2, as a therapeutic strategy to combat *Candida albicans* - PubMed [[pubmed.ncbi.nlm.nih.gov](https://pubmed.ncbi.nlm.nih.gov/)]
- 4. [benchchem.com](https://www.benchchem.com/) [[benchchem.com](https://www.benchchem.com/)]
- 5. [researchgate.net](https://www.researchgate.net/) [[researchgate.net](https://www.researchgate.net/)]

- [6. benchchem.com \[benchchem.com\]](#)
- [7. benchchem.com \[benchchem.com\]](#)
- [8. NanoBRET® Target Engagement Intracellular Kinase Assay, Adherent Format, Technical Manual \[promega.com\]](#)
- [9. eubopen.org \[eubopen.org\]](#)
- [10. researchgate.net \[researchgate.net\]](#)
- [11. medchemexpress.com \[medchemexpress.com\]](#)
- [12. benchchem.com \[benchchem.com\]](#)
- [13. 4.5. Candida albicans Inhibition Assay \[bio-protocol.org\]](#)
- To cite this document: BenchChem. [Technical Support Center: Structure-Guided Optimization of GW461484A]. BenchChem, [2026]. [Online PDF]. Available at: [\[https://www.benchchem.com/product/b15621813/docs#technical-support-center-structure-guided-optimization-of-gw461484a\]](https://www.benchchem.com/product/b15621813/docs#technical-support-center-structure-guided-optimization-of-gw461484a)

---

#### Disclaimer & Data Validity:

The information provided in this document is for Research Use Only (RUO) and is strictly not intended for diagnostic or therapeutic procedures. While BenchChem strives to provide accurate protocols, we make no warranties, express or implied, regarding the fitness of this product for every specific experimental setup.

**Technical Support:** The protocols provided are for reference purposes. Unsure if this reagent suits your experiment?

**Need Industrial/Bulk Grade?** [Request Custom Synthesis Quote](#)

## BenchChem

Our mission is to be the trusted global source of essential and advanced chemicals, empowering scientists and researchers to drive progress in science and industry.

#### Contact

Address: 3281 E Guasti Rd

Ontario, CA 91761, United States

Phone: (601) 213-4426

Email: [info@benchchem.com](mailto:info@benchchem.com)

Contact our Ph.D. Support Team for a compatibility check