

Technical Support Center: Minimizing CK2-IN-8 Toxicity in Normal Cells

Author: BenchChem Technical Support Team. **Date:** April 2026

Compound of Interest

Compound Name: CK2-IN-8
Cat. No.: B15621728

[Get Quote](#)

This technical support center provides researchers, scientists, and drug development professionals with troubleshooting guides and frequently asked questions (FAQs) to minimize the toxicity of **CK2-IN-8** in normal cells during experiments.

Frequently Asked Questions (FAQs)

Q1: What is **CK2-IN-8** and why is minimizing its toxicity in normal cells important?

CK2-IN-8 is a potent and selective inhibitor of Protein Kinase CK2 (formerly Casein Kinase 2). CK2 is a serine/threonine kinase that is overexpressed in many cancers and plays a crucial role in cell growth, proliferation, and survival.[1][2] While targeting CK2 is a promising anti-cancer strategy, it's also essential for normal cellular functions. Therefore, minimizing the toxicity of **CK2-IN-8** in non-cancerous ("normal") cells is critical to achieve a therapeutic window and to ensure that experimental results accurately reflect the on-target effects in cancer cells.

Q2: What are the primary causes of **CK2-IN-8** toxicity in normal cells?

Toxicity in normal cells can arise from two main sources:

- On-target toxicity: Since CK2 is also active in normal cells, its inhibition can disrupt normal cellular processes. However, many cancer cells exhibit a "non-oncogene addiction" to elevated CK2 levels, making them more sensitive to its inhibition than normal cells.[3]
- Off-target effects: **CK2-IN-8** and its analogs, like CX-4945, can inhibit other kinases, which may lead to unintended biological effects and toxicity.[1][4][5]

Q3: How can I determine if the observed toxicity is on-target or off-target?

Distinguishing between on-target and off-target toxicity is crucial for interpreting your results.

Here are a few strategies:

- Use a structurally different CK2 inhibitor: If a different class of CK2 inhibitor produces the same phenotype, it's more likely to be an on-target effect.
- Rescue experiment: Overexpressing a drug-resistant mutant of CK2 in your cells could rescue the phenotype, indicating an on-target effect.
- Genetic knockdown: Using siRNA or CRISPR to reduce CK2 expression should mimic the on-target effects of the inhibitor. If the phenotypes don't align, off-target effects are likely.
- Cellular Thermal Shift Assay (CETSA): This assay can confirm direct binding of **CK2-IN-8** to CK2 in your cells.

Troubleshooting Guide

This guide addresses specific issues you may encounter when using **CK2-IN-8**.

Issue 1: High cytotoxicity observed in normal cell lines at effective concentrations.

- Possible Cause: The concentration of **CK2-IN-8** is too high, leading to significant on-target or off-target toxicity.
- Troubleshooting Steps:
 - Perform a dose-response curve: Determine the lowest effective concentration that inhibits CK2 activity in your cancer cell model without causing excessive toxicity in your normal cell control.

- Reduce incubation time: Shorter exposure to the inhibitor may be sufficient to achieve the desired effect while minimizing toxicity.
- Use a more selective inhibitor: If available, consider using a CK2 inhibitor with a better selectivity profile.

Issue 2: Discrepancy between the effects of **CK2-IN-8** and CK2 genetic knockdown.

- Possible Cause: The observed phenotype with **CK2-IN-8** is due to off-target effects.
- Troubleshooting Steps:
 - Consult kinase selectivity data: Review published data on the off-target profile of **CK2-IN-8** and its analogs (see Table 1).
 - Inhibit known off-targets: If known off-targets are expressed in your cell line, use specific inhibitors for those kinases to see if the phenotype is replicated.
 - Perform a kinome-wide screen: If resources permit, a kinome-wide screen can identify the specific off-targets of **CK2-IN-8** in your experimental system.

Issue 3: Variability in results between different normal cell lines.

- Possible Cause: Different cell lines have varying expression levels of CK2 and its off-target kinases, as well as different dependencies on these signaling pathways.
- Troubleshooting Steps:
 - Characterize your cell lines: Perform Western blotting to determine the expression levels of CK2 α , CK2 α' , and key off-target kinases in your normal cell lines.
 - Choose appropriate controls: Select normal cell lines that are most relevant to the cancer type you are studying (e.g., normal breast epithelial cells for breast cancer research).

Data Presentation

Table 1: Off-Target Profile of CX-4945 (a close analog of **CK2-IN-8**) and TBB

Kinase	CX-4945 IC50 (nM)	TBB IC50 (μM)	Potential Implication of Off-Target Inhibition
CK2	1	0.9	On-target
PIM1	46	1.04	Cell cycle progression, apoptosis
HIPK3	45	-	Apoptosis, developmental processes
CLK3	41	-	Splicing regulation
FLT3	35	-	Hematopoiesis, cell survival
TBK1	35	-	Innate immunity
DAPK3	17	-	Apoptosis
DYRK1A	160	-	Neuronal development, cell proliferation
GSK3β	190	11.2	Glycogen metabolism, cell adhesion, proliferation
CDK2	-	15.6	Cell cycle regulation

Data compiled from multiple sources.[\[5\]](#)[\[6\]](#)[\[7\]](#)[\[8\]](#)

Experimental Protocols

Cell Viability Assay (MTT Assay)

Objective: To determine the cytotoxic effects of **CK2-IN-8** and establish a dose-response curve.

Methodology:

- Cell Seeding: Plate cells in a 96-well plate at a density of 5,000-10,000 cells/well and allow them to attach overnight.
- Inhibitor Treatment: Treat cells with a serial dilution of **CK2-IN-8** (e.g., 0.1 to 100 μ M) for the desired duration (e.g., 24, 48, or 72 hours). Include a vehicle control (DMSO).
- MTT Addition: Add 10 μ L of 5 mg/mL MTT solution to each well and incubate for 2-4 hours at 37°C.
- Formazan Solubilization: Remove the medium and add 100 μ L of DMSO to each well to dissolve the formazan crystals.
- Absorbance Measurement: Measure the absorbance at 570 nm using a microplate reader.
- Data Analysis: Calculate the percentage of cell viability relative to the vehicle control and plot the dose-response curve to determine the IC50 value.[\[9\]](#)

Apoptosis Assay (Annexin V/PI Staining)

Objective: To quantify the percentage of apoptotic and necrotic cells following treatment with **CK2-IN-8**.

Methodology:

- Cell Treatment: Treat cells with **CK2-IN-8** at the desired concentrations and for the appropriate time.
- Cell Harvesting: Collect both adherent and floating cells and wash them with cold PBS.
- Staining: Resuspend the cells in 1X Annexin V binding buffer. Add fluorescently labeled Annexin V and Propidium Iodide (PI) to the cell suspension.[\[10\]](#)[\[11\]](#)[\[12\]](#)[\[13\]](#)
- Incubation: Incubate the cells for 15 minutes at room temperature in the dark.
- Flow Cytometry Analysis: Analyze the stained cells by flow cytometry.
 - Annexin V-negative/PI-negative: Live cells

- Annexin V-positive/PI-negative: Early apoptotic cells
- Annexin V-positive/PI-positive: Late apoptotic/necrotic cells

Cellular Thermal Shift Assay (CETSA)

Objective: To confirm the direct binding of **CK2-IN-8** to CK2 within intact cells.

Methodology:

- Cell Treatment: Treat intact cells with **CK2-IN-8** or a vehicle control.
- Heat Challenge: Heat the cell lysates or intact cells across a range of temperatures.
- Lysis and Centrifugation: Lyse the cells and centrifuge to separate the soluble protein fraction from the aggregated, denatured proteins.
- Protein Quantification: Collect the supernatant and quantify the amount of soluble CK2 protein using Western blotting.
- Data Analysis: Plot the amount of soluble CK2 as a function of temperature. A shift in the melting curve to a higher temperature in the presence of **CK2-IN-8** indicates target engagement.

Mandatory Visualizations

Signaling Pathways Involving CK2

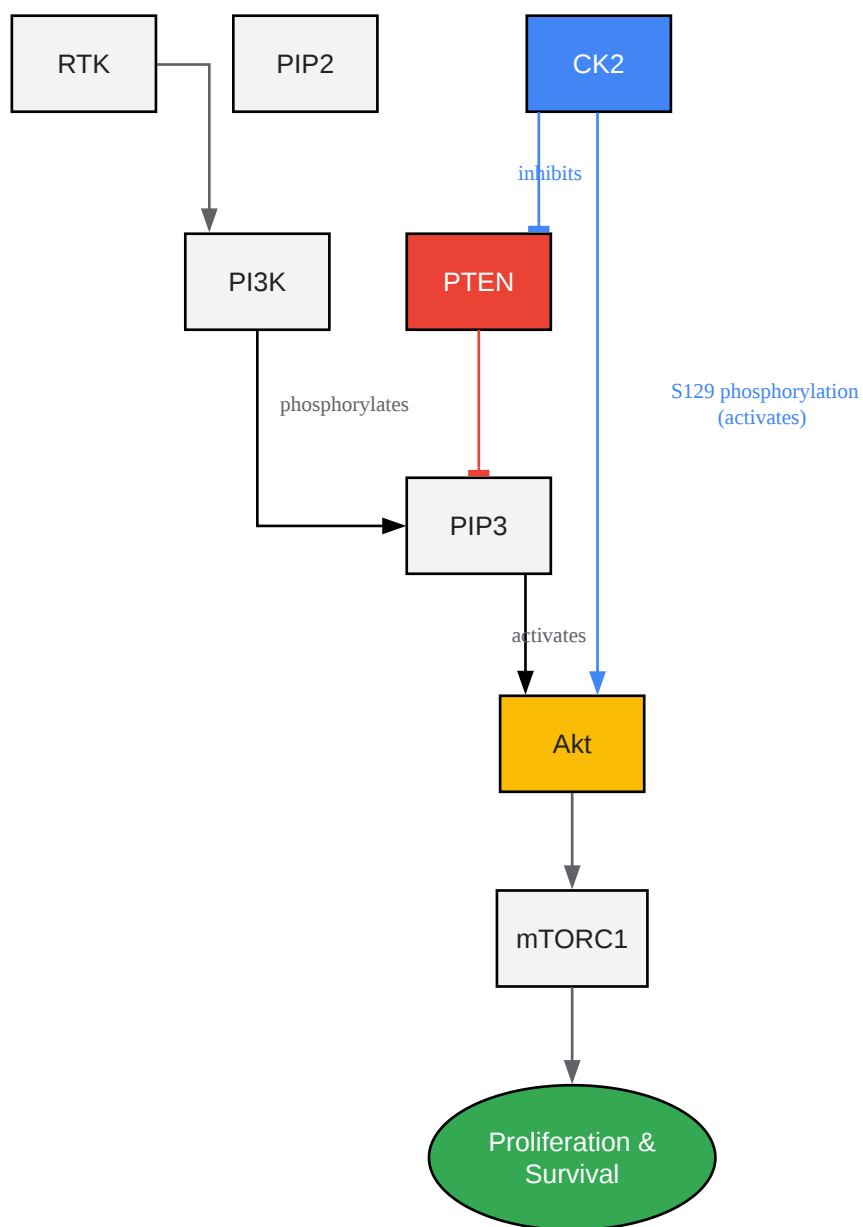

[Click to download full resolution via product page](#)

Caption: CK2 positively regulates the PI3K/Akt/mTOR pathway.[14][15][16][17][18]

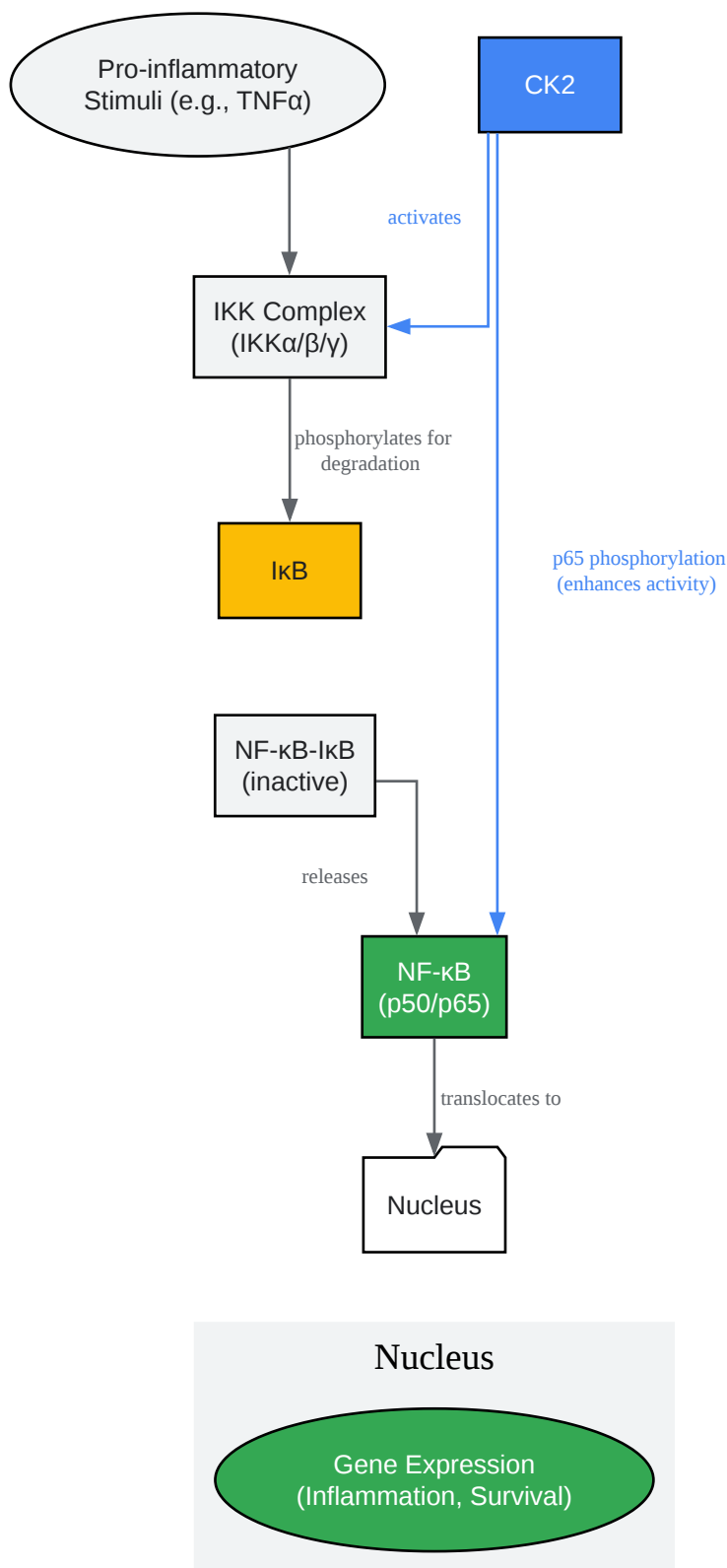

[Click to download full resolution via product page](#)

Caption: CK2 promotes NF-κB signaling at multiple levels.[14][19][20][21][22]

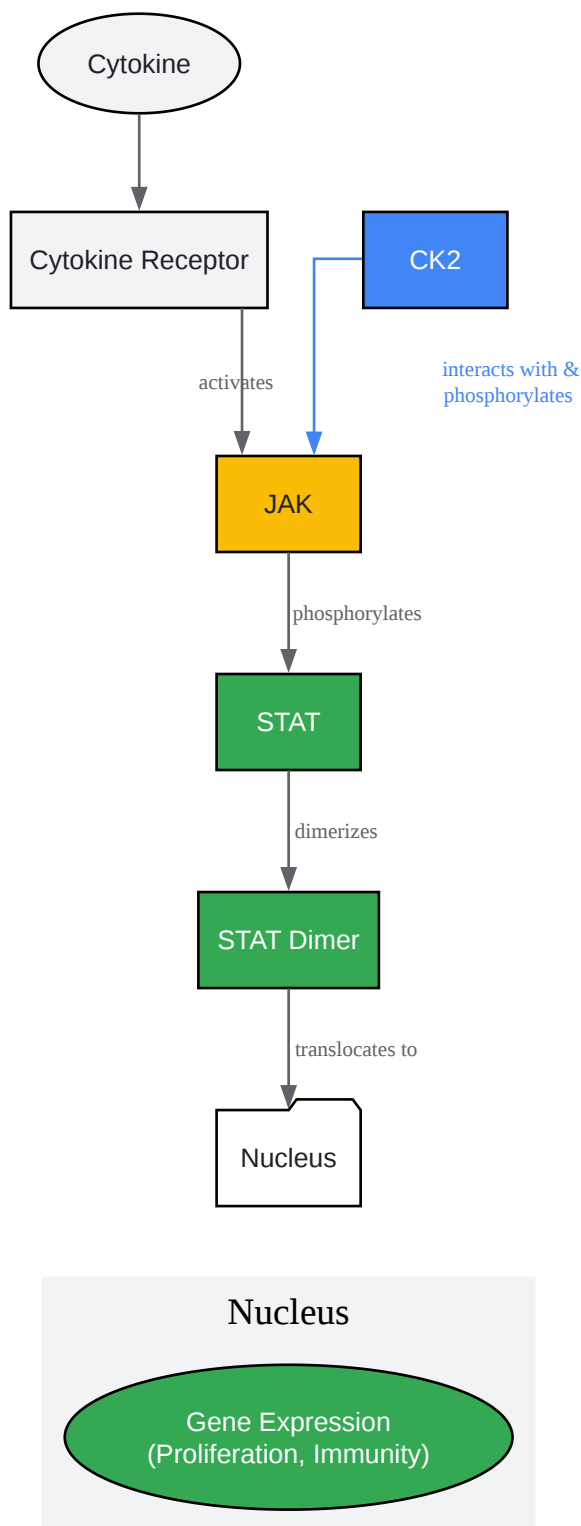

[Click to download full resolution via product page](#)

Caption: CK2 is a positive regulator of the JAK/STAT pathway.[14][23][24][25][26][27]

Experimental Workflow

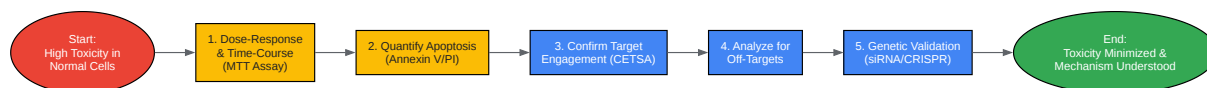

[Click to download full resolution via product page](#)

Caption: Troubleshooting workflow for addressing **CK2-IN-8** toxicity.

Need Custom Synthesis?

BenchChem offers custom synthesis for rare earth carbides and specific isotopic labeling.

Email: info@benchchem.com or [Request Quote Online](#).

References

- 1. Comparative Efficacy of CK2 Inhibitors CX-4945 and SGC-CK2-2 on CK2 Signaling - PubMed [pubmed.ncbi.nlm.nih.gov]
- 2. Different Persistence of the Cellular Effects Promoted by Protein Kinase CK2 Inhibitors CX-4945 and TDB - PMC [pmc.ncbi.nlm.nih.gov]
- 3. researchgate.net [researchgate.net]
- 4. researchgate.net [researchgate.net]
- 5. pubs.acs.org [pubs.acs.org]
- 6. medchemexpress.com [medchemexpress.com]
- 7. Probe CX-4945 | Chemical Probes Portal [chemicalprobes.org]
- 8. Silmitasertib (CX-4945), a Clinically Used CK2-Kinase Inhibitor with Additional Effects on GSK3 β and DYRK1A Kinases: A Structural Perspective - PMC [pmc.ncbi.nlm.nih.gov]
- 9. benchchem.com [benchchem.com]
- 10. Protocol for Apoptosis Assay by Flow Cytometry Using Annexin V Staining Method - PMC [pmc.ncbi.nlm.nih.gov]

- [11. Annexin V and PI Staining Protocol for Apoptosis by Flow Cytometry | Bio-Techne \[bio-technne.com\]](#)
- [12. bosterbio.com \[bosterbio.com\]](#)
- [13. kumc.edu \[kumc.edu\]](#)
- [14. researchgate.net \[researchgate.net\]](#)
- [15. researchgate.net \[researchgate.net\]](#)
- [16. researchgate.net \[researchgate.net\]](#)
- [17. PI3K / Akt Signaling | Cell Signaling Technology \[cellsignal.com\]](#)
- [18. PI3K/AKT/mTOR pathway - Wikipedia \[en.wikipedia.org\]](#)
- [19. NF- \$\kappa\$ B Signaling | Cell Signaling Technology \[cellsignal.com\]](#)
- [20. Protein kinase CK2 in health and disease: CK2 and its role in Wnt and NF-kappaB signaling: linking development and cancer - PubMed \[pubmed.ncbi.nlm.nih.gov\]](#)
- [21. media.cellsignal.com \[media.cellsignal.com\]](#)
- [22. creative-diagnostics.com \[creative-diagnostics.com\]](#)
- [23. researchgate.net \[researchgate.net\]](#)
- [24. cusabio.com \[cusabio.com\]](#)
- [25. A CK2-dependent mechanism for activation of the JAK-STAT signaling pathway - PMC \[pmc.ncbi.nlm.nih.gov\]](#)
- [26. JAK-STAT signaling pathway - Wikipedia \[en.wikipedia.org\]](#)
- [27. A CK2-dependent mechanism for activation of the JAK-STAT signaling pathway - PubMed \[pubmed.ncbi.nlm.nih.gov\]](#)
- To cite this document: BenchChem. [Technical Support Center: Minimizing CK2-IN-8 Toxicity in Normal Cells]. BenchChem, [2026]. [Online PDF]. Available at: [\[https://www.benchchem.com/product/b15621728/docs#technical-support-center-minimizing-ck2-in-8-toxicity-in-normal-cells\]](https://www.benchchem.com/product/b15621728/docs#technical-support-center-minimizing-ck2-in-8-toxicity-in-normal-cells)

Disclaimer & Data Validity:

The information provided in this document is for Research Use Only (RUO) and is strictly not intended for diagnostic or therapeutic procedures. While BenchChem strives to provide accurate protocols, we make no warranties, express or implied, regarding the fitness of this product for every specific experimental setup.

Technical Support: The protocols provided are for reference purposes. Unsure if this reagent suits your experiment?

Need Industrial/Bulk Grade? [Request Custom Synthesis Quote](#)

BenchChem

Our mission is to be the trusted global source of essential and advanced chemicals, empowering scientists and researchers to drive progress in science and industry.

Contact

Address: 3281 E Guasti Rd
Ontario, CA 91761, United States
Phone: (601) 213-4426
Email: info@benchchem.com

[Contact our Ph.D. Support Team for a compatibility check](#)