

# Orthogonal Approaches for the Validation of OICR-41103 Findings: A Comparative Guide

**Author:** BenchChem Technical Support Team. **Date:** April 2026

## Compound of Interest

Compound Name: OICR-41103

Cat. No.: B15621836

[Get Quote](#)

This guide provides researchers, scientists, and drug development professionals with a comparative overview of orthogonal experimental approaches to validate the published findings for **OICR-41103**, a potent and selective chemical probe for the DCAF1 WD40 domain. The primary findings for **OICR-41103** include its high-affinity binding to DCAF1, its engagement with DCAF1 in a cellular context, and its ability to disrupt the DCAF1-Vpr protein-protein interaction.

To ensure the robustness and reliability of these findings, it is crucial to employ orthogonal validation methods. These are experimental techniques that rely on different physical principles to interrogate the same biological question, thereby reducing the likelihood of method-specific artifacts and increasing confidence in the results.

## Validation of Binding Affinity and Kinetics

The initial characterization of **OICR-41103**'s binding to the DCAF1 WD40 domain was performed using Surface Plasmon Resonance (SPR), which revealed a high-affinity interaction. To validate these findings, several orthogonal biophysical techniques can be employed.

Comparison of Orthogonal Biophysical Methods for Binding Affinity:

Method	Principle	Key Parameters Measured	Throughput	Sample Consumption	Label-Free
Surface Plasmon Resonance (SPR)	Measures changes in refractive index at a sensor surface upon binding of an analyte to an immobilized ligand.	KD, kon, koff	Medium-High	Low	Yes
Isothermal Titration Calorimetry (ITC)	Measures the heat released or absorbed during a binding event, providing a complete thermodynamic profile of the interaction.[1] [2][3]	KD, $\Delta H$ , $\Delta S$ , n (stoichiometry)	Low	High	Yes
Biolayer Interferometry (BLI)	Measures changes in the interference pattern of light reflected from a biosensor tip as molecules bind and	KD, kon, koff	High	Low	Yes

	dissociate.[4] [5][6][7][8]				
Microscale Thermophoresis (MST)	Measures the directed movement of molecules in a microscopic temperature gradient, which changes upon ligand binding.[9] [10][11][12] [13]	KD	Medium-High	Very Low	No (requires fluorescent label)
Mass Spectrometry (MS)	Measures the mass-to-charge ratio of protein-ligand complexes under non-denaturing conditions to determine binding stoichiometry and affinity. [14]	KD, Stoichiometry	Medium	Low	Yes

## Experimental Protocols:

### Isothermal Titration Calorimetry (ITC):

- Prepare a solution of purified DCAF1 WD40 domain (typically 10-50  $\mu\text{M}$ ) in a suitable buffer (e.g., 50 mM HEPES pH 7.5, 150 mM NaCl).[15]

- Prepare a solution of **OICR-41103** (typically 10-20 times the protein concentration) in the identical buffer.[\[16\]](#) Ensure final DMSO concentrations are matched if the compound is dissolved in DMSO.
- Degas both solutions to prevent bubble formation.
- Load the DCAF1 solution into the sample cell of the ITC instrument and the **OICR-41103** solution into the injection syringe.
- Perform a series of injections (e.g., 20 injections of 2  $\mu$ L each) at a constant temperature (e.g., 25°C).
- Measure the heat change after each injection.
- Analyze the resulting binding isotherm to determine the dissociation constant (KD), enthalpy ( $\Delta$ H), and stoichiometry (n) of the interaction.[\[16\]](#)

## Validation of Cellular Target Engagement

Cellular Thermal Shift Assay (CETSA) and NanoBRET assays were initially used to demonstrate that **OICR-41103** engages with DCAF1 in intact cells. Orthogonal methods can provide further evidence of this crucial aspect of a chemical probe's performance.

Comparison of Orthogonal Methods for Cellular Target Engagement:

Method	Principle	Readout	Throughput	Label-Free
Cellular Thermal Shift Assay (CETSA)	Ligand binding stabilizes the target protein, leading to a higher melting temperature. <a href="#">[17]</a> <a href="#">[18]</a>	Western Blot or Mass Spectrometry	Low-High	Yes
NanoBRET	Measures bioluminescence resonance energy transfer between a NanoLuc-tagged target protein and a fluorescently labeled tracer.	Luminescence/Fluorescence	High	No
Drug Affinity Responsive Target Stability (DARTS)	Ligand binding protects the target protein from proteolytic degradation. <a href="#">[19]</a>	Western Blot or Mass Spectrometry	Low-Medium	Yes
Thermal Proteome Profiling (TPP) / CETSA-MS	A proteome-wide version of CETSA that uses mass spectrometry to identify all proteins stabilized by the compound. <a href="#">[20]</a> <a href="#">[21]</a>	Mass Spectrometry	Low	Yes
Co-immunoprecipitation	A tagged version of a known	Western Blot	Low	No

ion (Co-IP) with a DCAF1 binder is  
tagged displaced by  
competitor OICR-41103,  
leading to a  
reduced Co-IP  
signal.

---

#### Experimental Protocols:

##### Drug Affinity Responsive Target Stability (DARTS):

- Culture cells (e.g., HEK293T) to ~80% confluency.
- Lyse the cells in a non-denaturing lysis buffer.
- Incubate the cell lysate with varying concentrations of **OICR-41103** or a vehicle control for 1 hour at room temperature.
- Perform limited proteolysis by adding a protease (e.g., thermolysin) and incubating for a short period (e.g., 10 minutes).
- Stop the digestion by adding a protease inhibitor and SDS-PAGE loading buffer.
- Analyze the samples by SDS-PAGE and Western blot using an antibody specific for DCAF1.
- Increased DCAF1 band intensity in the presence of **OICR-41103** indicates target engagement and protection from proteolysis.

## Validation of Functional Protein-Protein Interaction Disruption

A key functional finding for **OICR-41103** is its ability to displace the lentiviral Vpr protein from DCAF1. This demonstrates that the probe can modulate the biological function of its target.

#### Comparison of Orthogonal Methods for Protein Displacement:

Method	Principle	Readout	Throughput	In-Cell/In-Vitro
Co-immunoprecipitation (Co-IP)	<p>An antibody against one protein is used to pull down its binding partners. A decrease in the co-precipitated partner indicates displacement.</p> <p><a href="#">[15]</a><a href="#">[22]</a><a href="#">[23]</a><a href="#">[24]</a> <a href="#">[25]</a></p>	Western Blot	Low	In-Cell
Fluorescence Resonance Energy Transfer (FRET)	<p>Measures the transfer of energy between two fluorescently tagged proteins when in close proximity. Displacement leads to a loss of FRET signal.<a href="#">[26]</a></p> <p><a href="#">[27]</a><a href="#">[28]</a><a href="#">[29]</a><a href="#">[30]</a></p>	Fluorescence	Medium-High	In-Cell
Fluorescence Polarization (FP) Displacement Assay	<p>A fluorescently labeled tracer peptide (derived from Vpr) will have high polarization when bound to DCAF1. Displacement by OICR-41103 will decrease polarization.<a href="#">[31]</a></p>	Fluorescence Polarization	High	In-Vitro

---

AlphaLISA / AlphaScreen	<p>A bead-based proximity assay where binding of two tagged proteins brings beads together, generating a chemiluminescent signal.</p> <p>Displacement reduces the signal.</p>	Luminescence	High	In-Vitro
----------------------------	---	--------------	------	----------

---

#### Experimental Protocols:

#### Co-immunoprecipitation (Co-IP):

- Co-transfect cells (e.g., HEK293T) with constructs expressing tagged versions of DCAF1 (e.g., FLAG-DCAF1) and Vpr (e.g., HA-Vpr).
- Treat the transfected cells with varying concentrations of **OICR-41103** or a vehicle control for a specified time (e.g., 4 hours).
- Lyse the cells in a Co-IP lysis buffer.
- Incubate the cell lysates with an anti-FLAG antibody conjugated to beads to immunoprecipitate FLAG-DCAF1.
- Wash the beads to remove non-specific binders.
- Elute the protein complexes from the beads.
- Analyze the eluates by SDS-PAGE and Western blot using both anti-FLAG and anti-HA antibodies. A dose-dependent decrease in the HA-Vpr signal in the FLAG immunoprecipitates indicates displacement by **OICR-41103**.

# Visualizations

## Signaling Pathway Context

The following diagram illustrates the role of DCAF1 in the CRL4 E3 ubiquitin ligase complex and its hijacking by the lentiviral Vpr protein, which is the process **OICR-41103** aims to disrupt.

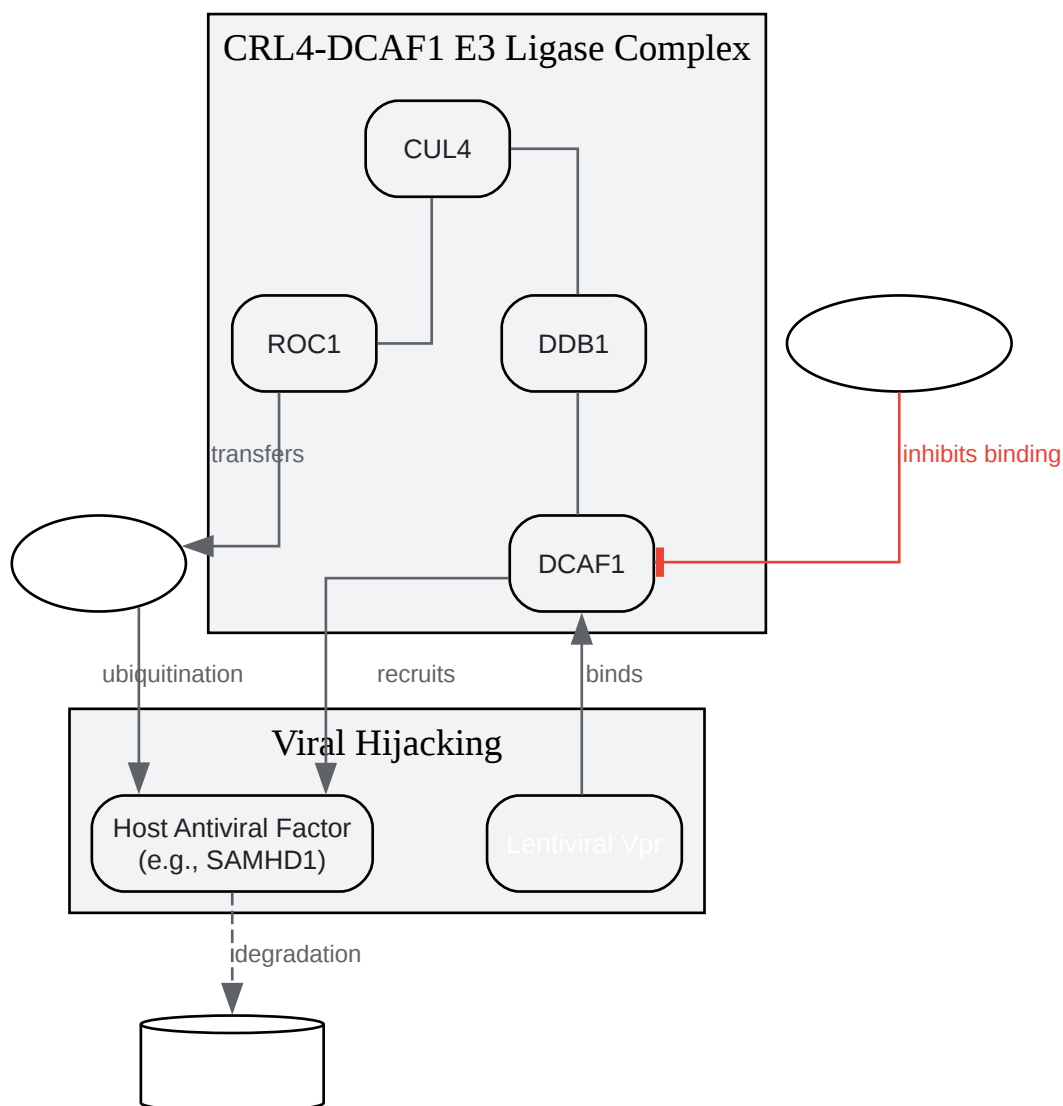

[Click to download full resolution via product page](#)

DCAF1's role in ubiquitination and its inhibition by **OICR-41103**.

## Experimental Workflow: Co-immunoprecipitation

This diagram outlines the key steps in a Co-IP experiment to validate the displacement of Vpr from DCAF1 by **OICR-41103**.



[Click to download full resolution via product page](#)

Workflow for validating protein displacement via Co-IP.

## Logical Relationship: Orthogonal Validation Strategy

This diagram illustrates the logical approach of using multiple, independent methods to strengthen the conclusions about **OICR-41103**'s properties.

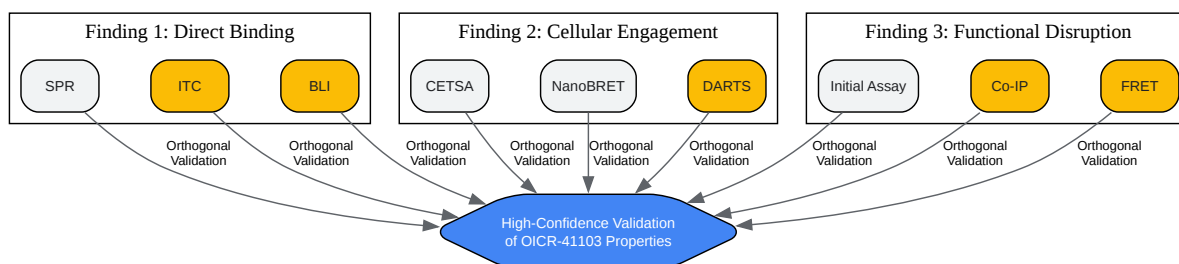

[Click to download full resolution via product page](#)

Convergent evidence from orthogonal methods strengthens conclusions.

### Need Custom Synthesis?

BenchChem offers custom synthesis for rare earth carbides and specific isotopic labeling.

Email: [info@benchchem.com](mailto:info@benchchem.com) or [Request Quote Online](#).

## References

- 1. Analysis of Aptamer-Small Molecule Binding Interactions Using Isothermal Titration Calorimetry - PubMed [pubmed.ncbi.nlm.nih.gov]
- 2. eprints.whiterose.ac.uk [eprints.whiterose.ac.uk]
- 3. Isothermal Titration Calorimetry (ITC) | Center for Macromolecular Interactions [cmi.hms.harvard.edu]
- 4. Biolayer Interferometry (BLI) | Center for Macromolecular Interactions [cmi.hms.harvard.edu]
- 5. Protein-Protein Binding Kinetics by Biolayer Interferometry - PubMed [pubmed.ncbi.nlm.nih.gov]
- 6. Bio-layer interferometry - Wikipedia [en.wikipedia.org]
- 7. Bio-layer Interferometry for Measuring Kinetics of Protein-protein Interactions and Allosteric Ligand Effects [jove.com]
- 8. Determining the Binding Kinetics of Peptide Macrocycles Using Bio-Layer Interferometry (BLI) | Springer Nature Experiments [experiments.springernature.com]
- 9. nanotempertech.com [nanotempertech.com]
- 10. Microscale thermophoresis - Wikipedia [en.wikipedia.org]
- 11. reactionbiology.com [reactionbiology.com]
- 12. Microscale Thermophoresis Quantifies Biomolecular Interactions under Previously Challenging Conditions - PMC [pmc.ncbi.nlm.nih.gov]
- 13. MicroScale Thermophoresis (MST) | Center for Macromolecular Interactions [cmi.hms.harvard.edu]
- 14. Mass spectrometric analysis of protein–ligand interactions - PMC [pmc.ncbi.nlm.nih.gov]
- 15. assaygenie.com [assaygenie.com]
- 16. Isothermal Titration Calorimetry | Biomolecular Interactions Facility | The Huck Institutes (en-US) [huck.psu.edu]
- 17. Comparison of Cellular Target Engagement Methods for the Tubulin Deacetylases Sirt2 and HDAC6: NanoBRET, CETSA, Tubulin Acetylation, and PROTACs - PMC [pmc.ncbi.nlm.nih.gov]
- 18. mdpi.com [mdpi.com]
- 19. DARTS vs CETSA: Choosing the Right Assay for Target Validation - Creative Proteomics [creative-proteomics.com]
- 20. books.rsc.org [books.rsc.org]

- [21. A Shift in Thinking: Cellular Thermal Shift Assay-Enabled Drug Discovery - PMC \[pmc.ncbi.nlm.nih.gov\]](#)
- [22. creative-diagnostics.com \[creative-diagnostics.com\]](#)
- [23. How to conduct a Co-immunoprecipitation \(Co-IP\) | Proteintech Group \[ptglab.com\]](#)
- [24. Co-immunoprecipitation: Principles and applications | Abcam \[abcam.com\]](#)
- [25. The principle and method of co-immunoprecipitation \(Co-IP\) | MBL Life Science - GLOBAL- \[mblbio.com\]](#)
- [26. assaygenie.com \[assaygenie.com\]](#)
- [27. portlandpress.com \[portlandpress.com\]](#)
- [28. Fast Screening of Protein-Protein Interactions Using Förster Resonance Energy Transfer \(FRET-\) Based Fluorescence Plate Reader Assay in Live Cells - PubMed \[pubmed.ncbi.nlm.nih.gov\]](#)
- [29. creative-biostructure.com \[creative-biostructure.com\]](#)
- [30. Video: Assessing Protein Interactions in Live-Cells with FRET-Sensitized Emission \[jove.com\]](#)
- [31. Displacement of protein-bound aptamers with small molecules screened by fluorescence polarization | Springer Nature Experiments \[experiments.springernature.com\]](#)
- [To cite this document: BenchChem. \[Orthogonal Approaches for the Validation of OICR-41103 Findings: A Comparative Guide\]. BenchChem, \[2026\]. \[Online PDF\]. Available at: \[https://www.benchchem.com/product/b15621836/docs#orthogonal-approaches-for-the-validation-of-oicr-41103-findings-a-comparative-guide\]](#)

---

### Disclaimer & Data Validity:

The information provided in this document is for Research Use Only (RUO) and is strictly not intended for diagnostic or therapeutic procedures. While BenchChem strives to provide accurate protocols, we make no warranties, express or implied, regarding the fitness of this product for every specific experimental setup.

**Technical Support:** The protocols provided are for reference purposes. Unsure if this reagent suits your experiment?

**Need Industrial/Bulk Grade?** [Request Custom Synthesis Quote](#)

# BenchChem

Our mission is to be the trusted global source of essential and advanced chemicals, empowering scientists and researchers to drive progress in science and industry.

## Contact

Address: 3281 E Guasti Rd

Ontario, CA 91761, United States

Phone: (601) 213-4426

Email: [info@benchchem.com](mailto:info@benchchem.com)

[Contact our Ph.D. Support Team for a compatibility check](#)