

Optimizing UNC8732 treatment time for maximum protein degradation.

Author: BenchChem Technical Support Team. **Date:** April 2026

Compound of Interest

Compound Name: UNC8732

Cat. No.: B15621556

[Get Quote](#)

Technical Support Center: UNC8732-Mediated Protein Degradation

This technical support center provides researchers, scientists, and drug development professionals with comprehensive guidance on utilizing **UNC8732** for targeted protein degradation. Here you will find troubleshooting guides, frequently asked questions (FAQs), detailed experimental protocols, and visual aids to optimize your experiments for maximum protein degradation.

Frequently Asked Questions (FAQs)

Q1: What is **UNC8732** and what is its mechanism of action?

A1: **UNC8732** is a second-generation, potent, and selective degrader of the nuclear receptor-binding SET domain-containing protein 2 (NSD2).^{[1][2]} It functions as a targeted protein degrader by recruiting the F-box only protein 22 (FBXO22), a substrate recognition component of the SCF (SKP1-CUL1-F-box) E3 ubiquitin ligase complex, to NSD2.^{[1][2]} The primary amine group on **UNC8732** is metabolized within the cell to an aldehyde, which then forms a covalent, yet reversible, bond with a cysteine residue (C326) on FBXO22.^{[1][3][4][5]} This induced

proximity between NSD2 and the E3 ligase complex leads to the polyubiquitination of NSD2, marking it for degradation by the proteasome.[1][2]

Q2: What is the primary protein target of **UNC8732**?

A2: The primary target of **UNC8732** is NSD2, a histone methyltransferase that specifically dimethylates histone H3 at lysine 36 (H3K36me2).[1][2] Overexpression and gain-of-function mutations of NSD2 are implicated in various cancers, including acute lymphoblastic leukemia and multiple myeloma.[1][2]

Q3: How do I determine the optimal treatment time for **UNC8732** in my cell line?

A3: The optimal treatment time for maximal NSD2 degradation can vary between cell lines and experimental conditions. A time-course experiment is essential to determine the ideal duration. We recommend treating your cells with a fixed concentration of **UNC8732** (e.g., the concentration at which you observe maximum degradation, Dmax) for various time points (e.g., 2, 4, 8, 12, 24, and 48 hours).[6] Protein degradation can be assessed at each time point by Western blot to identify when the lowest level of NSD2 is achieved. Some degraders can show significant effects within a few hours, while others may require longer incubation.[7]

Q4: What is the "hook effect" and how can I avoid it with **UNC8732**?

A4: The "hook effect" is a phenomenon observed with bifunctional molecules like PROTACs and other protein degraders where an increase in concentration beyond an optimal point leads to a decrease in degradation efficiency. This occurs because at very high concentrations, the degrader is more likely to form binary complexes (**UNC8732**-NSD2 or **UNC8732**-FBXO22) rather than the productive ternary complex (NSD2-**UNC8732**-FBXO22) required for degradation. To avoid this, it is crucial to perform a dose-response experiment with a wide range of **UNC8732** concentrations (e.g., 1 nM to 10 μ M) to identify the optimal concentration for maximal degradation (Dmax) and the concentration at which 50% degradation is observed (DC50).[7]

Troubleshooting Guide

Issue	Possible Cause	Suggested Solution
No or minimal NSD2 degradation observed.	<p>1. Suboptimal UNC8732 concentration: The concentration may be too low or too high (due to the hook effect). 2. Inappropriate treatment time: The incubation period may be too short to observe degradation.[7][8] 3. Low expression of FBXO22: The cell line used may not express sufficient levels of the FBXO22 E3 ligase. 4. Compound instability: UNC8732 may be unstable in the cell culture medium.</p>	<p>1. Perform a dose-response experiment with a broad range of UNC8732 concentrations (e.g., 1 nM to 10 μM) to determine the optimal concentration.[7] 2. Conduct a time-course experiment (e.g., 2, 4, 8, 16, 24, 48 hours) to identify the optimal treatment duration.[7][6] 3. Verify the expression of FBXO22 in your cell line using Western blot or qPCR. If expression is low, consider using a different cell line. 4. Ensure proper storage of UNC8732 and prepare fresh solutions for each experiment.</p>
High variability between experiments.	<p>1. Inconsistent cell confluency: The number of cells at the time of treatment can affect the outcome. 2. Inconsistent reagent preparation: Variations in the concentration of UNC8732 or other reagents.[9] 3. Variations in incubation conditions: Fluctuations in temperature or CO2 levels.</p>	<p>1. Seed cells at a consistent density to ensure they reach a similar confluency (e.g., 70-80%) at the time of treatment. 2. Prepare fresh stock solutions of UNC8732 and other reagents, and use precise pipetting techniques.[9] 3. Ensure consistent incubation conditions for all experiments.</p>
Off-target effects observed.	<p>1. High concentration of UNC8732: Using concentrations significantly above the Dmax may lead to non-specific effects. 2. Prolonged treatment time: Long incubation times can lead</p>	<p>1. Use the lowest effective concentration of UNC8732 that achieves maximal NSD2 degradation. 2. Use the shortest treatment time necessary to observe maximal degradation. Consider</p>

to secondary effects not directly related to NSD2 degradation.[8]

performing proteomics studies at early time points (e.g., <6 hours) to identify direct targets. [8]

Quantitative Data Summary

The following table summarizes quantitative data from a study using **UNC8732** in U2OS cells.

Cell Line	Treatment	Duration	Key Finding	Reference
U2OS	2 μ M UNC8732	3 hours	Highly selective degradation of NSD2 protein observed in total proteome analysis.	[2][10]
RCH-ACV	0-10 μ M UNC8732	11 days	Dramatic degradation of NSD2 protein and reduction of H3K36me2 levels.	[1]

Experimental Protocols

Protocol 1: Time-Course Experiment for NSD2 Degradation

This protocol outlines the steps to determine the optimal treatment time for **UNC8732**.

- **Cell Seeding:** Seed the cells of interest in a 6-well plate at a density that will allow them to reach 70-80% confluency at the time of harvest.
- **UNC8732 Treatment:** The following day, treat the cells with **UNC8732** at a predetermined concentration (e.g., the Dmax concentration if known, or a concentration from a pilot

experiment, such as 2 μM). Include a vehicle control (e.g., DMSO).

- Incubation: Incubate the cells for various time points (e.g., 0, 2, 4, 8, 12, 24, and 48 hours).
- Cell Lysis: At each time point, wash the cells with ice-cold PBS and lyse them using RIPA buffer supplemented with protease and phosphatase inhibitors.
- Protein Quantification: Determine the protein concentration of each cell lysate using a BCA assay.
- Western Blot Analysis: Analyze the levels of NSD2 protein at each time point using Western blotting, as described in Protocol 3.

Protocol 2: Dose-Response Experiment for NSD2 Degradation

This protocol is for determining the optimal concentration of **UNC8732**.

- Cell Seeding: Seed cells in a 6-well plate to reach 70-80% confluency at harvest.
- **UNC8732** Treatment: Treat the cells with a serial dilution of **UNC8732** (e.g., 1 nM, 10 nM, 100 nM, 1 μM , 10 μM) and a vehicle control (DMSO).
- Incubation: Incubate the cells for the optimal time determined in the time-course experiment.
- Cell Lysis and Protein Quantification: Follow steps 4 and 5 from Protocol 1.
- Western Blot Analysis: Analyze NSD2 protein levels for each concentration using Western blotting (Protocol 3).

Protocol 3: Western Blot Analysis of Protein Degradation

This protocol details the Western blot procedure to quantify protein levels.

- Sample Preparation: Normalize the protein concentration of all samples. Add Laemmli sample buffer and heat the samples at 95°C for 5 minutes.

- Gel Electrophoresis: Load equal amounts of protein (e.g., 20-30 μg) into each well of an SDS-PAGE gel. Run the gel to separate the proteins by size.
- Protein Transfer: Transfer the separated proteins to a PVDF or nitrocellulose membrane.
- Immunoblotting:
 - Block the membrane with 5% non-fat milk or BSA in TBST for 1 hour.
 - Incubate the membrane with a primary antibody against NSD2 overnight at 4°C.
 - Wash the membrane and incubate with an appropriate HRP-conjugated secondary antibody for 1 hour at room temperature.
 - Also probe for a loading control protein (e.g., GAPDH, β -actin) to ensure equal protein loading.
- Detection and Analysis: Develop the blot using an ECL substrate and capture the chemiluminescent signal. Quantify the band intensities using densitometry software. Normalize the NSD2 band intensity to the loading control.

Visualizations

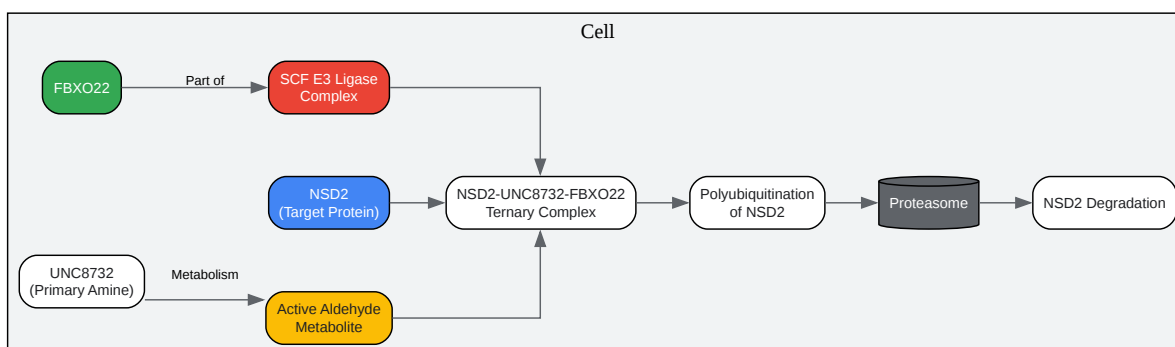

[Click to download full resolution via product page](#)

Caption: **UNC8732** mechanism of action for NSD2 degradation.

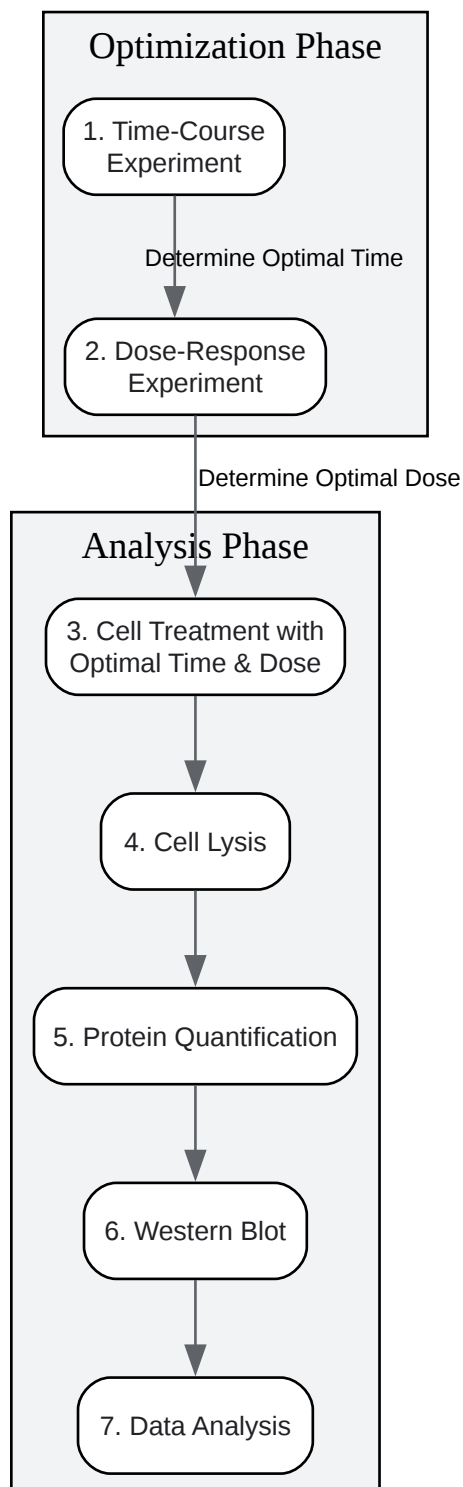

[Click to download full resolution via product page](#)

Caption: Workflow for optimizing **UNC8732** treatment.

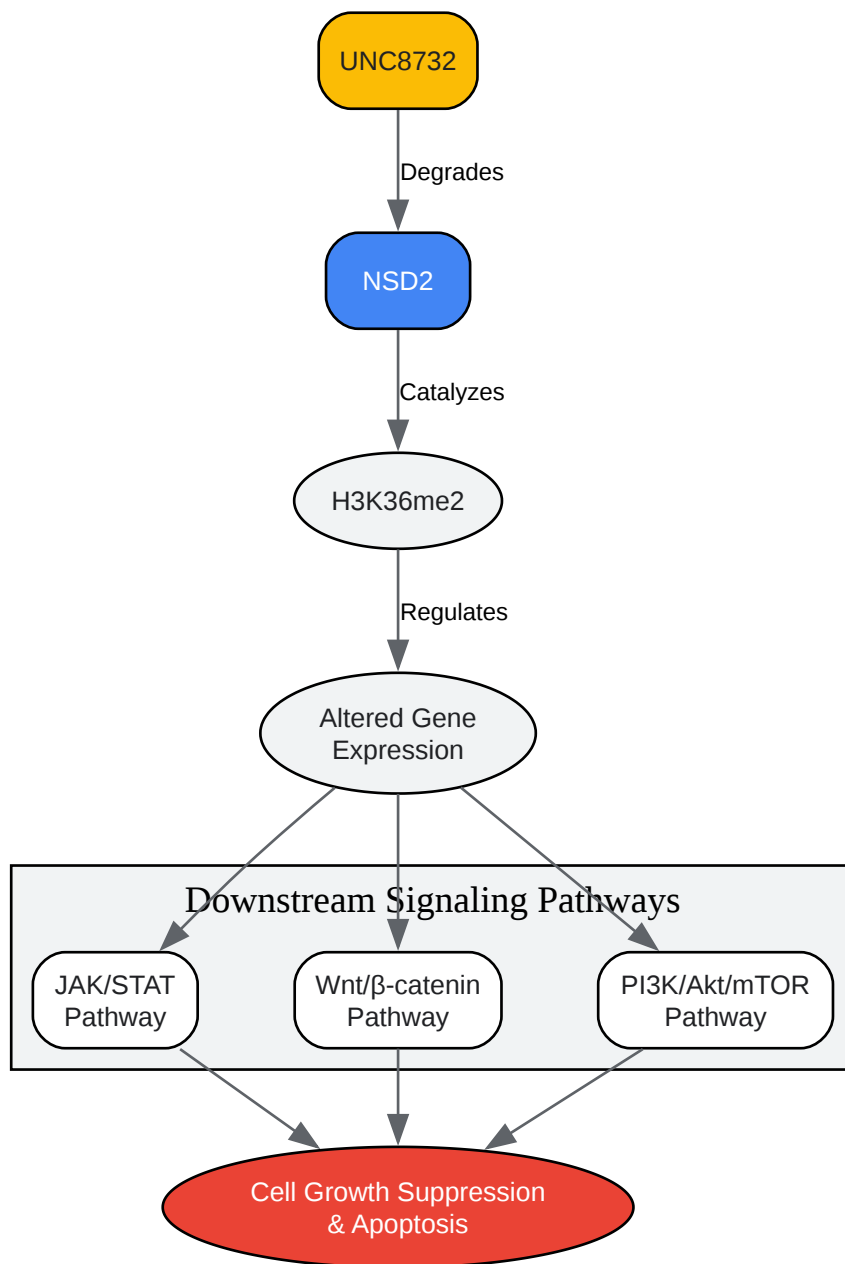

[Click to download full resolution via product page](#)

Caption: Signaling pathways affected by NSD2 degradation.

Need Custom Synthesis?

BenchChem offers custom synthesis for rare earth carbides and specific isotopic labeling.

Email: info@benchchem.com or [Request Quote Online](#).

References

- [1. benchchem.com \[benchchem.com\]](https://www.benchchem.com)
- [2. Recruitment of FBXO22 for targeted degradation of NSD2 - PMC \[pmc.ncbi.nlm.nih.gov\]](https://pubmed.ncbi.nlm.nih.gov/31111111/)
- [3. researchgate.net \[researchgate.net\]](https://www.researchgate.net/publication/31111111)
- [4. benchchem.com \[benchchem.com\]](https://www.benchchem.com)
- [5. The role of NSD1, NSD2, and NSD3 histone methyltransferases in solid tumors - PMC \[pmc.ncbi.nlm.nih.gov\]](https://pubmed.ncbi.nlm.nih.gov/31111111/)
- [6. researchgate.net \[researchgate.net\]](https://www.researchgate.net/publication/31111111)
- [7. pubs.acs.org \[pubs.acs.org\]](https://pubs.acs.org)
- [8. researchgate.net \[researchgate.net\]](https://www.researchgate.net/publication/31111111)
- [9. FBXO22 Promotes Growth and Metastasis and Inhibits Autophagy in Epithelial Ovarian Cancers via the MAPK/ERK Pathway - PMC \[pmc.ncbi.nlm.nih.gov\]](https://pubmed.ncbi.nlm.nih.gov/31111111/)
- [10. researchgate.net \[researchgate.net\]](https://www.researchgate.net/publication/31111111)
- To cite this document: BenchChem. [Optimizing UNC8732 treatment time for maximum protein degradation.]. BenchChem, [2026]. [Online PDF]. Available at: [\[https://www.benchchem.com/product/b15621556/docs#optimizing-unc8732-treatment-time-for-maximum-protein-degradation\]](https://www.benchchem.com/product/b15621556/docs#optimizing-unc8732-treatment-time-for-maximum-protein-degradation)

Disclaimer & Data Validity:

The information provided in this document is for Research Use Only (RUO) and is strictly not intended for diagnostic or therapeutic procedures. While BenchChem strives to provide accurate protocols, we make no warranties, express or implied, regarding the fitness of this product for every specific experimental setup.

Technical Support: The protocols provided are for reference purposes. Unsure if this reagent suits your experiment?

Need Industrial/Bulk Grade? [Request Custom Synthesis Quote](#)

BenchChem

Our mission is to be the trusted global source of essential and advanced chemicals, empowering scientists and researchers to drive progress in science and industry.

Contact

Address: 3281 E Guasti Rd
Ontario, CA 91761, United States
Phone: (601) 213-4426
Email: info@benchchem.com

[Contact our Ph.D. Support Team for a compatibility check](#)