

GNF-7: A Technical Guide to Its Induction of Cell Cycle Arrest

Author: BenchChem Technical Support Team. **Date:** April 2026

Compound of Interest

Compound Name:	GNF-7
CAS No.:	839706-07-9
Cat. No.:	B15621306

[Get Quote](#)

For Researchers, Scientists, and Drug Development Professionals

Abstract

GNF-7 is a potent, orally bioavailable multi-kinase inhibitor that has demonstrated significant anti-proliferative effects in various cancer models. Initially developed as a type-II kinase inhibitor targeting the Bcr-Abl fusion protein, including the T315I mutant, its activity spectrum has been shown to be much broader. A key mechanism contributing to its anti-neoplastic activity is the induction of cell cycle arrest, primarily at the G1/S transition. This technical guide provides an in-depth overview of the core mechanisms, quantitative data, experimental protocols, and signaling pathways associated with **GNF-7**-mediated cell cycle arrest.

Mechanism of Action

GNF-7 functions as a multi-kinase inhibitor, binding to and inhibiting the activity of a range of kinases involved in cell proliferation and survival. Its primary mechanism for inducing cell cycle arrest is through the inhibition of kinases that are critical for the G1 to S phase transition. In Ewing sarcoma cells, **GNF-7** has been shown to cause a substantial accumulation of cells in

the G1 phase of the cell cycle[1]. This effect is also observed in leukemia cells harboring NRAS mutations, where **GNF-7** induces both cell cycle arrest and apoptosis[2][3].

The induction of G1 arrest is a hallmark of inhibitors targeting the Cyclin D-CDK4/6-Rb pathway[4][5][6][7]. While direct inhibition of CDK4/6 by **GNF-7** has not been explicitly detailed in the provided results, its ability to potently induce G1 arrest suggests an interference with this critical cell cycle checkpoint. The retinoblastoma protein (Rb) acts as a tumor suppressor by restricting entry into the S phase. Phosphorylation of Rb by CDK4/6-Cyclin D complexes leads to its inactivation and allows the cell cycle to progress[5][7]. By inhibiting upstream signaling that leads to CDK4/6 activation, or potentially through direct interaction, **GNF-7** helps maintain Rb in its active, hypophosphorylated state, thereby halting the cell cycle at the G1/S boundary.

Quantitative Data

The anti-proliferative and kinase inhibitory activities of **GNF-7** have been quantified across various cancer cell lines and specific kinase assays. The following tables summarize the key inhibitory concentrations (IC50) and the observed effects on cell cycle distribution.

Table 1: GNF-7 Kinase Inhibitory Activity

Target Kinase	IC50 (nM)	Notes
Bcr-Abl (Wild-Type)	133	[8]
Bcr-Abl (T315I)	61	[8][9]
Bcr-Abl (M351T)	<5	[9][10]
Bcr-Abl (E255V)	122	[9][10]
Bcr-Abl (G250E)	136	[9][10]
c-Abl	133	[9][10]
ACK1	25	[8]
GCK	8	[8]
CSK	>50% inhibition at 40 nM	[1][11][12]
p38α	>50% inhibition at 40 nM	[1][11][12]
EphA2	>50% inhibition at 40 nM	[1][11][12]
Lyn	>50% inhibition at 40 nM	[1][11][12]
ZAK	>50% inhibition at 40 nM	[1][11][12]

Table 2: GNF-7 Anti-proliferative Activity

Cell Line	Cancer Type	IC50 (nM)	Notes
Ba/F3 (Bcr-Abl WT & mutants)	Leukemia	<11	[9]
Colo205	Colon Cancer	5	[9]
SW620	Colon Cancer	1	[9]
EW8 (TOP1 KD)	Ewing Sarcoma	~40	10-fold lower than parental cells[1][12]

Table 3: Effect of GNF-7 on Cell Cycle Distribution in Ewing Sarcoma Cells

Treatment (24h)	% G1 Phase	% S Phase	% G2/M Phase	Cell Line
DMSO	55	35	10	EW8
40 nM GNF-7	75	15	10	EW8
DMSO	58	32	10	EW8 TOP1 KD
40 nM GNF-7	78	12	10	EW8 TOP1 KD

Data extrapolated from graphical representation in cited literature[13].

Signaling Pathways Modulated by GNF-7

GNF-7's multi-targeted nature allows it to interfere with several signaling pathways that are crucial for cell cycle progression. In acute myeloid leukemia (AML) cells with FLT3-ITD mutations, **GNF-7** has been shown to inhibit the downstream signaling pathways activated by FLT3, including STAT5, PI3K/AKT, and MAPK/ERK[14]. Inhibition of these pathways can lead to decreased expression of proteins essential for cell cycle progression, such as cyclins and CDKs.

GNF-7 Inhibition of Pro-Proliferative Signaling

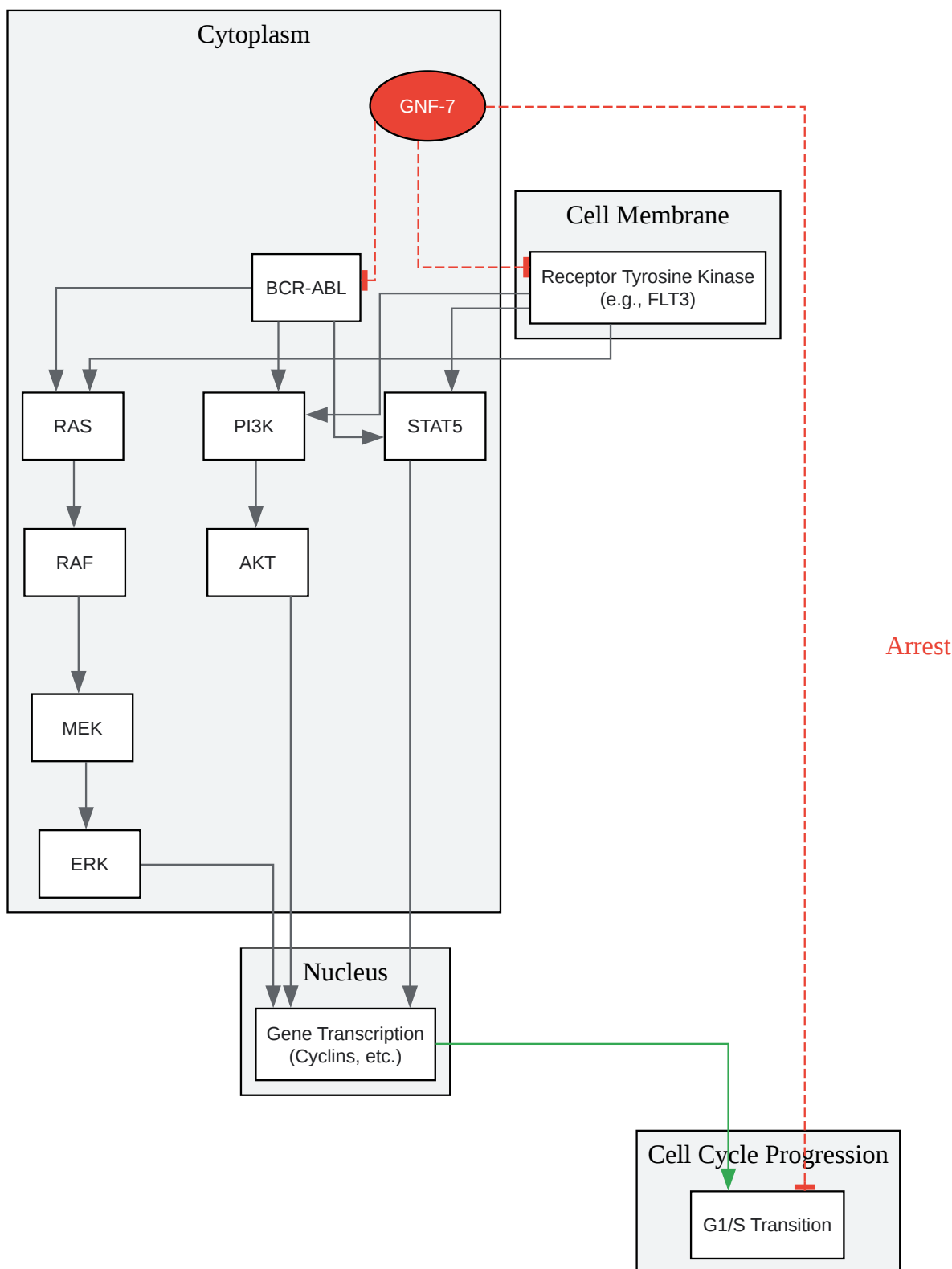

[Click to download full resolution via product page](#)

Caption: **GNF-7** inhibits RTKs and Bcr-Abl, blocking downstream pro-proliferative pathways.

Experimental Protocols

This section provides detailed methodologies for key experiments used to characterize the effects of **GNF-7** on cell cycle arrest.

Cell Cycle Analysis by Flow Cytometry

This protocol is used to determine the distribution of cells in the different phases of the cell cycle based on their DNA content.

Materials:

- **GNF-7** (dissolved in DMSO)
- Cancer cell lines (e.g., EW8)
- Complete cell culture medium
- Phosphate-Buffered Saline (PBS)
- 70% Ethanol (ice-cold)
- Propidium Iodide (PI) staining solution (containing RNase A)
- Flow cytometer

Procedure:

- **Cell Seeding:** Seed cells in 6-well plates at a density that will not exceed 80% confluency at the end of the experiment. Allow cells to adhere overnight.
- **Treatment:** Treat cells with the desired concentrations of **GNF-7** (e.g., 40 nM) or vehicle control (DMSO) for the specified duration (e.g., 24, 48, 72 hours)[1].
- **Cell Harvest:** After treatment, collect both adherent and floating cells. For adherent cells, wash with PBS and detach using trypsin. Combine all cells and centrifuge at 300 x g for 5 minutes.

- **Fixation:** Discard the supernatant and resuspend the cell pellet in 1 mL of ice-cold PBS. Add the cell suspension dropwise into 4 mL of ice-cold 70% ethanol while vortexing gently to prevent clumping. Fix the cells overnight at -20°C[15].
- **Staining:** Centrifuge the fixed cells at 500 x g for 5 minutes and discard the ethanol. Wash the cell pellet with PBS. Resuspend the cells in PI staining solution and incubate for 30 minutes at room temperature in the dark.
- **Flow Cytometry:** Analyze the stained cells using a flow cytometer. The DNA content is measured by the fluorescence intensity of PI. The data is then analyzed using appropriate software to quantify the percentage of cells in the G0/G1, S, and G2/M phases of the cell cycle[15].

In Situ Kinome Profiling (KiNativ™)

This method is used to identify the kinases that are bound and inhibited by **GNF-7** within the cellular environment.

Materials:

- **GNF-7**
- Cell lines of interest (e.g., EW8)
- Cell lysis buffer
- ATP- or ADP-acyl-phosphate probes (KiNativ™ platform)
- LC/MS-MS system

Procedure:

- **Cell Treatment:** Treat cells with **GNF-7** at various concentrations (e.g., 40 nM, 400 nM) and for different durations (e.g., 1 hour, 24 hours) alongside a DMSO control[1].
- **Cell Lysis:** Harvest and lyse the cells to prepare a protein lysate.

- **Probe Labeling:** The cell lysates are labeled with a biotinylated acyl-phosphate probe that covalently modifies the ATP binding site of kinases that are not occupied by the inhibitor[1].
- **Enrichment and Digestion:** The probe-labeled proteins are enriched, typically using streptavidin beads, and then subjected to tryptic digestion.
- **LC/MS-MS Analysis:** The resulting peptides are analyzed by liquid chromatography-tandem mass spectrometry (LC/MS-MS) to identify and quantify the probe-labeled kinases.
- **Data Analysis:** The abundance of probe-labeled peptides from **GNF-7**-treated samples is compared to that from DMSO-treated samples. A decrease in the signal for a particular kinase in the **GNF-7**-treated sample indicates that the kinase was bound and inhibited by **GNF-7**. The percent inhibition is calculated for each identified kinase[1].

Experimental Workflow for **GNF-7** Target Identification and Cell Cycle Analysis

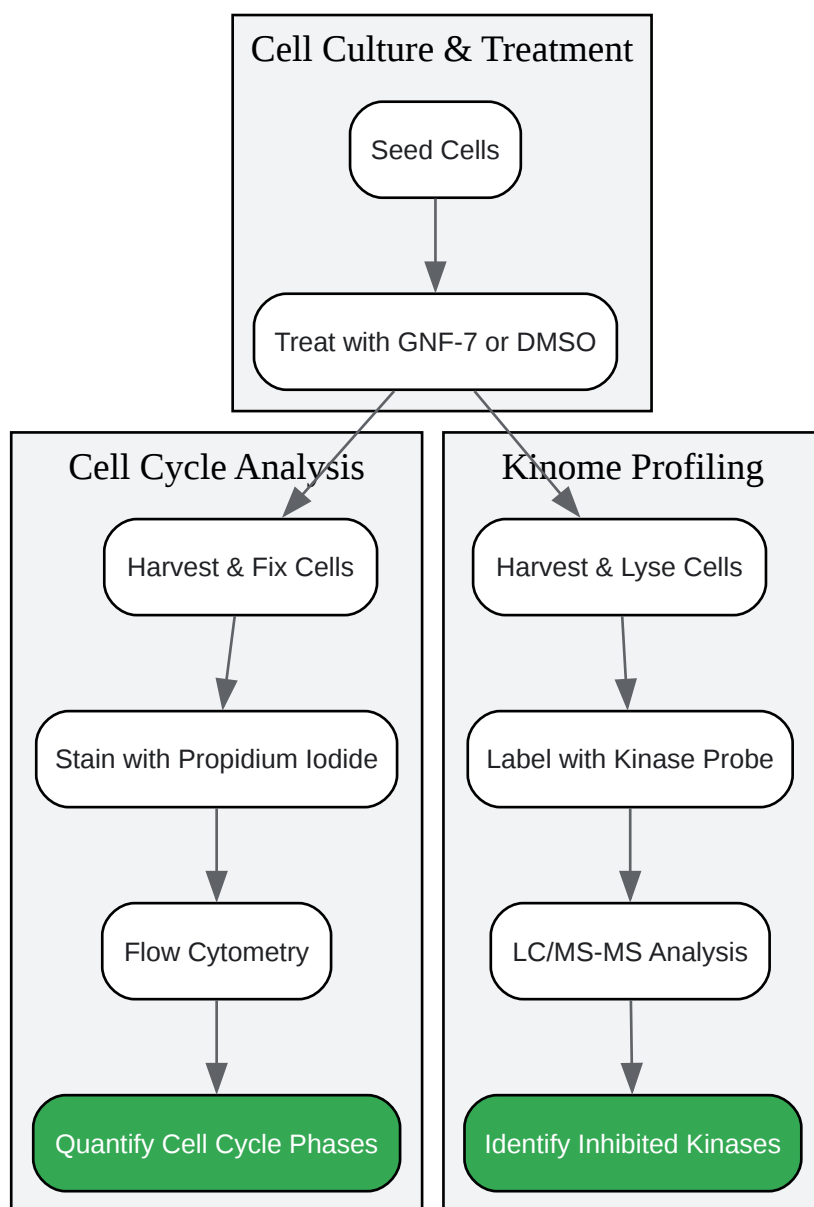

[Click to download full resolution via product page](#)

Caption: Workflow for assessing **GNF-7's** effect on cell cycle and kinase inhibition.

Conclusion

GNF-7 is a multi-kinase inhibitor that effectively induces cell cycle arrest at the G1/S checkpoint in various cancer cell lines. This activity is a result of its ability to inhibit multiple kinases that are integral to pro-proliferative signaling pathways. The quantitative data and experimental protocols provided in this guide offer a comprehensive resource for researchers and drug

development professionals investigating the therapeutic potential of **GNF-7**. Further elucidation of its precise interactions with cell cycle machinery, particularly the CDK4/6-Rb axis, will be crucial in optimizing its clinical application.

Need Custom Synthesis?

BenchChem offers custom synthesis for rare earth carbides and specific isotopic labeling.

Email: info@benchchem.com or [Request Quote Online](#).

References

- [1. mdpi.com \[mdpi.com\]](#)
- [2. GNF 7 | Ras GTPase Inhibitors: R&D Systems \[rndsystems.com\]](#)
- [3. xcessbio.com \[xcessbio.com\]](#)
- [4. mdpi.com \[mdpi.com\]](#)
- [5. Early Adaptation and Acquired Resistance to CDK4/6 Inhibition in Estrogen Receptor–Positive Breast Cancer - PMC \[pmc.ncbi.nlm.nih.gov\]](#)
- [6. CDK4 and CDK6 kinases: from basic science to cancer therapy - PMC \[pmc.ncbi.nlm.nih.gov\]](#)
- [7. resources.revvity.com \[resources.revvity.com\]](#)
- [8. medchemexpress.com \[medchemexpress.com\]](#)
- [9. selleckchem.com \[selleckchem.com\]](#)
- [10. adooq.com \[adooq.com\]](#)
- [11. The Kinase Inhibitor GNF-7 Is Synthetically Lethal in Topoisomerase 1-Deficient Ewing Sarcoma - PMC \[pmc.ncbi.nlm.nih.gov\]](#)
- [12. aacrjournals.org \[aacrjournals.org\]](#)
- [13. researchgate.net \[researchgate.net\]](#)
- [14. GNF-7, a novel FLT3 inhibitor, overcomes drug resistance for the treatment of FLT3-ITD acute myeloid leukemia - PubMed \[pubmed.ncbi.nlm.nih.gov\]](#)
- [15. Trichodermin Induces G0/G1 Cell Cycle Arrest by Inhibiting c-Myc in Ovarian Cancer Cells and Tumor Xenograft-Bearing Mice \[mdpi.com\]](#)

- To cite this document: BenchChem. [GNF-7: A Technical Guide to Its Induction of Cell Cycle Arrest]. BenchChem, [2026]. [Online PDF]. Available at: [<https://www.benchchem.com/product/b15621306/docs#gfn-7-a-technical-guide-to-its-induction-of-cell-cycle-arrest>]

Disclaimer & Data Validity:

The information provided in this document is for Research Use Only (RUO) and is strictly not intended for diagnostic or therapeutic procedures. While BenchChem strives to provide accurate protocols, we make no warranties, express or implied, regarding the fitness of this product for every specific experimental setup.

Technical Support: The protocols provided are for reference purposes. Unsure if this reagent suits your experiment?

Need Industrial/Bulk Grade? [Request Custom Synthesis Quote](#)

BenchChem

Our mission is to be the trusted global source of essential and advanced chemicals, empowering scientists and researchers to drive progress in science and industry.

Contact

Address: 3281 E Guasti Rd
Ontario, CA 91761, United States
Phone: (601) 213-4426
Email: info@benchchem.com

[Contact our Ph.D. Support Team for a compatibility check](#)