

ETP-45658: Application Notes and Protocols for Inducing G1 Phase Arrest

Author: BenchChem Technical Support Team. **Date:** April 2026

Compound of Interest

Compound Name: ETP-45658

Cat. No.: B15621646

[Get Quote](#)

For Researchers, Scientists, and Drug Development Professionals

These application notes provide a comprehensive overview of **ETP-45658**, a potent inhibitor of the PI3K/AKT/mTOR signaling pathway, and its application in inducing G1 phase cell cycle arrest in cancer cells. Detailed protocols for experimental validation are also included.

Introduction

ETP-45658 is a selective inhibitor of phosphoinositide 3-kinases (PI3Ks), targeting multiple isoforms with varying potency.^{[1][2]} It also demonstrates inhibitory activity against DNA-dependent protein kinase (DNA-PK) and the mammalian target of rapamycin (mTOR).^{[1][2]} By targeting the PI3K/AKT/mTOR pathway, a critical regulator of cell proliferation, survival, and metabolism, **ETP-45658** effectively induces a G1 phase arrest in various cancer cell lines.^{[1][3][4]} This activity is characterized as being FOXO-dependent and p53-independent.^{[2][5]}

Mechanism of Action

ETP-45658 exerts its anti-proliferative effects by inhibiting the PI3K/AKT/mTOR signaling cascade. This inhibition leads to a decrease in the phosphorylation of key downstream effectors, including Akt, FOXO3a, Gsk3- β , and p70 S6K.[1] The reduced phosphorylation of Akt prevents the inactivation of the FOXO3a transcription factor, allowing it to translocate to the nucleus and regulate the expression of genes involved in cell cycle arrest. Furthermore, **ETP-45658** treatment has been shown to decrease the expression of Cyclin D1, a key regulator of the G1/S phase transition.[1] The culmination of these molecular events is a robust G1 phase cell cycle arrest.[1][3][4]

Data Presentation

Table 1: Inhibitory Activity of **ETP-45658**

Target	IC50 (nM)
PI3K α	22.0[1][2]
PI3K β	129.0[1][2]
PI3K δ	30 (39.8[1][2])
PI3K γ	710 (717.3[1][2])
DNA-PK	70.6[1][2]
mTOR	152.0[1][2]

Table 2: Anti-proliferative Activity of **ETP-45658** in Cancer Cell Lines

Cell Line	Cancer Type	EC50 (μM)
MCF7	Breast Cancer	0.48[1]
PC3	Prostate Cancer	0.49[1]
786-O	Renal Cancer	2.62[1]
HCT116	Colon Cancer	3.53[1]
U251	Glioblastoma	5.56[1]
HT-29	Colon Cancer	19.3[5]

Experimental Protocols

Protocol 1: Cell Viability Assay (XTT Assay)

This protocol is for determining the cytotoxic effect of **ETP-45658** on cancer cells.

Materials:

- Cancer cell line of interest (e.g., HT-29)
- Complete growth medium
- **ETP-45658** (solubilized in DMSO)
- 96-well plates
- XTT labeling and electron-coupling reagent
- Microplate reader

Procedure:

- Seed cells in a 96-well plate at a density of 1×10^4 cells/well in 100 μL of complete growth medium.
- Incubate the plate for 24 hours at 37°C in a humidified atmosphere with 5% CO₂.

- Prepare serial dilutions of **ETP-45658** in complete growth medium.
- After 24 hours, remove the medium and add 100 μ L of the **ETP-45658** dilutions to the respective wells. Include a vehicle control (DMSO) and a no-treatment control.
- Incubate the cells for the desired time period (e.g., 24, 48, or 72 hours).
- Following incubation, add 50 μ L of the XTT labeling mixture to each well.
- Incubate the plate for 4 hours at 37°C.
- Measure the absorbance of the samples at 450 nm using a microplate reader.
- Calculate the cell viability as a percentage of the control and determine the EC50 value.

Protocol 2: Cell Cycle Analysis by Flow Cytometry

This protocol details the procedure for analyzing the cell cycle distribution of cells treated with **ETP-45658** using propidium iodide (PI) staining.

Materials:

- Cancer cell line of interest
- Complete growth medium
- **ETP-45658**
- Phosphate-buffered saline (PBS)
- 70% Ethanol (ice-cold)
- Propidium Iodide (PI) staining solution (50 μ g/mL PI in PBS)
- RNase A (100 μ g/mL)
- Flow cytometer

Procedure:

- Seed cells in 6-well plates and grow to approximately 70-80% confluency.
- Treat the cells with the desired concentration of **ETP-45658** (e.g., 10 μ M for PC3 cells) or vehicle control for 24 hours.[1]
- Harvest the cells by trypsinization and collect them by centrifugation at 300 x g for 5 minutes.
- Wash the cells once with ice-cold PBS.
- Fix the cells by resuspending the pellet in 1 mL of ice-cold 70% ethanol, adding it dropwise while gently vortexing to prevent clumping.
- Incubate the fixed cells at 4°C for at least 1 hour (or store at -20°C for several weeks).
- Pellet the fixed cells by centrifugation at a higher speed (e.g., 850 x g) for 5 minutes.
- Wash the cells twice with PBS.
- Resuspend the cell pellet in 500 μ L of PI staining solution containing RNase A.
- Incubate the cells in the dark at room temperature for 30 minutes.
- Analyze the samples on a flow cytometer, acquiring at least 10,000 events per sample.
- Use appropriate software to analyze the cell cycle distribution and quantify the percentage of cells in the G1, S, and G2/M phases.

Protocol 3: Western Blot Analysis of Signaling Proteins

This protocol is for assessing the phosphorylation status and expression levels of key proteins in the PI3K/AKT/mTOR pathway following **ETP-45658** treatment.

Materials:

- Cancer cell line of interest
- Complete growth medium
- **ETP-45658**

- Lysis buffer (e.g., RIPA buffer) with protease and phosphatase inhibitors
- BCA protein assay kit
- SDS-PAGE gels
- Transfer buffer
- PVDF membrane
- Blocking buffer (e.g., 5% non-fat dry milk or BSA in TBST)
- Primary antibodies (e.g., anti-p-Akt (Ser473), anti-Akt, anti-p-FOXO3a (Thr32), anti-FOXO3a, anti-Cyclin D1, anti- β -actin)
- HRP-conjugated secondary antibodies
- Chemiluminescent substrate
- Imaging system

Procedure:

- Seed cells and treat with **ETP-45658** (e.g., 10 μ M for 1-4 hours for U2OS cells) as described for other assays.[\[1\]](#)
- Lyse the cells with lysis buffer and quantify the protein concentration using a BCA assay.
- Denature equal amounts of protein by boiling in Laemmli sample buffer.
- Separate the proteins by SDS-PAGE and transfer them to a PVDF membrane.
- Block the membrane with blocking buffer for 1 hour at room temperature.
- Incubate the membrane with the primary antibody overnight at 4°C.
- Wash the membrane with TBST and incubate with the appropriate HRP-conjugated secondary antibody for 1 hour at room temperature.

- Wash the membrane again with TBST.
- Detect the protein bands using a chemiluminescent substrate and an imaging system.
- Densitometry analysis can be performed to quantify the protein expression levels relative to a loading control (e.g., β -actin).

Visualizations

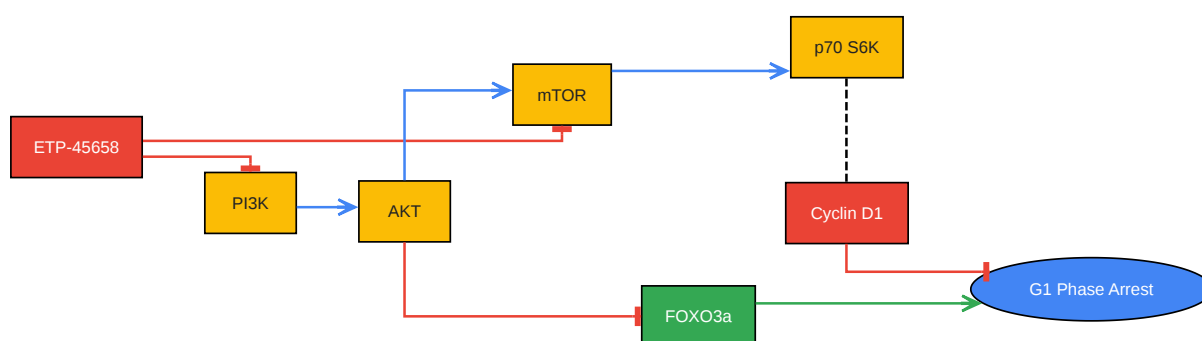

[Click to download full resolution via product page](#)

Caption: Signaling pathway of **ETP-45658** inducing G1 phase arrest.

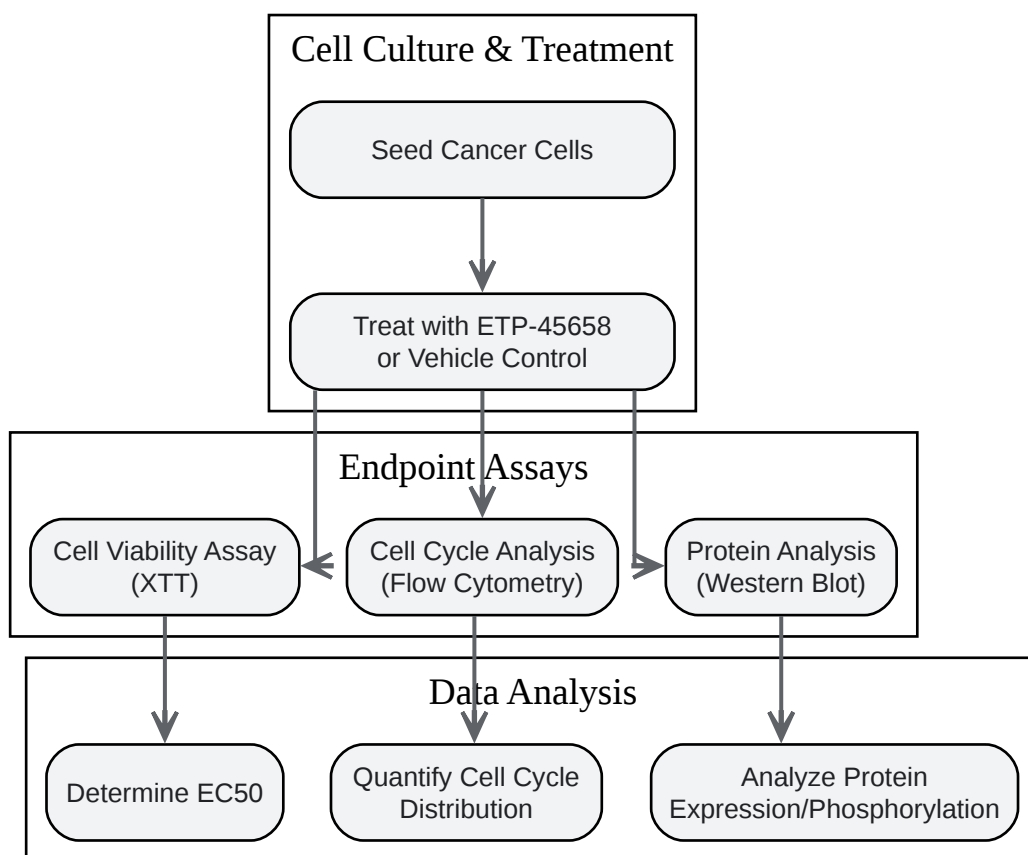

[Click to download full resolution via product page](#)

Caption: General experimental workflow for evaluating **ETP-45658**.

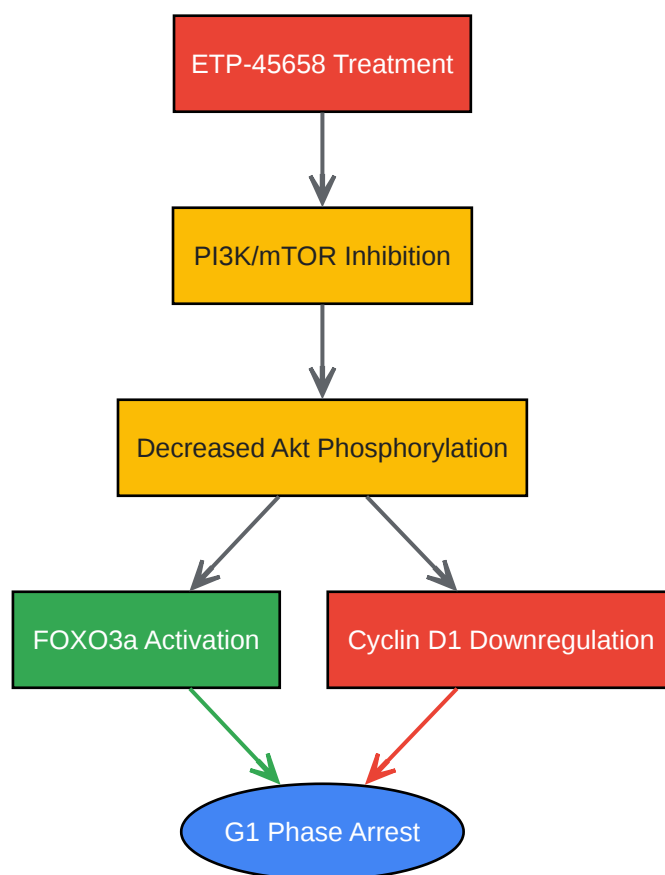

[Click to download full resolution via product page](#)

Caption: Logical flow from **ETP-45658** treatment to G1 arrest.

Need Custom Synthesis?

BenchChem offers custom synthesis for rare earth carbides and specific isotopic labeling.

Email: info@benchchem.com or [Request Quote Online](#).

References

- 1. medchemexpress.com [medchemexpress.com]
- 2. [ETP-45658 - Immunomart](http://ETP-45658-Immunomart.com) [immunomart.com]
- 3. Mechanism of anticancer effect of ETP-45658, a PI3K/AKT/mTOR pathway inhibitor on HT-29 Cells - PubMed [pubmed.ncbi.nlm.nih.gov]
- 4. researchgate.net [researchgate.net]

- [5. researchgate.net \[researchgate.net\]](#)
- To cite this document: BenchChem. [ETP-45658: Application Notes and Protocols for Inducing G1 Phase Arrest]. BenchChem, [2026]. [Online PDF]. Available at: [<https://www.benchchem.com/product/b15621646/docs#etp-45658-application-notes-and-protocols-for-inducing-g1-phase-arrest>]

Disclaimer & Data Validity:

The information provided in this document is for Research Use Only (RUO) and is strictly not intended for diagnostic or therapeutic procedures. While BenchChem strives to provide accurate protocols, we make no warranties, express or implied, regarding the fitness of this product for every specific experimental setup.

Technical Support: The protocols provided are for reference purposes. Unsure if this reagent suits your experiment?

Need Industrial/Bulk Grade? [Request Custom Synthesis Quote](#)

BenchChem

Our mission is to be the trusted global source of essential and advanced chemicals, empowering scientists and researchers to drive progress in science and industry.

Contact

Address: 3281 E Guasti Rd

Ontario, CA 91761, United States

Phone: (601) 213-4426

Email: info@benchchem.com

[Contact our Ph.D. Support Team for a compatibility check](#)