

Application Notes and Protocols for VH032-C7-COOH Reactions

Author: BenchChem Technical Support Team. **Date:** April 2026

Compound of Interest

Compound Name: VH032-C7-COOH

Cat. No.: B15621797

[Get Quote](#)

For Researchers, Scientists, and Drug Development Professionals

These application notes provide detailed protocols for the utilization of **VH032-C7-COOH** in the synthesis of Proteolysis Targeting Chimeras (PROTACs). **VH032-C7-COOH** is a functionalized ligand for the von Hippel-Lindau (VHL) E3 ubiquitin ligase, featuring a seven-carbon alkyl linker terminating in a carboxylic acid. This terminal carboxyl group serves as a versatile handle for conjugation to an amine-containing protein of interest (POI) ligand, forming a heterobifunctional PROTAC.

Overview of VH032-C7-COOH and its Role in PROTACs

VH032 is a potent inhibitor of the VHL interaction with Hypoxia-Inducible Factor 1 α (HIF-1 α).^[1] In the context of PROTACs, VH032 and its derivatives act as a recruitment moiety for the VHL E3 ligase. A PROTAC molecule consists of a VHL ligand (like **VH032-C7-COOH**), a linker, and a ligand for a target protein. By bringing the target protein in proximity to the VHL E3 ligase, the PROTAC facilitates the ubiquitination and subsequent proteasomal degradation of the target protein. The C7-COOH linker on VH032 provides a strategic exit vector for the attachment of various POI ligands through stable amide bond formation.

Key Applications

- Synthesis of VHL-based PROTACs: The primary application of **VH032-C7-COOH** is as a key building block in the modular synthesis of PROTACs to induce the degradation of a wide range of target proteins.
- Structure-Activity Relationship (SAR) Studies: The defined linker length allows for systematic studies on the impact of linker composition and length on ternary complex formation, degradation efficacy, and cell permeability.
- Development of Novel Therapeutics: By enabling the creation of PROTACs for previously "undruggable" targets, **VH032-C7-COOH** is a valuable tool in the development of new therapeutic agents for various diseases, including cancer.

Chemical Properties of VH032-C7-COOH

Property	Value
Molecular Formula	C31H44N4O6S
Molecular Weight	616.77 g/mol
Appearance	White to off-white solid
Solubility	Soluble in DMSO, DMF
Storage	Store at -20°C for long-term stability

Signaling Pathway of VHL-based PROTACs

The following diagram illustrates the mechanism of action of a PROTAC synthesized from **VH032-C7-COOH**.

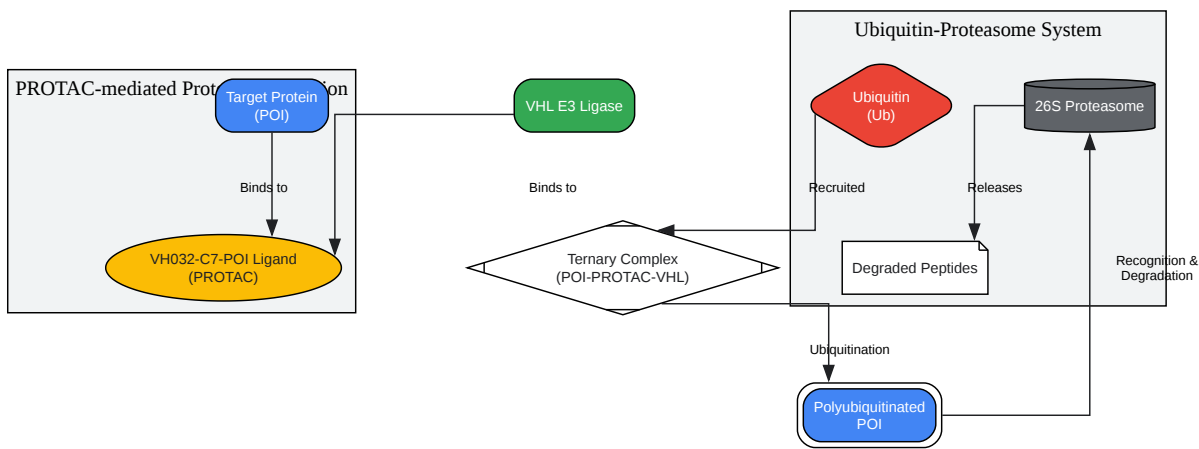

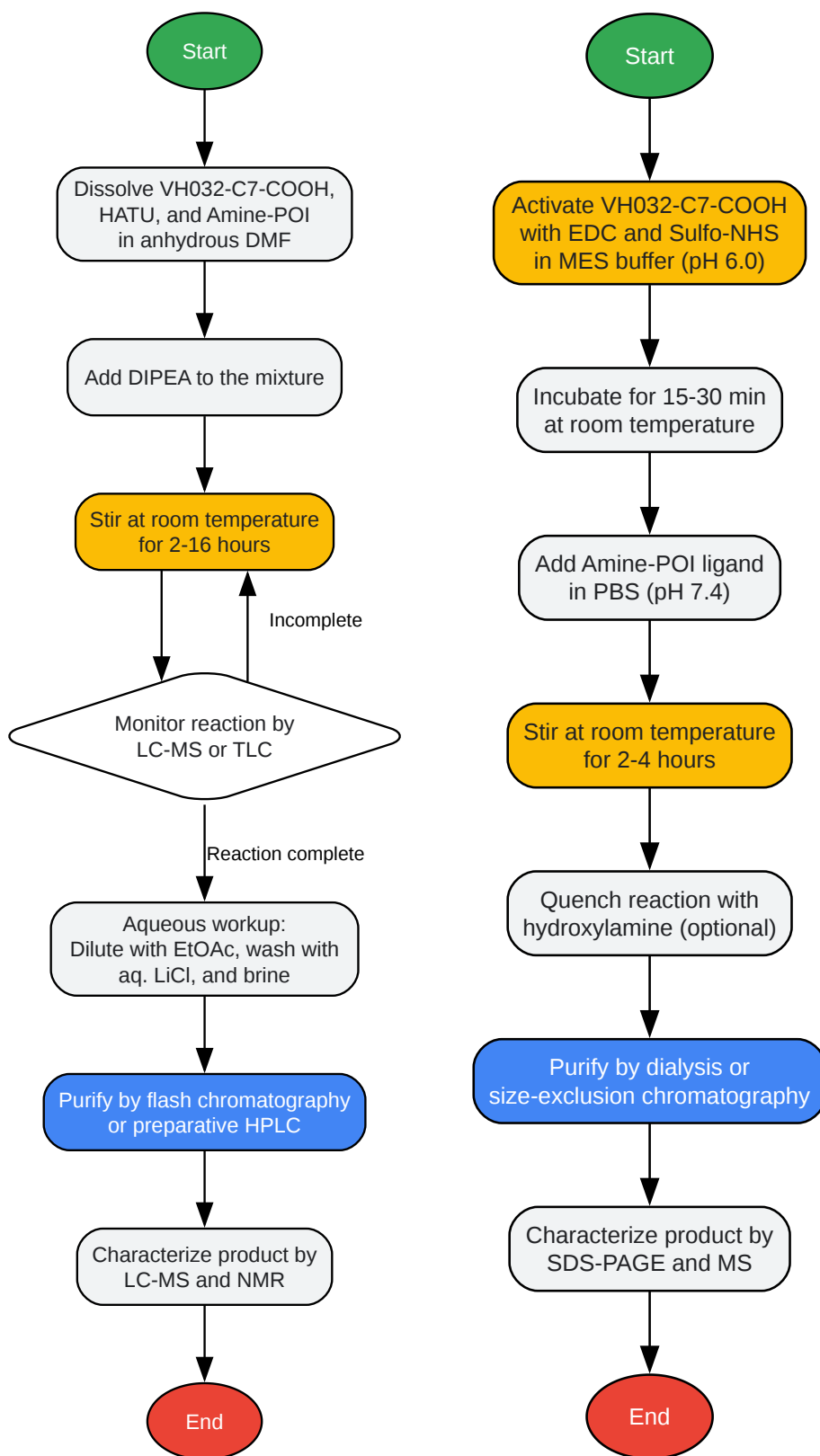

[Click to download full resolution via product page](#)

Need Custom Synthesis?

BenchChem offers custom synthesis for rare earth carbides and specific isotopic labeling.

Email: info@benchchem.com or [Request Quote Online](#).

References

- [1. medchemexpress.com \[medchemexpress.com\]](https://www.medchemexpress.com)
- To cite this document: BenchChem. [Application Notes and Protocols for VH032-C7-COOH Reactions]. BenchChem, [2026]. [Online PDF]. Available at: [\[https://www.benchchem.com/product/b15621797/docs#application-notes-and-protocols-for-vh032-c7-cooh-reactions\]](https://www.benchchem.com/product/b15621797/docs#application-notes-and-protocols-for-vh032-c7-cooh-reactions)

Disclaimer & Data Validity:

The information provided in this document is for Research Use Only (RUO) and is strictly not intended for diagnostic or therapeutic procedures. While BenchChem strives to provide accurate protocols, we make no warranties, express or implied, regarding the fitness of this product for every specific experimental setup.

Technical Support: The protocols provided are for reference purposes. Unsure if this reagent suits your experiment?

Need Industrial/Bulk Grade? [Request Custom Synthesis Quote](#)

BenchChem

Our mission is to be the trusted global source of essential and advanced chemicals, empowering scientists and researchers to drive progress in science and industry.

Contact

Address: 3281 E Guasti Rd

Ontario, CA 91761, United States

Phone: (601) 213-4426

Email: info@benchchem.com

Contact our Ph.D. Support Team for a compatibility check