

Application Notes and Protocols for In Vivo Administration of LLC0424

Author: BenchChem Technical Support Team. **Date:** April 2026

Compound of Interest

Compound Name: LLC0424
Cat. No.: B15621879

[Get Quote](#)

These application notes provide a comprehensive guide for researchers, scientists, and drug development professionals on the in vivo administration of **LLC0424**, a potent and selective PROTAC (Proteolysis Targeting Chimera) degrader of the nuclear receptor-binding SET domain-containing 2 (NSD2) protein.

Introduction

LLC0424 is a novel therapeutic agent that leverages PROTAC technology to induce the degradation of NSD2.^{[1][2]} NSD2 is a histone methyltransferase that plays a crucial role in gene expression and has been identified as a promising therapeutic target in various cancers.^[1] **LLC0424** works by forming a ternary complex between NSD2 and the E3 ubiquitin ligase cereblon (CRBN), leading to the ubiquitination and subsequent proteasomal degradation of NSD2.^{[3][4][5]} This targeted degradation results in the downregulation of H3K36me2, a key histone modification mediated by NSD2, and inhibits the growth of cancer cells with NSD2 mutations.^{[3][4]} These protocols are designed to guide researchers in conducting in vivo animal studies to evaluate the efficacy and pharmacodynamics of **LLC0424**.

Quantitative Data Summary

The following tables summarize the key in vitro and in vivo parameters of **LLC0424** based on published studies.

Table 1: In Vitro Activity of **LLC0424**

Parameter	Cell Line	Value	Reference
DC ₅₀ (NSD2 Degradation)	RPMI-8402	20 nM	[1][3][4]
D _{max} (NSD2 Degradation)	RPMI-8402	96%	[1][3][4]
IC ₅₀ (Cell Viability)	SEM	3.56 μM	[3][4]
IC ₅₀ (Cell Viability)	RPMI-8402	0.56 μM	[3][4]

Table 2: In Vivo Study Parameters for **LLC0424**

Parameter	Details	Reference
Animal Model	6–8 weeks old male CB17 severe combined immunodeficiency (SCID) mice	[3][5]
Tumor Model	Subcutaneous xenografts of SEM or 22RV1 cells	[3]
Formulation	LLC0424 dissolved in DMSO, then mixed with 40% 2-hydroxypropyl- β -cyclodextrin (HP β CD) in 5% dextrose in water (D5W)	[3]
Dosage	60 mg/kg	[3][4][5]
Route of Administration	Intravenous (IV) via retro-orbital vein or Intraperitoneal (IP)	[3][4][5]
Dosing Schedule	Once daily for 5 consecutive days	[3][4][5]
Pharmacodynamic Marker	NSD2 protein levels and H3K36me2 levels in tumor tissue	[3][4]

Experimental Protocols

Protocol 1: Formulation of LLC0424 for In Vivo Administration

This protocol describes the preparation of **LLC0424** for intravenous or intraperitoneal administration in mice.

Materials:

- **LLC0424**

- Dimethyl sulfoxide (DMSO)
- 2-hydroxypropyl- β -cyclodextrin (HP β CD)
- 5% dextrose in water (D5W)
- Sterile, pyrogen-free vials
- Sonicator
- Sterile filters (0.22 μ m)

Procedure:

- Prepare a 40% (w/v) solution of HP β CD in D5W. Gently warm and stir the solution to ensure complete dissolution. Allow the solution to cool to room temperature.
- Dissolve **LLC0424** in a minimal amount of DMSO to create a concentrated stock solution.
- Slowly add the **LLC0424**-DMSO stock solution to the 40% HP β CD solution. The final concentration of DMSO should be kept to a minimum, ideally below 5% of the total volume.
- Sonicate the resulting mixture until the **LLC0424** is completely dissolved and the solution is clear.
- Sterile-filter the final formulation using a 0.22 μ m syringe filter into a sterile, pyrogen-free vial.
- Prepare the formulation fresh before each administration to ensure stability and prevent precipitation.

Protocol 2: In Vivo Efficacy and Pharmacodynamics Study in a Xenograft Model

This protocol outlines the procedure for evaluating the anti-tumor efficacy and pharmacodynamic effects of **LLC0424** in a subcutaneous xenograft mouse model.

Animal Models:

- 6-8 week old male CB17 severe combined immunodeficiency (SCID) mice are a suitable model for establishing human tumor xenografts.[3]

Tumor Cell Implantation:

- Culture human cancer cell lines (e.g., SEM, RPMI-8402, or 22RV1) under standard conditions.
- Harvest the cells and resuspend them in a 1:1 mixture of serum-free medium and Matrigel. [3]
- Subcutaneously inject 10×10^6 cells into the dorsal flank of each mouse.[3]
- Monitor the mice regularly for tumor growth.

Treatment Administration:

- Once the tumors reach a palpable size (e.g., $\sim 200 \text{ mm}^3$), randomize the mice into treatment and vehicle control groups.[3]
- Administer **LLC0424** (formulated as described in Protocol 1) at a dose of 60 mg/kg via intravenous (retro-orbital) or intraperitoneal injection.[3][4][5]
- Administer the vehicle control (e.g., the same formulation without **LLC0424**) to the control group.
- Treat the mice once daily for five consecutive days.[3][4][5]

Monitoring and Endpoints:

- Measure tumor volume using digital calipers at least twice a week. Calculate tumor volume using the formula: $(\pi/6) \times L \times W^2$, where L is the longest diameter and W is the shortest diameter.[3]
- Monitor the body weight of the mice as an indicator of toxicity.
- At the end of the treatment period (e.g., on day 5), euthanize a subset of mice from each group to collect tumor tissue for pharmacodynamic analysis.[3][4]

- Process the harvested tumor tissues for Western blot analysis to determine the levels of NSD2 and H3K36me2.[3]
- Continue to monitor the remaining mice for tumor growth and survival.

Visualizations

Signaling Pathway of LLC0424

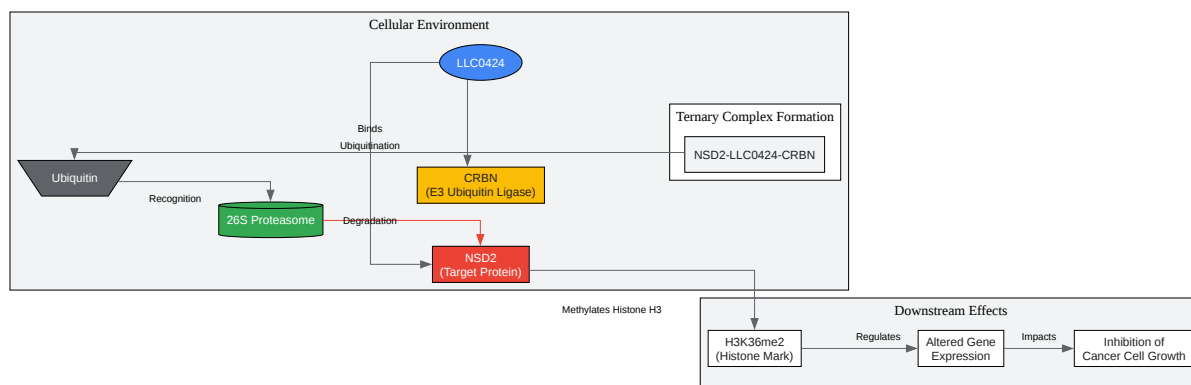

[Click to download full resolution via product page](#)

Caption: Mechanism of action of **LLC0424** as a PROTAC degrader of NSD2.

Experimental Workflow for In Vivo Studies

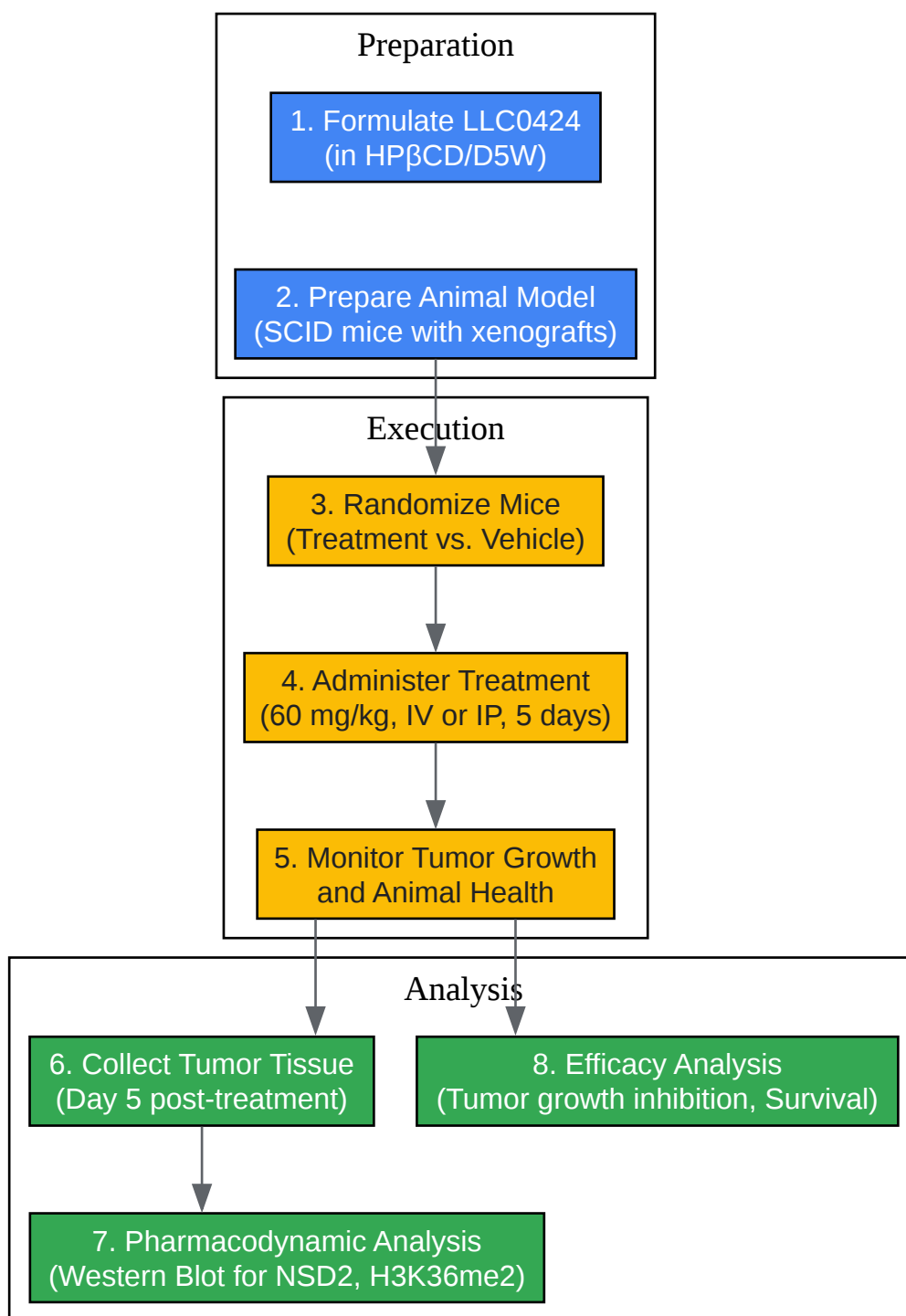

[Click to download full resolution via product page](#)

Caption: General experimental workflow for an in vivo study of **LLC0424**.

Need Custom Synthesis?

BenchChem offers custom synthesis for rare earth carbides and specific isotopic labeling.

Email: info@benchchem.com or [Request Quote Online](#).

References

- [1. researchgate.net \[researchgate.net\]](https://www.researchgate.net)
- [2. aacrjournals.org \[aacrjournals.org\]](https://www.aacrjournals.org)
- [3. Discovery of LLC0424 as a Potent and Selective in Vivo NSD2 PROTAC Degrader - PMC \[pmc.ncbi.nlm.nih.gov\]](https://pubmed.ncbi.nlm.nih.gov/36111111/)
- [4. pubs.acs.org \[pubs.acs.org\]](https://pubs.acs.org)
- [5. medchemexpress.com \[medchemexpress.com\]](https://www.medchemexpress.com)
- To cite this document: BenchChem. [Application Notes and Protocols for In Vivo Administration of LLC0424]. BenchChem, [2026]. [Online PDF]. Available at: [\[https://www.benchchem.com/product/b15621879/docs#application-notes-and-protocols-for-in-vivo-administration-of-llc0424\]](https://www.benchchem.com/product/b15621879/docs#application-notes-and-protocols-for-in-vivo-administration-of-llc0424)

Disclaimer & Data Validity:

The information provided in this document is for Research Use Only (RUO) and is strictly not intended for diagnostic or therapeutic procedures. While BenchChem strives to provide accurate protocols, we make no warranties, express or implied, regarding the fitness of this product for every specific experimental setup.

Technical Support: The protocols provided are for reference purposes. Unsure if this reagent suits your experiment?

Need Industrial/Bulk Grade? [Request Custom Synthesis Quote](#)

BenchChem

Our mission is to be the trusted global source of essential and advanced chemicals, empowering scientists and researchers to drive progress in science and industry.

Contact

Address: 3281 E Guasti Rd
Ontario, CA 91761, United States
Phone: (601) 213-4426
Email: info@benchchem.com

[Contact our Ph.D. Support Team for a compatibility check](#)