

# optimizing buffer conditions for dCeMM2 in vitro assays

**Author:** BenchChem Technical Support Team. **Date:** April 2026

## Compound of Interest

Compound Name: *dCeMM2*  
Cat. No.: *B15620477*

[Get Quote](#)

## dCeMM2 In Vitro Assays: Technical Support Center

This technical support center provides troubleshooting guidance and frequently asked questions (FAQs) for researchers utilizing **dCeMM2** in in vitro assays. The information is designed to help optimize experimental conditions and address common challenges.

### Frequently Asked Questions (FAQs)

Q1: What is **dCeMM2** and what is its mechanism of action?

A1: **dCeMM2** is a molecular glue degrader.<sup>[1][2]</sup> It functions by inducing the interaction between the CDK12-cyclin K complex and the CRL4B E3 ubiquitin ligase complex.<sup>[1][3]</sup> Specifically, **dCeMM2** facilitates the proximity of CDK12-cyclin K to DDB1, a component of the CRL4B ligase, leading to the ubiquitination and subsequent proteasomal degradation of cyclin K.<sup>[3][4]</sup>

Q2: What are the typical concentrations and treatment times for **dCeMM2** in cell-based assays?

A2: Effective concentrations and incubation times can be cell-line dependent. However, a common starting point is 2.5  $\mu\text{M}$  **dCeMM2** for 2 to 5 hours.[1][3] Some studies have used up to 10  $\mu\text{M}$  for a 1-hour treatment to observe interactions between CDK12 and DDB1 in HEK cells.[3][5] A time-course and dose-response experiment is recommended to determine the optimal conditions for your specific cell line.[6]

Q3: How should I prepare and store **dCeMM2** stock solutions?

A3: **dCeMM2** is soluble in DMSO up to 50 mM.[1] It is recommended to prepare a concentrated stock solution in DMSO, which can then be aliquoted and stored at  $-20^{\circ}\text{C}$  for up to one month or  $-80^{\circ}\text{C}$  for up to six months to avoid repeated freeze-thaw cycles.[3] For experiments, fresh dilutions should be made from the stock solution.

Q4: What are the key components of an in vitro assay buffer for studying **dCeMM2** activity?

A4: The optimal buffer composition can vary depending on the specific assay (e.g., ubiquitination assay, TR-FRET). However, common components include a buffering agent (like HEPES), salts (e.g., NaCl), a magnesium source ( $\text{MgCl}_2$ ), a reducing agent (like DTT or TCEP), and a non-ionic detergent (e.g., NP-40 or Tween-20) to prevent non-specific binding. Bovine Serum Albumin (BSA) is also frequently included.

## Troubleshooting Guides

### Problem 1: No or weak degradation of cyclin K observed.

Possible Cause	Suggestion
Suboptimal dCeMM2 Concentration	Perform a dose-response experiment to determine the optimal concentration for your cell line. <a href="#">[6]</a>
Insufficient Treatment Time	Conduct a time-course experiment to identify the optimal treatment duration. <a href="#">[6]</a>
Low Expression of Target Proteins	Confirm the expression levels of CDK12, cyclin K, and components of the CRL4B complex (DDB1, CUL4B) in your cell line via Western blot. <a href="#">[6]</a>
Poor Cell Health	Ensure cells are in the exponential growth phase and not overly confluent. <a href="#">[6]</a>
Serum Interference	If using high serum concentrations in your culture media, consider reducing it or performing a titration, as serum proteins may non-specifically bind to dCeMM2. <a href="#">[6]</a>
Degraded dCeMM2 Reagent	Ensure your dCeMM2 stock solution has been stored correctly and prepare fresh dilutions for each experiment. <a href="#">[6]</a>

## Problem 2: Inconsistent results between experiments.

Possible Cause	Suggestion
Variability in Cell Culture	Maintain consistent cell density, passage number, and overall culture conditions.[6]
Inconsistent Reagent Preparation	Prepare fresh dilutions of dCeMM2 from a validated stock solution for each experiment.[6]
Technical Variability	Ensure consistent protein loading for Western blotting and accurate cell seeding for other assays.[6]
Variable Serum Concentration	Use the same batch and concentration of serum for all related experiments to minimize variability.[6]

## Data Presentation: Buffer Conditions for In Vitro Assays

The following table summarizes buffer components used in relevant in vitro assays for studying molecular glue degraders like **dCeMM2**.

Assay Type	Buffer Component	Concentration	Reference
In Vitro Ubiquitination	HEPES, pH 7.5	50 mM	[1]
NaCl	100 mM	[1]	
MgCl <sub>2</sub>	10 mM	[1]	
DTT	2 mM	[1]	
ATP	5 mM	[1]	
In Vitro Ubiquitination (alternative)	HEPES, pH 8.0	50 mM	
NaCl	50 mM		
TCEP	1 mM		
MgATP	10 mM		
TR-FRET Assay (CDK12-DDB1 interaction)	HEPES, pH 7.5	50 mM	[7]
NaCl	300 mM	[7]	
TCEP	0.5 mM	[7]	
NP-40	0.1%	[7]	
BSA	0.1%	[7]	
TR-FRET Assay (general kinase)	HEPES, pH 7.5	50 mM	[8]
MgCl <sub>2</sub>	10 mM	[8]	
EGTA	1 mM	[8]	
Tween-20	0.01%	[8]	
DTT	2 mM	[8]	
BSA	0.05 mg/mL	[8]	

## Experimental Protocols

### Protocol: Western Blot for Cyclin K Degradation

- Cell Lysis:
  - After treating cells with **dCeMM2**, wash them with ice-cold PBS.
  - Lyse the cells in RIPA buffer supplemented with protease and phosphatase inhibitors.
  - Incubate on ice for 30 minutes with occasional vortexing.
  - Clarify the lysate by centrifuging at 14,000 rpm for 15 minutes at 4°C.[6]
- Protein Quantification:
  - Determine the protein concentration of the supernatant using a BCA assay or similar method.[6]
- Sample Preparation and SDS-PAGE:
  - Normalize protein concentrations across all samples.
  - Add Laemmli sample buffer and boil at 95°C for 5 minutes.
  - Load 20-30 µg of protein per lane on an SDS-PAGE gel.[6]
- Protein Transfer:
  - Transfer the separated proteins to a PVDF or nitrocellulose membrane.[6]
- Immunoblotting:
  - Block the membrane with 5% non-fat milk or BSA in TBST for 1 hour at room temperature. [6]
  - Incubate with a validated primary antibody against cyclin K overnight at 4°C.[6]

- Wash the membrane with TBST and incubate with an appropriate HRP-conjugated secondary antibody for 1 hour at room temperature.[6]
- Detection:
  - Wash the membrane with TBST.
  - Apply an ECL substrate and visualize the bands using a chemiluminescence imaging system.[6]
  - Probe for a loading control (e.g., GAPDH,  $\beta$ -actin) to ensure equal loading.[6]

## Visualizations

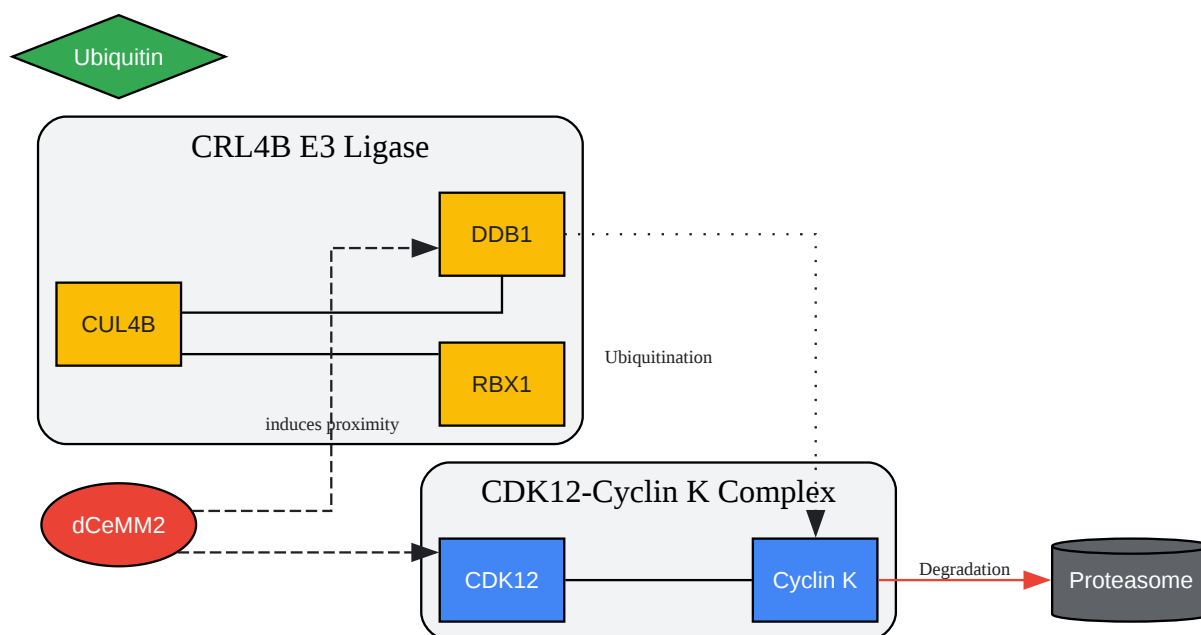

[Click to download full resolution via product page](#)

Caption: Mechanism of **dCeMM2**-induced Cyclin K degradation.

### Need Custom Synthesis?

BenchChem offers custom synthesis for rare earth carbides and specific isotopic labeling.

Email: [info@benchchem.com](mailto:info@benchchem.com) or [Request Quote Online](#).

## References

- 1. In vitro Di-ubiquitin Formation Assay and E3 Cooperation Assay - PMC [[pmc.ncbi.nlm.nih.gov](https://pubmed.ncbi.nlm.nih.gov/)]
- 2. [chemrxiv.org](https://chemrxiv.org/) [[chemrxiv.org](https://chemrxiv.org/)]
- 3. [wuxibiology.com](https://wuxibiology.com/) [[wuxibiology.com](https://wuxibiology.com/)]
- 4. [bpsbioscience.com](https://bpsbioscience.com/) [[bpsbioscience.com](https://bpsbioscience.com/)]
- 5. [medchemexpress.com](https://medchemexpress.com/) [[medchemexpress.com](https://medchemexpress.com/)]
- 6. [researchgate.net](https://researchgate.net/) [[researchgate.net](https://researchgate.net/)]
- 7. Discovery of a molecular glue promoting CDK12-DDB1 interaction to trigger cyclin K degradation - PMC [[pmc.ncbi.nlm.nih.gov](https://pubmed.ncbi.nlm.nih.gov/)]
- 8. AID 2061528 - TR-FRET Assay from US Patent US20250195475: "CDK2 INHIBITOR AND PREPARATION METHOD AND USE THEREOF" - PubChem [[pubchem.ncbi.nlm.nih.gov](https://pubchem.ncbi.nlm.nih.gov/)]
- To cite this document: BenchChem. [optimizing buffer conditions for dCeMM2 in vitro assays]. BenchChem, [2026]. [Online PDF]. Available at: [<https://www.benchchem.com/product/b15620477/docs#optimizing-buffer-conditions-for-dcemm2-in-vitro-assays>]

---

### Disclaimer & Data Validity:

The information provided in this document is for Research Use Only (RUO) and is strictly not intended for diagnostic or therapeutic procedures. While BenchChem strives to provide accurate protocols, we make no warranties, express or implied, regarding the fitness of this product for every specific experimental setup.

**Technical Support:** The protocols provided are for reference purposes. Unsure if this reagent suits your experiment?

**Need Industrial/Bulk Grade?** [Request Custom Synthesis Quote](#)

# BenchChem

Our mission is to be the trusted global source of essential and advanced chemicals, empowering scientists and researchers to drive progress in science and industry.

## Contact

Address: 3281 E Guasti Rd

Ontario, CA 91761, United States

Phone: (601) 213-4426

Email: [info@benchchem.com](mailto:info@benchchem.com)

[Contact our Ph.D. Support Team for a compatibility check](#)