

Visualizing the Subcellular Journey of YW3-56 Hydrochloride: Application Notes and Protocols

Author: BenchChem Technical Support Team. **Date:** April 2026

Compound of Interest

Compound Name: YW3-56 hydrochloride

Cat. No.: B15620870

[Get Quote](#)

For Researchers, Scientists, and Drug Development Professionals

These application notes provide detailed methodologies for visualizing and quantifying the subcellular distribution of **YW3-56 hydrochloride**, a potent peptidylarginine deiminase (PAD) inhibitor with significant anti-cancer properties. Understanding the localization of this compound within the cell is crucial for elucidating its mechanism of action and developing it as a therapeutic agent.

Introduction to YW3-56 Hydrochloride

YW3-56 hydrochloride is a small molecule inhibitor of PAD enzymes, particularly PAD2 and PAD4. These enzymes catalyze the conversion of arginine residues to citrulline on target proteins, a post-translational modification implicated in various diseases, including cancer. By inhibiting PADs, YW3-56 modulates gene expression and signaling pathways that control cell growth, proliferation, and survival. Notably, YW3-56 possesses intrinsic green fluorescence, a property that can be leveraged for direct visualization of its uptake and distribution within cells.

Key Applications

- Direct visualization of subcellular localization: Utilize the intrinsic fluorescence of YW3-56 to determine its accumulation in different cellular compartments, such as the nucleus and cytoplasm.
- Target engagement studies: Correlate the localization of YW3-56 with the location of its targets (PAD2 and PAD4) and downstream markers of its activity (e.g., histone citrullination).
- Pharmacodynamic assays: Quantify the effects of YW3-56 on downstream signaling pathways, such as the p53-SESN2-AKT-mTORC1 axis.
- Drug delivery and uptake analysis: Assess the efficiency of cellular uptake of YW3-56 under various experimental conditions.

Quantitative Data Summary

The following tables summarize the available quantitative data regarding the activity and effects of **YW3-56 hydrochloride**.

Table 1: Inhibitory Activity of **YW3-56 Hydrochloride**^[1]

Target Enzyme	IC50 (nM)
Human PAD4	1190
Mouse PAD4	2540
PAD1	1450
PAD2	6340
PAD3	53430

Table 2: Effect of YW3-56 on Downstream Signaling in U2OS Cells^[2]

Treatment	p-p70S6K (Thr389) Level	p53 Level	SESN2 Level	Histone H3 Citrullination
Control	Baseline	Baseline	Baseline	Baseline
YW3-56 (increasing concentration)	Decreased	Increased	Increased	Decreased
YW3-56 + p53 shRNA	Partially Restored	Decreased	Decreased	No significant change

Signaling Pathway

YW3-56 inhibits PAD4, preventing the citrullination of histones and other proteins. This leads to the activation of the tumor suppressor p53, which in turn upregulates the expression of Sestrin2 (SESN2). SESN2 then inhibits the mTORC1 signaling pathway, a key regulator of cell growth and proliferation, leading to decreased phosphorylation of its downstream effectors, p70S6K and 4E-BP1.

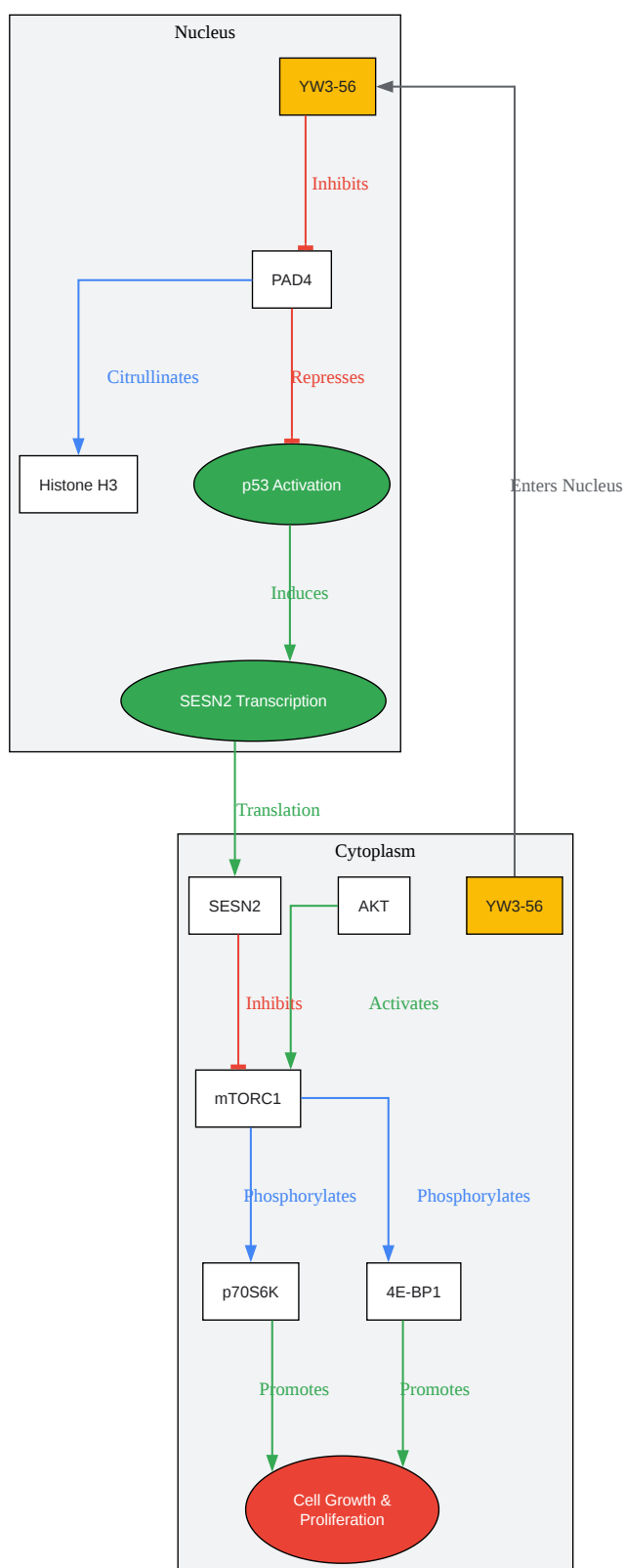

[Click to download full resolution via product page](#)

Caption: YW3-56 inhibits PAD4, leading to p53 activation, SESN2 induction, and subsequent suppression of the mTORC1 pathway.

Experimental Protocols

Protocol 1: Direct Visualization of YW3-56 Subcellular Localization by Fluorescence Microscopy

This protocol describes the use of fluorescence microscopy to visualize the intrinsic green fluorescence of YW3-56 in cultured cells.[3]

Materials:

- **YW3-56 hydrochloride**
- U2OS cells (or other cancer cell line of interest)
- Cell culture medium (e.g., DMEM with 10% FBS)
- Glass-bottom culture dishes or coverslips
- Phosphate-buffered saline (PBS)
- Formaldehyde (4% in PBS)
- DAPI (4',6-diamidino-2-phenylindole) solution
- Fluorescence microscope with appropriate filter sets

Note: The specific excitation and emission wavelengths for YW3-56 have not been reported in the literature. Based on its observed green fluorescence, a standard FITC or GFP filter set (Excitation: ~488 nm, Emission: ~520 nm) is a recommended starting point. Optimization may be required.

Procedure:

- **Cell Seeding:** Seed U2OS cells onto glass-bottom dishes or coverslips at a density that will result in 50-70% confluency at the time of imaging.

- YW3-56 Treatment: Prepare a stock solution of **YW3-56 hydrochloride** in a suitable solvent (e.g., DMSO or water). Dilute the stock solution in pre-warmed cell culture medium to the desired final concentration (e.g., 2.5 μM).^[3]
- Remove the existing medium from the cells and replace it with the YW3-56-containing medium.
- Incubate the cells for the desired time period (e.g., 8 hours).^[2]
- Cell Fixation:
 - Aspirate the YW3-56-containing medium.
 - Wash the cells twice with PBS.
 - Add 4% formaldehyde in PBS and incubate for 15 minutes at room temperature.
 - Wash the cells three times with PBS.
- Nuclear Staining:
 - Add DAPI solution to the cells and incubate for 5-10 minutes at room temperature, protected from light.
 - Wash the cells twice with PBS.
- Imaging:
 - Mount the coverslips onto microscope slides with an appropriate mounting medium or image the glass-bottom dishes directly.
 - Acquire images using a fluorescence microscope. Use the DAPI channel to visualize the nucleus and a green fluorescence channel (e.g., FITC/GFP) to visualize YW3-56.

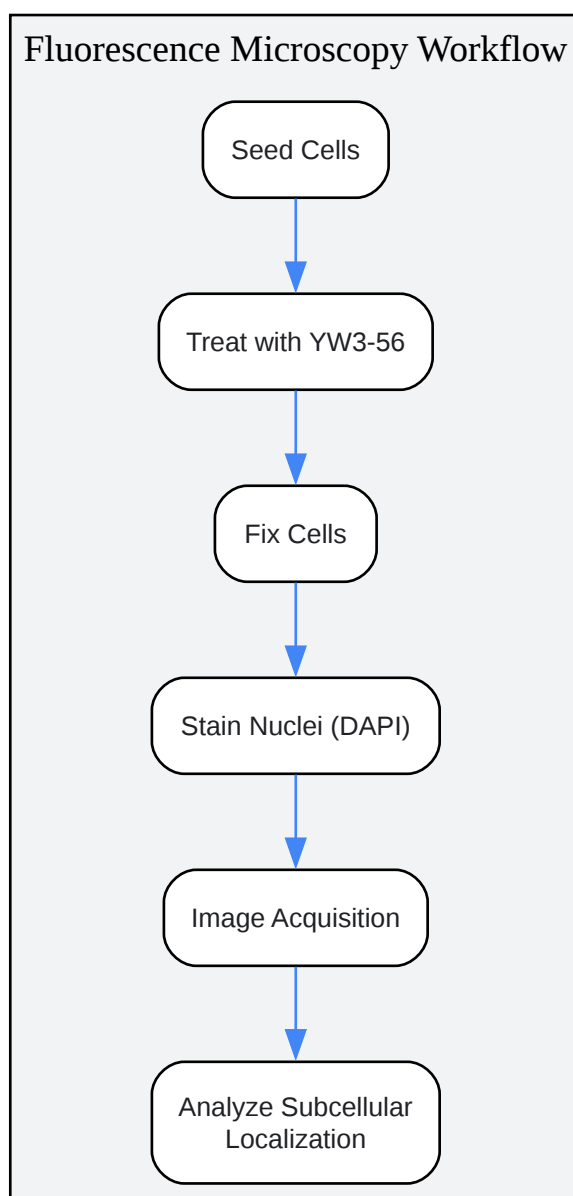

[Click to download full resolution via product page](#)

Caption: Experimental workflow for visualizing YW3-56 subcellular localization.

Protocol 2: Subcellular Fractionation and Western Blotting for Target Engagement

This protocol describes how to separate cellular components to quantify the levels of YW3-56's downstream effectors in the nucleus and cytoplasm.

Materials:

- Treated and untreated cells
- Subcellular fractionation kit (or buffers for differential centrifugation)
- Protease and phosphatase inhibitor cocktails
- BCA protein assay kit
- SDS-PAGE gels and running buffer
- Transfer buffer and PVDF membrane
- Blocking buffer (e.g., 5% non-fat milk or BSA in TBST)
- Primary antibodies (e.g., anti-p-p70S6K, anti-p70S6K, anti-Histone H3, anti-GAPDH)
- HRP-conjugated secondary antibodies
- Chemiluminescent substrate
- Imaging system for western blots

Procedure:

- Cell Lysis and Fractionation:
 - Harvest cells treated with YW3-56 and control cells.
 - Perform subcellular fractionation according to the manufacturer's protocol or a standard differential centrifugation method to separate nuclear and cytoplasmic fractions.
 - Add protease and phosphatase inhibitors to all buffers.
- Protein Quantification:
 - Determine the protein concentration of each fraction using a BCA assay.

- Western Blotting:
 - Normalize the protein amounts for each sample and prepare them for SDS-PAGE.
 - Separate the proteins by SDS-PAGE and transfer them to a PVDF membrane.
 - Block the membrane with blocking buffer for 1 hour at room temperature.
 - Incubate the membrane with primary antibodies overnight at 4°C. Use antibodies against phosphorylated and total forms of downstream targets (e.g., p-p70S6K and total p70S6K). Use Histone H3 as a nuclear marker and GAPDH as a cytoplasmic marker to verify the purity of the fractions.
 - Wash the membrane with TBST and incubate with HRP-conjugated secondary antibodies for 1 hour at room temperature.
 - Wash the membrane again and apply the chemiluminescent substrate.
 - Capture the image using an appropriate imaging system.
- Data Analysis:
 - Quantify the band intensities using image analysis software.
 - Normalize the levels of phosphorylated proteins to the total protein levels in each fraction.

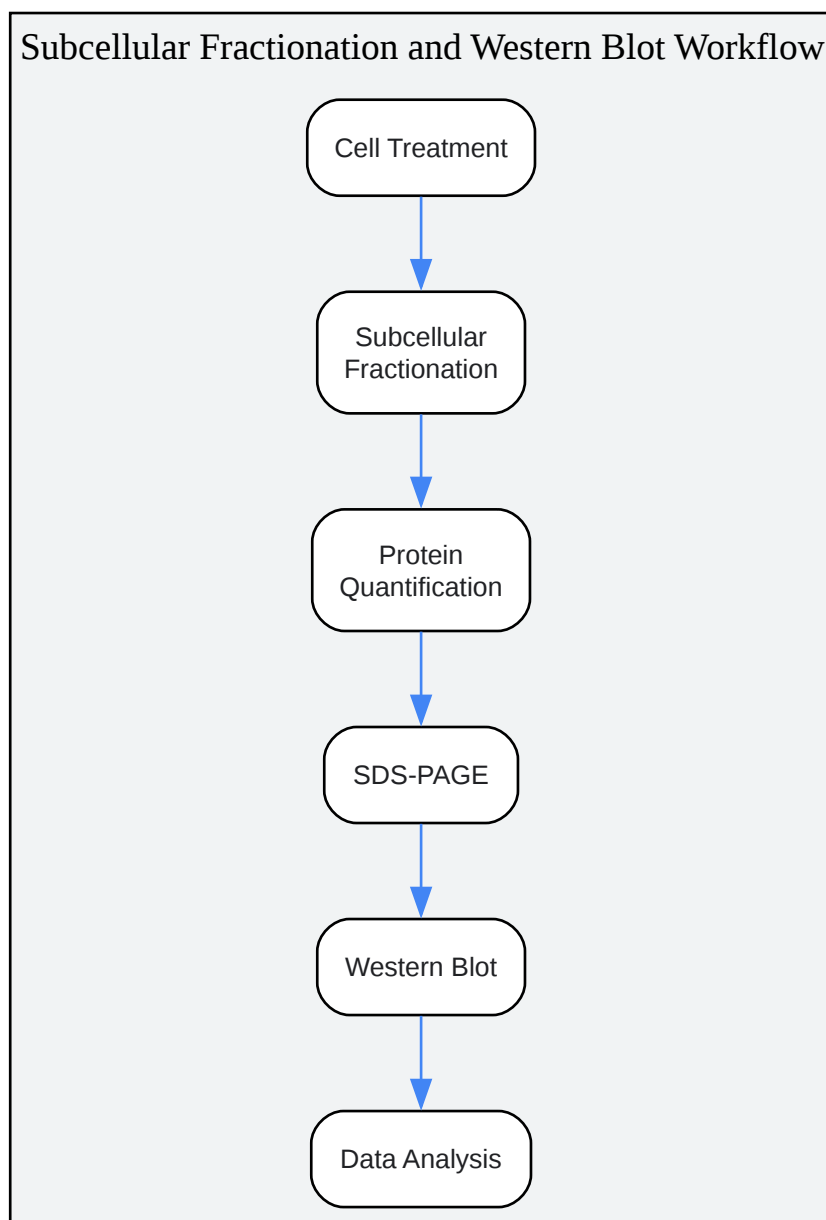

[Click to download full resolution via product page](#)

Caption: Workflow for analyzing target engagement in subcellular fractions.

Troubleshooting and Considerations

- Photobleaching: YW3-56's fluorescence may be susceptible to photobleaching. Minimize exposure time and use an anti-fade mounting medium.

- **Signal-to-Noise Ratio:** Optimize the concentration of YW3-56 and the imaging parameters to achieve a good signal-to-noise ratio.
- **Purity of Subcellular Fractions:** The purity of the nuclear and cytoplasmic fractions is critical for accurate western blot analysis. Always include fractionation controls (e.g., Histone H3 for nuclear, GAPDH for cytoplasmic).
- **Quantitative Analysis of Fluorescence:** For quantitative analysis of YW3-56 distribution, use image analysis software to measure the mean fluorescence intensity in the nucleus and cytoplasm. Express the localization as a ratio or percentage.

By employing these techniques, researchers can gain valuable insights into the subcellular distribution and mechanism of action of **YW3-56 hydrochloride**, facilitating its development as a targeted cancer therapeutic.

Need Custom Synthesis?

BenchChem offers custom synthesis for rare earth carbides and specific isotopic labeling.

Email: info@benchchem.com or [Request Quote Online](#).

References

- [1. Nuclear localization of peptidylarginine deiminase V and histone deimination in granulocytes - PubMed \[pubmed.ncbi.nlm.nih.gov\]](#)
- [2. Inhibition of phosphodiesterase 4D suppresses mTORC1 signaling and pancreatic cancer growth - PubMed \[pubmed.ncbi.nlm.nih.gov\]](#)
- [3. PAD4-dependent citrullination of nuclear translocation of GSK3 \$\beta\$ promotes colorectal cancer progression via the degradation of nuclear CDKN1A - PMC \[pmc.ncbi.nlm.nih.gov\]](#)
- To cite this document: BenchChem. [Visualizing the Subcellular Journey of YW3-56 Hydrochloride: Application Notes and Protocols]. BenchChem, [2026]. [Online PDF]. Available at: [<https://www.benchchem.com/product/b15620870/docs#visualizing-the-subcellular-journey-of-yw3-56-hydrochloride-application-notes-and-protocols>]

Disclaimer & Data Validity:

The information provided in this document is for Research Use Only (RUO) and is strictly not intended for diagnostic or therapeutic procedures. While BenchChem strives to provide accurate protocols, we make no warranties, express or implied, regarding the fitness of this product for every specific experimental setup.

Technical Support: The protocols provided are for reference purposes. Unsure if this reagent suits your experiment?

Need Industrial/Bulk Grade? [Request Custom Synthesis Quote](#)

BenchChem

Our mission is to be the trusted global source of essential and advanced chemicals, empowering scientists and researchers to drive progress in science and industry.

Contact

Address: 3281 E Guasti Rd
Ontario, CA 91761, United States
Phone: (601) 213-4426
Email: info@benchchem.com

[Contact our Ph.D. Support Team for a compatibility check](#)