

VAV1 Degradator-3 vs. VAV1 Small Molecule Inhibitors: A Comparative Guide

Author: BenchChem Technical Support Team. **Date:** April 2026

Compound of Interest

Compound Name: VAV1 degrader-3

Cat. No.: B15620411

[Get Quote](#)

In the landscape of therapeutic intervention targeting the VAV1 signaling pathway, two distinct strategies have emerged: targeted protein degradation and small molecule inhibition. This guide provides a detailed comparison of **VAV1 degrader-3** (MRT-6160), a first-in-class molecular glue degrader, and a representative VAV1 small molecule inhibitor, focusing on their mechanisms of action, performance data, and the experimental methodologies used for their evaluation. This objective analysis is intended to inform researchers, scientists, and drug development professionals on the key differences and potential advantages of each approach.

Mechanism of Action: A Tale of Two Strategies

VAV1 Small Molecule Inhibitors: These compounds typically function by binding to the catalytic domain of the VAV1 protein. This binding event competitively inhibits the interaction of VAV1 with its downstream effector, Rac1, a Rho family GTPase. By preventing this interaction, the guanine nucleotide exchange factor (GEF) activity of VAV1 is blocked, thereby inhibiting the conversion of Rac1-GDP to its active Rac1-GTP form and disrupting downstream signaling cascades.

VAV1 Degradator-3 (MRT-6160): In contrast, **VAV1 degrader-3** operates through a mechanism of induced proximity. As a molecular glue degrader, it facilitates the formation of a ternary

complex between the VAV1 protein and an E3 ubiquitin ligase, specifically Cereblon (CRBN). This induced proximity leads to the polyubiquitination of VAV1, marking it for degradation by the proteasome. The result is the complete removal of the VAV1 protein from the cell, a fundamentally different outcome than enzymatic inhibition.

Performance Data: A Quantitative Comparison

The following tables summarize the key quantitative data for **VAV1 degrader-3** and a representative VAV1 small molecule inhibitor.

Compound	Metric	Value	Cell Line/System
VAV1 Degradator-3 (MRT-6160)	DC ₅₀	7 nM	Not specified
VAV1 Small Molecule Inhibitor	IC ₅₀	61 nM	Biochemical Assay

Table 1: Potency Comparison. DC₅₀ represents the concentration required to degrade 50% of the target protein, while IC₅₀ is the concentration needed to inhibit 50% of the target's activity.

Compound	Effect	Assay	Details
VAV1 Degradar-3 (MRT-6160)	>90% VAV1 degradation	In vivo (human peripheral T and B cells)	Achieved at higher doses in a Phase 1 clinical study[1][2].
Up to 99% inhibition of IL-2, IFN- γ , and IL-17A secretion	Ex vivo (human whole blood-derived T cells)	Following T-cell receptor stimulation[1].	
Significant attenuation of IL-6 production	Ex vivo (human whole blood-derived B cells)	Following B-cell stimulation.	
Sustained suppression of CD69	Ex vivo (human whole blood)	T and B cell activation marker.	
VAV1 Small Molecule Inhibitor	Inhibition of VAV1-GEF dependent activation of RAC1	Biochemical Assay	Allosteric inhibition mechanism[3].

Table 2: In Vitro and In Vivo Efficacy.

Signaling Pathways and Mechanisms of Action

To visually represent the distinct mechanisms, the following diagrams illustrate the VAV1 signaling pathway and the modes of action for both the degrader and the inhibitor.

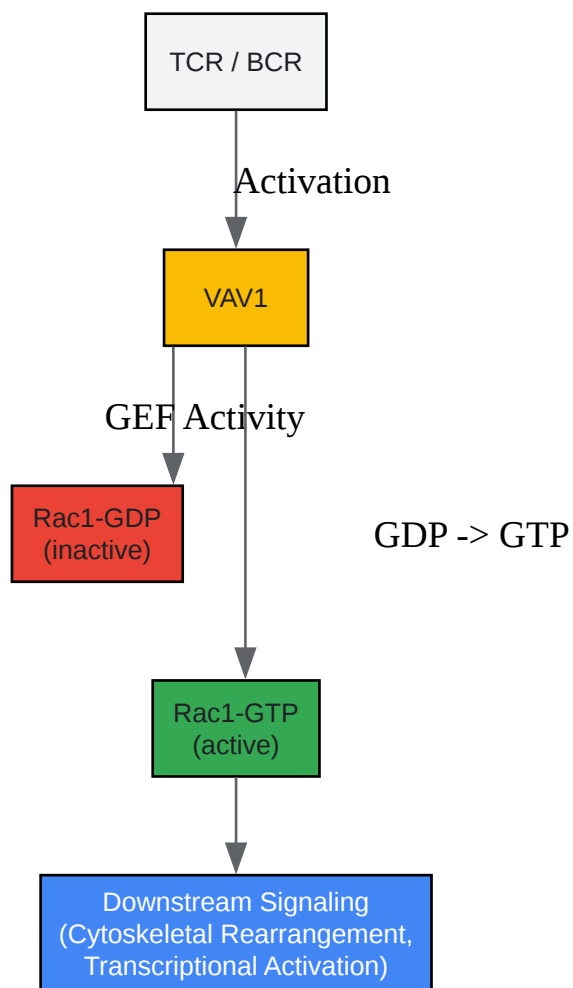

[Click to download full resolution via product page](#)

Caption: VAV1 Signaling Pathway.

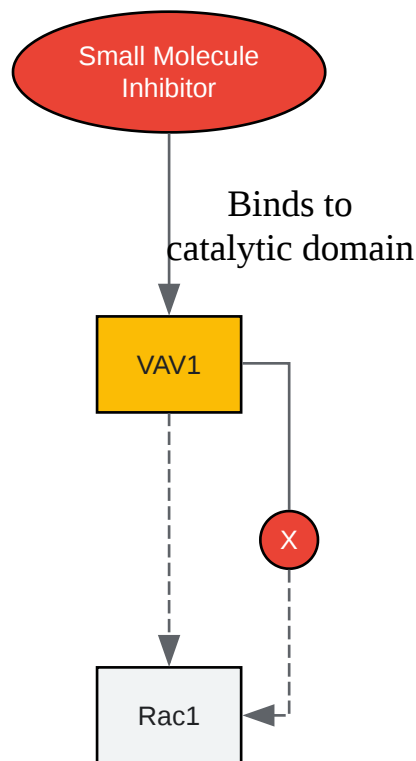

[Click to download full resolution via product page](#)

Caption: VAV1 Small Molecule Inhibitor Mechanism.

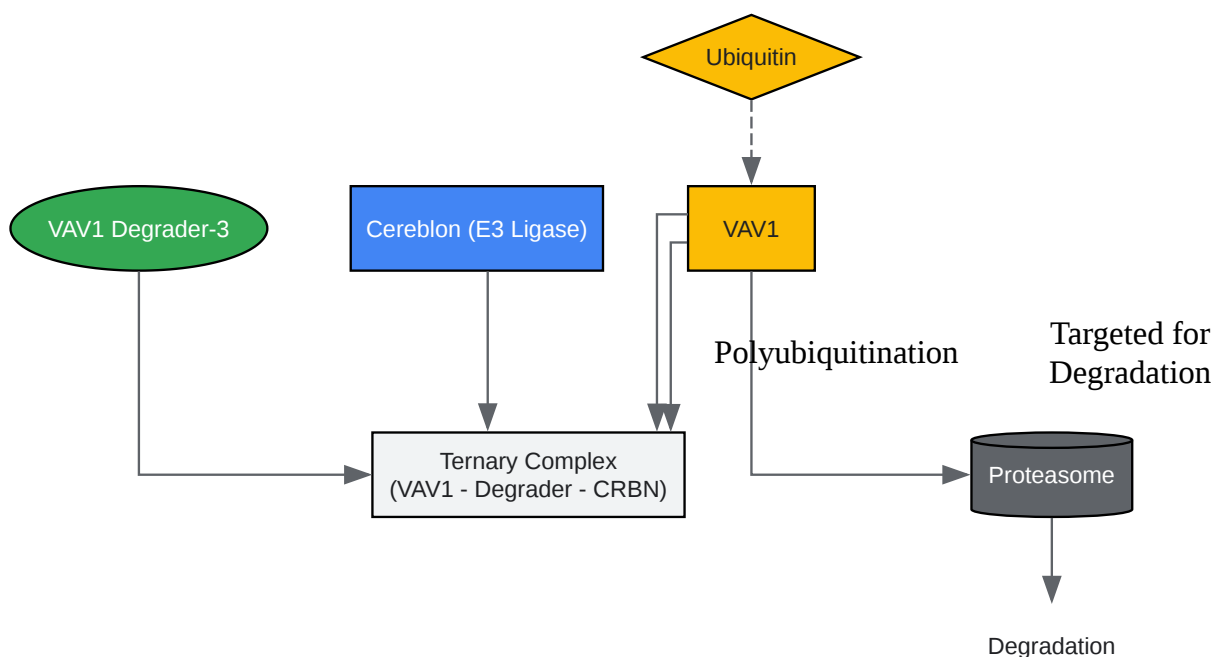

[Click to download full resolution via product page](#)

Need Custom Synthesis?

BenchChem offers custom synthesis for rare earth carbides and specific isotopic labeling.

Email: info@benchchem.com or [Request Quote Online](#).

References

- [1. firstwordpharma.com](https://www.firstwordpharma.com) [[firstwordpharma.com](https://www.firstwordpharma.com)]
- [2. seekingalpha.com](https://www.seekingalpha.com) [[seekingalpha.com](https://www.seekingalpha.com)]
- [3. fm19.chemistrycongresses.ch](https://www.fm19.chemistrycongresses.ch) [[fm19.chemistrycongresses.ch](https://www.fm19.chemistrycongresses.ch)]
- To cite this document: BenchChem. [VAV1 Degradar-3 vs. VAV1 Small Molecule Inhibitors: A Comparative Guide]. BenchChem, [2026]. [Online PDF]. Available at: [<https://www.benchchem.com/product/b15620411/docs#vav1-degrader-3-vs-vav1-small-molecule-inhibitors-a-comparative-guide>]

Disclaimer & Data Validity:

The information provided in this document is for Research Use Only (RUO) and is strictly not intended for diagnostic or therapeutic procedures. While BenchChem strives to provide accurate protocols, we make no warranties, express or implied, regarding the fitness of this product for every specific experimental setup.

Technical Support: The protocols provided are for reference purposes. Unsure if this reagent suits your experiment?

Need Industrial/Bulk Grade? [Request Custom Synthesis Quote](#)

BenchChem

Our mission is to be the trusted global source of essential and advanced chemicals, empowering scientists and researchers to drive progress in science and industry.

Contact

Address: 3281 E Guasti Rd

Ontario, CA 91761, United States

Phone: (601) 213-4426

Email: info@benchchem.com

[Contact our Ph.D. Support Team for a compatibility check](#)