

Technical Support Center: Refining dCeMM2 Treatment Times for Optimal Degradation

Author: BenchChem Technical Support Team. **Date:** April 2026

Compound of Interest

Compound Name: dCeMM2
Cat. No.: B15620477

[Get Quote](#)

This technical support center provides researchers, scientists, and drug development professionals with comprehensive guidance on utilizing **dCeMM2**, a molecular glue degrader targeting cyclin K. Here you will find troubleshooting guides, frequently asked questions (FAQs), detailed experimental protocols, and key data to optimize your experiments for efficient and specific protein degradation.

Frequently Asked Questions (FAQs)

Q1: What is **dCeMM2** and what is its mechanism of action?

A1: **dCeMM2** is a small molecule that functions as a molecular glue degrader. It specifically induces the degradation of cyclin K by promoting a new protein-protein interaction between the CDK12-cyclin K complex and the CRL4B (Cullin-4B-RING E3 ubiquitin ligase) complex. This induced proximity results in the ubiquitination of cyclin K, tagging it for degradation by the proteasome. This targeted degradation of cyclin K leads to the functional impairment of the CDK12/13 complex.^[1]

Q2: What are the primary research applications for **dCeMM2**?

A2: **dCeMM2** is a valuable research tool for studying the biological functions of cyclin K and the CDK12/13 complex. Its ability to induce rapid and specific degradation of cyclin K allows for the investigation of the downstream consequences of its depletion. This is particularly relevant in fields such as oncology and gene transcription regulation, as CDK12/13 is a key regulator of transcriptional elongation.

Q3: What is a recommended starting concentration and treatment time for **dCeMM2**?

A3: Based on published data, a starting concentration of 2.5 μ M in KBM7 cells has been shown to cause near-total degradation of cyclin K within 2 hours. However, the optimal concentration and time will vary depending on the cell line and experimental conditions. It is highly recommended to perform a dose-response and time-course experiment to determine the optimal conditions for your specific system.

Q4: Does **dCeMM2** have any known off-target effects?

A4: Proteomics studies have shown that **dCeMM2** leads to a pronounced destabilization of cyclin K.[2] It also causes a milder destabilization of the associated kinases, CDK12 and CDK13, particularly with prolonged incubation.[2][3] Furthermore, treatment with **dCeMM2** can induce a global downregulation of transcription, which is a phenotype consistent with the inhibition of CDK12/13.[2]

Q5: What are essential controls to include in my **dCeMM2** experiments?

A5: To ensure the validity of your results, the following controls are critical:

- Vehicle Control (e.g., DMSO): To establish a baseline for cyclin K levels.
- Proteasome Inhibitor (e.g., MG132, Carfilzomib): Pre-treatment with a proteasome inhibitor should rescue **dCeMM2**-induced cyclin K degradation, confirming a proteasome-dependent mechanism.[2]
- Inactive Analog Control (**dCeMM2X**): Using a structurally similar but inactive analog of **dCeMM2** helps to confirm that the observed degradation is specific to the intended mechanism of action.[2]

- Washout Experiment: To determine the reversibility of **dCeMM2**'s effect, cells can be treated with **dCeMM2** for a period, then washed and incubated in fresh media to observe the recovery of cyclin K levels.[2]

Troubleshooting Guide

Problem	Potential Cause	Suggested Solution
No or weak degradation of cyclin K observed.	Suboptimal dCeMM2 Concentration: The concentration of dCeMM2 may be too low for your specific cell line.	Perform a dose-response experiment (e.g., 0.1, 0.5, 1, 2.5, 5, 10 μ M) to determine the optimal concentration.
Insufficient Treatment Time: The incubation time may be too short to observe significant degradation.	Conduct a time-course experiment (e.g., 1, 2, 4, 8, 16, 24 hours) to identify the optimal treatment duration.	
Low Expression of Target or E3 Ligase Components: Your cell line may have low endogenous levels of cyclin K, CDK12, or components of the CRL4B complex (e.g., DDB1, CUL4B).	Verify the expression levels of these proteins in your cell line using Western blotting or qPCR. Consider using a different cell line with higher expression.	
Poor Cell Permeability: dCeMM2 may not be efficiently entering the cells.	Ensure proper solubilization of dCeMM2 in DMSO. If permeability is a persistent issue, consider alternative delivery methods if available for similar compounds.	
Inconsistent results between experiments.	Variability in Cell Culture Conditions: Differences in cell density, passage number, or serum concentration can affect cellular responses.	Maintain consistent cell culture practices. Use the same batch and concentration of serum for all related experiments.
Degradation of dCeMM2 Stock Solution: Repeated freeze-thaw cycles can lead to the degradation of the compound.	Aliquot the dCeMM2 stock solution and store it at -80°C . Prepare fresh dilutions for each experiment. ^[1]	
High background or non-specific bands on Western	Antibody Issues: The primary or secondary antibody may not	Use a validated antibody specific for cyclin K. Optimize

blot. be specific or used at an optimal concentration. the antibody concentrations and blocking conditions.

Insufficient Washing:
Inadequate washing steps can lead to high background. Increase the number and duration of washing steps with an appropriate buffer (e.g., TBST).

Data Presentation

Table 1: Recommended **dCeMM2** Treatment Parameters

Parameter	KBM7 Cells	HEK293T Cells	General Recommendation
Concentration Range	0.3 - 2.5 μ M	10 μ M (for interaction studies)	Start with a dose-response from 0.1 to 10 μ M.
Optimal Time for Degradation	0.5 - 8 hours (near-complete at 2h)[1]	1 hour (for interaction studies)	Perform a time-course from 1 to 24 hours.
EC50 (Viability, 3-day treatment)	~0.3 μ M[2]	Not reported	To be determined empirically.
DC50 (Degradation)	Not explicitly reported	Not reported	To be determined empirically.
Dmax (Maximal Degradation)	Near-total degradation	Not reported	To be determined empirically.

Experimental Protocols

Protocol 1: Cyclin K Degradation Assay by Western Blotting

This protocol details the steps to assess the degradation of endogenous cyclin K following **dCeMM2** treatment.

Materials:

- **dCeMM2**
- Cell line of interest
- Complete cell culture medium
- DMSO (vehicle control)
- Proteasome inhibitor (e.g., MG132 or Carfilzomib)
- Phosphate-buffered saline (PBS)
- RIPA lysis buffer (supplemented with protease and phosphatase inhibitors)
- BCA protein assay kit
- Laemmli sample buffer
- SDS-PAGE gels
- PVDF or nitrocellulose membranes
- Blocking buffer (e.g., 5% non-fat milk or BSA in TBST)
- Primary antibody against cyclin K
- Primary antibody against a loading control (e.g., GAPDH, β -actin)
- HRP-conjugated secondary antibody
- Enhanced chemiluminescence (ECL) substrate
- Chemiluminescence imaging system

Procedure:

- Cell Seeding: Seed cells in a 6-well plate at a density that allows them to reach 70-80% confluency on the day of treatment.
- Treatment:
 - For dose-response: Treat cells with a range of **dCeMM2** concentrations (e.g., 0.1, 0.5, 1, 2.5, 5, 10 μM) and a vehicle control (DMSO) for a fixed time (e.g., 4 hours).
 - For time-course: Treat cells with a fixed concentration of **dCeMM2** (e.g., 2.5 μM) for different durations (e.g., 1, 2, 4, 8, 24 hours).
 - For proteasome inhibitor control: Pre-treat cells with a proteasome inhibitor (e.g., 1 μM MG132) for 1-2 hours before adding **dCeMM2**.
- Cell Lysis:
 - After treatment, wash the cells twice with ice-cold PBS.
 - Add an appropriate volume of ice-cold RIPA buffer to each well and scrape the cells.
 - Incubate the lysate on ice for 30 minutes, with occasional vortexing.
 - Centrifuge the lysate at 14,000 rpm for 15 minutes at 4°C to pellet cell debris.
 - Transfer the supernatant to a new tube.
- Protein Quantification: Determine the protein concentration of each lysate using a BCA assay.
- Sample Preparation and SDS-PAGE:
 - Normalize the protein concentration of all samples.
 - Add Laemmli sample buffer and boil at 95°C for 5 minutes.
 - Load equal amounts of protein (e.g., 20 μg) per lane onto an SDS-PAGE gel and run the gel.

- Western Blotting:
 - Transfer the proteins to a PVDF or nitrocellulose membrane.
 - Block the membrane with blocking buffer for 1 hour at room temperature.
 - Incubate the membrane with the primary antibody against cyclin K overnight at 4°C.
 - Wash the membrane three times with TBST.
 - Incubate with the HRP-conjugated secondary antibody for 1 hour at room temperature.
 - Wash the membrane three times with TBST.
- Detection:
 - Add ECL substrate to the membrane and visualize the bands using a chemiluminescence imaging system.
 - Strip and re-probe the membrane with an antibody against a loading control to ensure equal protein loading.

Protocol 2: Cell Viability/Cytotoxicity Assay (MTT Assay)

This protocol provides a method to assess the effect of **dCeMM2**-induced cyclin K degradation on cell viability.

Materials:

- **dCeMM2**
- Cell line of interest
- Complete cell culture medium
- DMSO
- 96-well plates

- MTT (3-(4,5-dimethylthiazol-2-yl)-2,5-diphenyltetrazolium bromide) solution (5 mg/mL in PBS)
- Solubilization solution (e.g., DMSO or 0.01 M HCl in 10% SDS)
- Microplate reader

Procedure:

- Cell Seeding: Seed cells into a 96-well plate at a pre-determined optimal density and allow them to attach overnight.
- Compound Treatment:
 - Prepare serial dilutions of **dCeMM2** in culture medium.
 - Remove the old medium from the wells and add 100 μ L of the medium containing the various concentrations of **dCeMM2**.
 - Include a vehicle control (DMSO) and a positive control for cytotoxicity (e.g., staurosporine).
- Incubation: Incubate the plate for the desired treatment period (e.g., 72 hours).
- MTT Incubation:
 - Add 10 μ L of MTT solution to each well.
 - Incubate the plate for 2-4 hours at 37°C until a purple precipitate is visible.
- Formazan Solubilization:
 - Carefully aspirate the medium containing MTT.
 - Add 100 μ L of solubilization solution to each well.
 - Place the plate on an orbital shaker for 15 minutes to ensure complete dissolution of the formazan crystals.

- Data Acquisition: Measure the absorbance at 570 nm using a microplate reader.
- Data Analysis: Plot the cell viability against the **dCeMM2** concentration to determine the EC50 value.

Visualizations

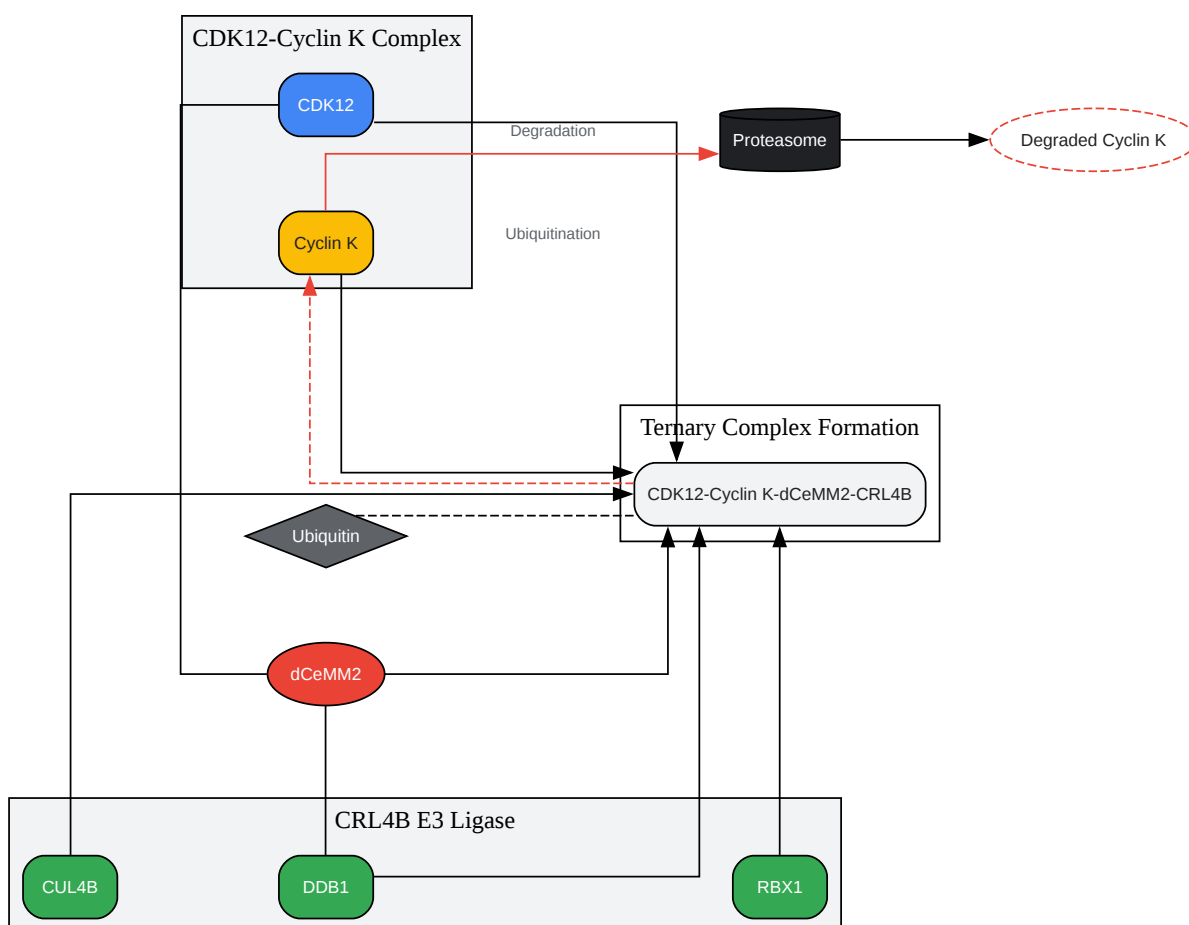

[Click to download full resolution via product page](#)

Caption: Mechanism of action of **dCeMM2**.

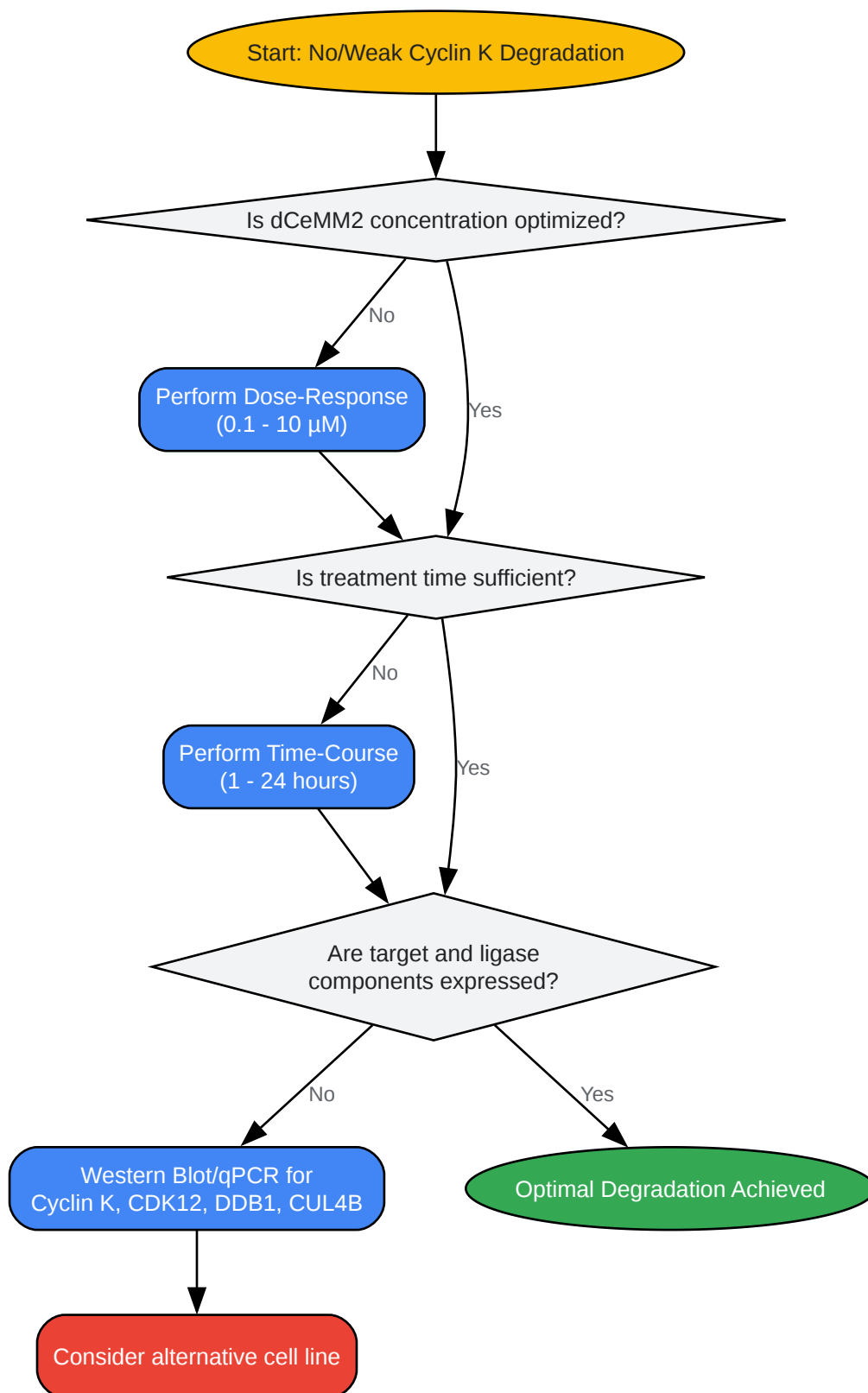

[Click to download full resolution via product page](#)

Caption: Troubleshooting workflow for suboptimal degradation.

Need Custom Synthesis?

BenchChem offers custom synthesis for rare earth carbides and specific isotopic labeling.

Email: info@benchchem.com or [Request Quote Online](#).

References

- [1. medchemexpress.com \[medchemexpress.com\]](https://www.medchemexpress.com)
- [2. Rational discovery of molecular glue degraders via scalable chemical profiling - PMC \[pmc.ncbi.nlm.nih.gov\]](https://pubmed.ncbi.nlm.nih.gov/)
- [3. benchchem.com \[benchchem.com\]](https://www.benchchem.com)
- To cite this document: BenchChem. [Technical Support Center: Refining dCeMM2 Treatment Times for Optimal Degradation]. BenchChem, [2026]. [Online PDF]. Available at: [<https://www.benchchem.com/product/b15620477/docs#technical-support-center-refining-dcemm2-treatment-times-for-optimal-degradation>]

Disclaimer & Data Validity:

The information provided in this document is for Research Use Only (RUO) and is strictly not intended for diagnostic or therapeutic procedures. While BenchChem strives to provide accurate protocols, we make no warranties, express or implied, regarding the fitness of this product for every specific experimental setup.

Technical Support: The protocols provided are for reference purposes. Unsure if this reagent suits your experiment?

Need Industrial/Bulk Grade? [Request Custom Synthesis Quote](#)

BenchChem

Our mission is to be the trusted global source of essential and advanced chemicals, empowering scientists and researchers to drive progress in science and industry.

Contact

Address: 3281 E Guasti Rd

Ontario, CA 91761, United States

Phone: (601) 213-4426

Email: info@benchchem.com

[Contact our Ph.D. Support Team for a compatibility check](#)