

# Technical Support Center: Lsd1-IN-34 In Vivo Delivery

**Author:** BenchChem Technical Support Team. **Date:** April 2026

## Compound of Interest

Compound Name: Lsd1-IN-34

Cat. No.: B15620275

[Get Quote](#)

Welcome to the technical support center for **Lsd1-IN-34**. This resource is designed to assist researchers, scientists, and drug development professionals in troubleshooting the in vivo delivery of this potent and selective LSD1 inhibitor. The following troubleshooting guides and frequently asked questions (FAQs) address common challenges encountered during preclinical experiments.

## Frequently Asked Questions (FAQs)

### Q1: What are the recommended vehicles for in vivo delivery of Lsd1-IN-34?

A1: The choice of vehicle for **Lsd1-IN-34** is critical and depends on the route of administration and the physicochemical properties of the compound, which is presumed to have low aqueous solubility. For initial in vivo studies, especially in rodent models, a suspension is often the most practical formulation.

Recommended Starting Vehicles for Oral (PO) and Intraperitoneal (IP) Administration:

Vehicle Composition	Suitability	Key Considerations
0.5% (w/v) Methylcellulose (MC) in water	Good	Forms a stable suspension for many poorly soluble compounds.
0.5% (w/v) Carboxymethylcellulose (CMC) in water	Good	Similar to methylcellulose, provides a viscous medium to keep the compound suspended.[1]
0.5% MC with 0.1-0.2% Tween® 80 in water	Better	The surfactant helps to wet the compound, improving suspension homogeneity.[2][3]
10% DMSO, 40% PEG400, 50% Saline	For difficult compounds	Use with caution due to potential toxicity of DMSO and PEG400.[1] Should be justified by poor performance of simpler vehicles.
Corn oil or other lipid-based vehicles	Alternative	Suitable for highly lipophilic compounds and may enhance oral absorption.[4]

Note: Always test the physical and chemical stability of your formulation before in vivo administration. A well-formulated suspension should be easily resuspendable and not settle too quickly.

## Q2: I am observing inconsistent results in my in vivo efficacy study. What could be the cause?

A2: Inconsistent results with **Lsd1-IN-34** can stem from several factors related to its formulation and administration.

Troubleshooting Inconsistent In Vivo Efficacy:

Potential Cause	Recommended Action
Poor Formulation Homogeneity	Ensure the suspension is uniformly mixed before each animal is dosed. Use a vortex mixer or stir plate. Prepare fresh formulations regularly to avoid degradation or changes in suspension properties.[3]
Inaccurate Dosing	Calibrate all dosing equipment (e.g., gavage needles, syringes) regularly. Ensure the volume administered is accurate for each animal's body weight.
Compound Instability	Lsd1-IN-34 may be unstable in certain vehicles or under specific storage conditions. Assess the stability of your formulation over the duration of your experiment.[5][6]
Low Bioavailability	The compound may be poorly absorbed. Consider particle size reduction (micronization) to increase the surface area for dissolution.[3] For oral administration, food effects can alter absorption; ensure consistent fasting or feeding schedules.
Rapid Metabolism	The compound may be rapidly cleared from circulation. Consider pharmacokinetic studies to determine the compound's half-life and optimize the dosing schedule.

### Q3: My animals are showing signs of toxicity. How can I determine if it's related to Lsd1-IN-34 or the vehicle?

A3: It is crucial to differentiate between compound-related toxicity and vehicle-related toxicity.

Deconvoluting Toxicity:

- Vehicle Control Group: Always include a group of animals that receives only the vehicle. This is the most critical control for assessing the tolerability of your formulation.[1]

- Dose Reduction: The most direct way to assess compound-specific toxicity is to lower the dose of **Lsd1-IN-34**.[\[7\]](#)
- Monitor Clinical Signs: Carefully observe all groups for signs of toxicity, such as weight loss, changes in behavior, or ruffled fur. Record these observations systematically.[\[2\]](#)
- Alternative Vehicles: Some vehicles, particularly those containing high percentages of organic solvents like DMSO or PEG, can cause local irritation or systemic toxicity.[\[1\]](#) If toxicity is observed in the vehicle group, a less harsh vehicle should be selected.

## Q4: How can I confirm target engagement of **Lsd1-IN-34** in my in vivo model?

A4: Confirming that **Lsd1-IN-34** is inhibiting its target, LSD1, in vivo is essential for interpreting efficacy data.

Methods for Target Engagement:

- Pharmacodynamic (PD) Biomarkers: Measure the levels of histone marks that are regulated by LSD1. Inhibition of LSD1 is expected to lead to an increase in H3K4me1/2 and H3K9me1/2 levels in tumor or surrogate tissues.[\[8\]](#)[\[9\]](#)[\[10\]](#)
- Gene Expression Analysis: Analyze the expression of LSD1 target genes. Inhibition of LSD1 can lead to the reactivation of silenced genes.[\[11\]](#)
- Western Blotting or Immunohistochemistry (IHC): Collect tissue samples at various time points after dosing and analyze the levels of relevant histone marks.[\[2\]](#)

## Experimental Protocols

### Protocol 1: Preparation of an Oral Suspension of **Lsd1-IN-34**

This protocol describes the preparation of a 10 mg/mL suspension of **Lsd1-IN-34** in 0.5% Methylcellulose with 0.1% Tween® 80.

Materials:

- **Lsd1-IN-34** powder
- Methylcellulose (viscosity ~400 cP)
- Tween® 80 (Polysorbate 80)
- Sterile water for injection
- Sterile glass vials
- Magnetic stir bar and stir plate or overhead stirrer

Procedure:

- Prepare the Vehicle:
  - In a sterile beaker, add approximately half of the final required volume of sterile water.
  - While stirring, slowly add the methylcellulose powder to create a vortex and prevent clumping.
  - Heat the mixture to ~60-70°C while stirring until the methylcellulose is fully dispersed.
  - Add the Tween® 80 and mix until dissolved.
  - Add the remaining volume of cold sterile water and continue to stir until a clear, uniform, and viscous solution is formed.
  - Allow the solution to cool to room temperature.
- Prepare the **Lsd1-IN-34** Suspension:
  - Weigh the required amount of **Lsd1-IN-34** powder.
  - To improve wetting, create a paste by triturating the **Lsd1-IN-34** powder with a small amount of the prepared vehicle using a mortar and pestle.
  - Gradually add the paste to the bulk of the vehicle in a sterile vial with a magnetic stir bar.

- Rinse the mortar and pestle with the remaining vehicle to ensure the complete transfer of the compound.
- Stir the final suspension for at least 30 minutes to ensure homogeneity.
- Storage and Administration:
  - Store the suspension at 2-8°C, protected from light.
  - Before each administration, bring the suspension to room temperature and vortex thoroughly to ensure uniform resuspension.

## Protocol 2: In Vivo Efficacy Study in a Xenograft Model

This protocol outlines a general procedure for evaluating the anti-tumor efficacy of **Lsd1-IN-34** in a subcutaneous xenograft mouse model.

Materials and Methods:

- Animal Model: Use appropriate immunocompromised mice (e.g., 6-8 week old female athymic nude mice).
- Tumor Cell Implantation:
  - Culture cancer cells of interest under standard conditions.
  - Harvest cells during the logarithmic growth phase and resuspend them in sterile, serum-free medium or PBS.
  - Subcutaneously inject  $1 \times 10^6$  to  $5 \times 10^6$  cells in a volume of 100-200  $\mu$ L into the flank of each mouse.<sup>[2]</sup>
- Tumor Growth and Randomization:
  - Monitor tumor growth every 2-3 days using calipers. Calculate tumor volume using the formula:  $(\text{Length} \times \text{Width}^2)/2$ .<sup>[2]</sup>

- When tumors reach a mean volume of 100-150 mm<sup>3</sup>, randomize the mice into treatment and control groups.
- Drug Administration:
  - Administer **Lsd1-IN-34** (prepared as in Protocol 1) and vehicle control according to the planned schedule (e.g., once daily) and route (e.g., oral gavage).[2]
- Monitoring:
  - Measure tumor volumes and body weights 2-3 times per week. Body weight is a key indicator of toxicity.[2]
- Endpoint and Tissue Collection:
  - At the end of the study (based on tumor size limits or a predetermined time point), euthanize the animals.
  - Collect tumors for pharmacodynamic analysis (e.g., Western blot, IHC for H3K4me2).

## Visualizations

### Signaling Pathways and Experimental Workflows

The following diagrams illustrate key signaling pathways involving LSD1 and a typical workflow for in vivo studies.

LSD1-Regulated Signaling Pathways

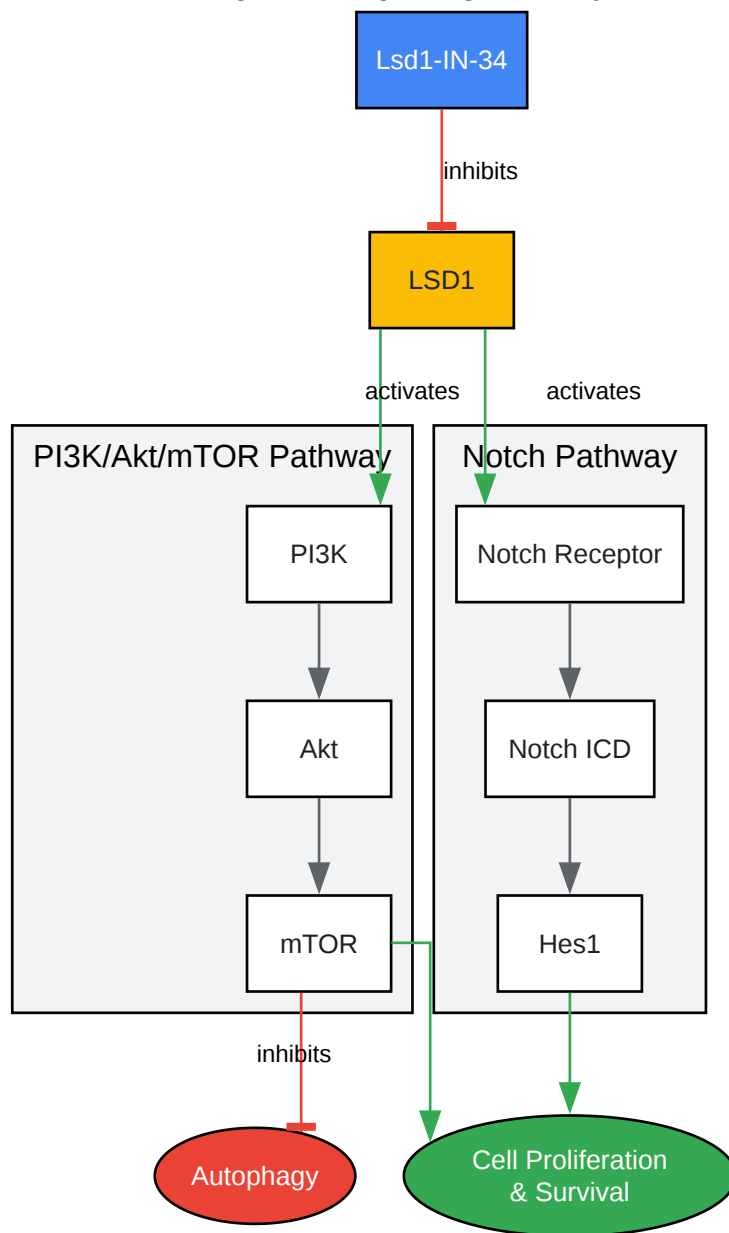

[Click to download full resolution via product page](#)

Caption: LSD1 activates the PI3K/Akt/mTOR and Notch signaling pathways.[12][13][14]

## In Vivo Efficacy Study Workflow

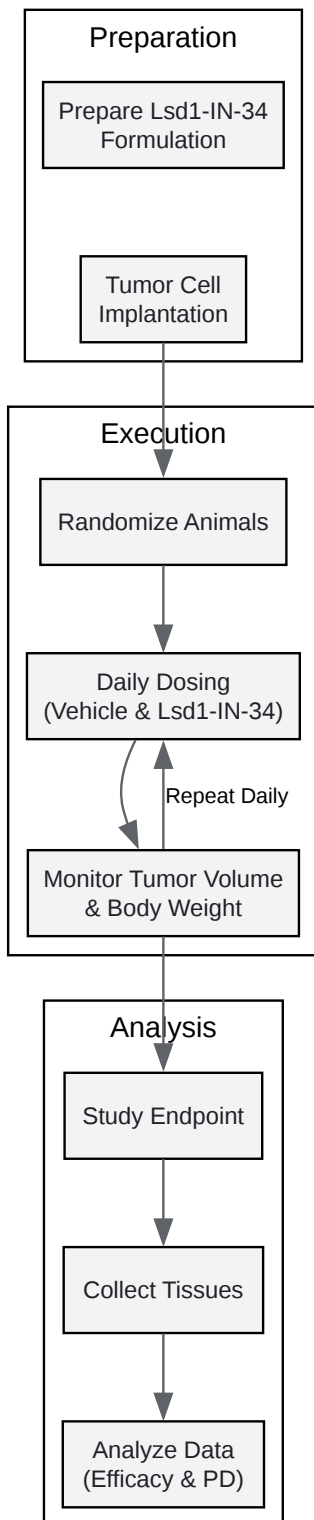

[Click to download full resolution via product page](#)

Caption: Workflow for a typical in vivo xenograft study.[2]

## Troubleshooting Logic for Poor Efficacy

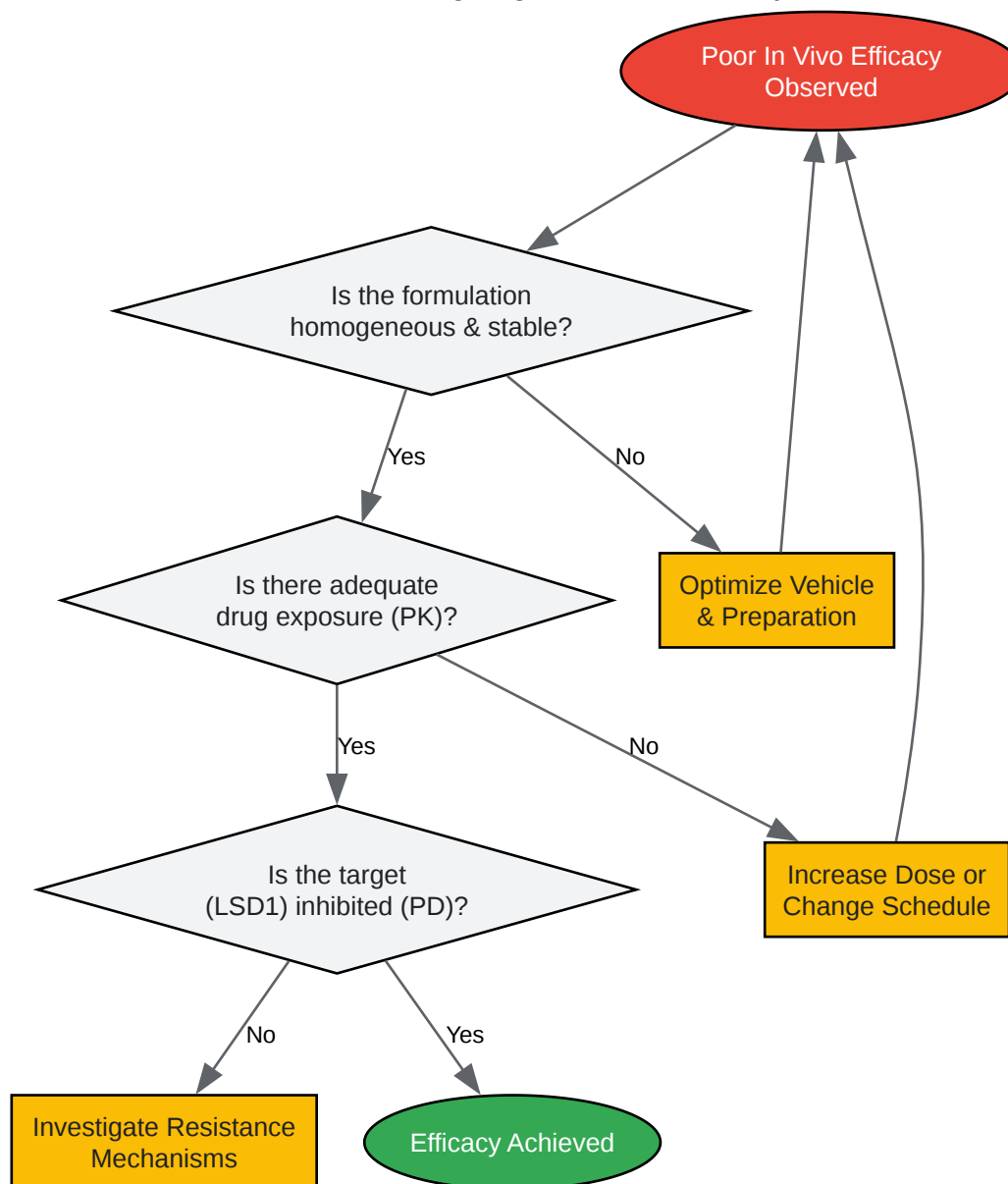

[Click to download full resolution via product page](#)

Caption: A logical approach to troubleshooting poor in vivo efficacy.

**Need Custom Synthesis?**

BenchChem offers custom synthesis for rare earth carbides and specific isotopic labeling.

Email: [info@benchchem.com](mailto:info@benchchem.com) or [Request Quote Online](#).

## References

- 1. Considerations and Pitfalls in Selecting the Drug Vehicles for Evaluation of New Drug Candidates: Focus on in vivo Pharmacotoxicological Assays Based on the Rotarod Performance Test - PubMed [pubmed.ncbi.nlm.nih.gov]
- 2. benchchem.com [benchchem.com]
- 3. benchchem.com [benchchem.com]
- 4. researchgate.net [researchgate.net]
- 5. Comprehensive in Vitro Characterization of the LSD1 Small Molecule Inhibitor Class in Oncology - PMC [pmc.ncbi.nlm.nih.gov]
- 6. benchchem.com [benchchem.com]
- 7. benchchem.com [benchchem.com]
- 8. Lysine-specific demethylase 1A restricts ex vivo propagation of human HSCs and is a target of UM171 - PMC [pmc.ncbi.nlm.nih.gov]
- 9. Inhibition of Lysine-Specific Demethylase-1 (LSD1/KDM1A) Promotes the Adipogenic Differentiation of hESCs Through H3K4 Methylation - PMC [pmc.ncbi.nlm.nih.gov]
- 10. Silencing Lysine-Specific Histone Demethylase 1 (LSD1) Causes Increased HP1-Positive Chromatin, Stimulation of DNA Repair Processes, and Dysregulation of Proliferation by Chk1 Phosphorylation in Human Endothelial Cells - PMC [pmc.ncbi.nlm.nih.gov]
- 11. LSD1 inhibitors for cancer treatment: Focus on multi-target agents and compounds in clinical trials - PMC [pmc.ncbi.nlm.nih.gov]
- 12. LSD1 negatively regulates autophagy through the mTOR signaling pathway in ovarian cancer cells - PubMed [pubmed.ncbi.nlm.nih.gov]
- 13. LSD1 regulates Notch and PI3K/Akt/mTOR pathways through binding the promoter regions of Notch target genes in esophageal squamous cell carcinoma - PMC [pmc.ncbi.nlm.nih.gov]
- 14. LSD1 Activates PI3K/AKT Signaling Through Regulating p85 Expression in Prostate Cancer Cells - PMC [pmc.ncbi.nlm.nih.gov]
- To cite this document: BenchChem. [Technical Support Center: Lsd1-IN-34 In Vivo Delivery]. BenchChem, [2026]. [Online PDF]. Available at: [https://www.benchchem.com/product/b15620275/docs#technical-support-center-ld1-in-34-in-vivo-delivery]

**Disclaimer & Data Validity:**

The information provided in this document is for Research Use Only (RUO) and is strictly not intended for diagnostic or therapeutic procedures. While BenchChem strives to provide accurate protocols, we make no warranties, express or implied, regarding the fitness of this product for every specific experimental setup.

**Technical Support:** The protocols provided are for reference purposes. Unsure if this reagent suits your experiment?

**Need Industrial/Bulk Grade?** [Request Custom Synthesis Quote](#)

## BenchChem

Our mission is to be the trusted global source of essential and advanced chemicals, empowering scientists and researchers to drive progress in science and industry.

### Contact

Address: 3281 E Guasti Rd  
Ontario, CA 91761, United States  
Phone: (601) 213-4426  
Email: [info@benchchem.com](mailto:info@benchchem.com)

[Contact our Ph.D. Support Team for a compatibility check](#)